

NPN Bipolar RF Transistor

- High transducer gain of typ. 24 dB @ 13 mA, 1.9 GHz
- Low minimum noise figure of typ. 0.5 dB @ 1.9 GHz
- Pb-free (RoHS compliant) package
- For a wide range of non-automotive applications
 - 2nd and 3rd LNA stage and mixer stage in LNB
 - 5.8 GHz analog/digital cordless phone

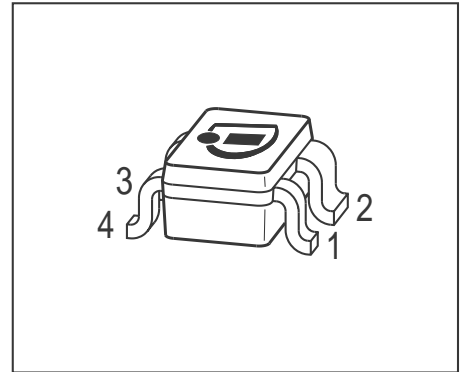

ESD (Electrostatic discharge) sensitive device, observe handling precaution!

Type	Marking	Pin Configuration						Package
BF886	RZs	1=B	2=E	3=C	4=E	-	-	SOT343

Maximum Ratings at $T_A = 25\text{ °C}$, unless otherwise specified

Parameter	Symbol	Value	Unit
Collector-emitter voltage	V_{CEO}	4.0	V
$T_A = 25\text{ °C}$		4.0	
$T_A = -55\text{ °C}$		3.5	
Collector-emitter voltage	V_{CES}	13	
Collector-base voltage	V_{CBO}	13	
Emitter-base voltage	V_{EBO}	1.2	
Collector current	I_C	25	mA
Base current	I_B	2	
Total power dissipation ¹⁾	P_{tot}	100	mW
$T_S \leq 108\text{ °C}$			
Junction temperature	T_J	150	°C
Storage temperature	T_{Stg}	-55 ... 150	

¹⁾ T_S is measured on the emitter lead at the soldering point to the pcb

Thermal Resistance

Parameter	Symbol	Value	Unit
Junction - soldering point ¹⁾	R_{thJS}	≤ 420	K/W

Electrical Characteristics at $T_A = 25^\circ\text{C}$, unless otherwise specified

Parameter	Symbol	Values			Unit
		min.	typ.	max.	
DC Characteristics					
Collector-emitter breakdown voltage $I_C = 1 \text{ mA}, I_B = 0$	$V_{(BR)CEO}$	4	4.7	-	V
Collector-emitter cutoff current $V_{CE} = 2 \text{ V}, V_{BE} = 0$	I_{CES}	-	1	-	nA
Collector-base cutoff current $V_{CB} = 2 \text{ V}, I_E = 0$	I_{CBO}	-	1	-	
Emitter-base cutoff current $V_{EB} = 0.5 \text{ V}, I_C = 0$	I_{EBO}	-	10	-	
DC current gain $I_C = 13 \text{ V}, V_{CE} = 3 \text{ V}$, pulse measured	h_{FE}	-	250	-	-

¹For calculation of R_{thJA} please refer to Application Note Thermal Resistance

Electrical Characteristics at $T_A = 25^\circ\text{C}$, unless otherwise specified

Parameter	Symbol	Values			Unit
		min.	typ.	max.	
AC Characteristics (verified by random sampling)					
Transition frequency $I_C = 13 \text{ mA}$, $V_{CE} = 3 \text{ V}$, $f = 1 \text{ GHz}$	f_T	-	45	-	GHz
Collector-base capacitance $V_{CB} = 3 \text{ V}$, $f = 1 \text{ MHz}$, $V_{BE} = 0$, emitter grounded	C_{cb}	-	0.06	-	pF
Collector emitter capacitance $V_{CE} = 3 \text{ V}$, $f = 1 \text{ MHz}$, $V_{BE} = 0$, base grounded	C_{ce}	-	0.35	-	
Emitter-base capacitance $V_{EB} = 0.5 \text{ V}$, $f = 1 \text{ MHz}$, $V_{CB} = 0$, collector grounded	C_{eb}	-	0.35	-	
Noise figure $I_C = 5 \text{ mA}$, $V_{CE} = 3 \text{ V}$, $f = 1.9 \text{ GHz}$, $Z_S = Z_{Sopt}$ $I_C = 5 \text{ mA}$, $V_{CE} = 3 \text{ V}$, $f = 5.5 \text{ GHz}$, $Z_S = Z_{Sopt}$	F	-	0.5 0.7	-	dB
Power gain $I_C = 13 \text{ mA}$, $V_{CE} = 3 \text{ V}$, $Z_S = Z_{Sopt}$, $Z_L = Z_{Lopt}$, $f = 1.9 \text{ GHz}$	G_{ms}	-	26	-	dB
Power gain, maximum available ¹⁾ $I_C = 13 \text{ mA}$, $V_{CE} = 3 \text{ V}$, $Z_S = Z_{Sopt}$, $Z_L = Z_{Lopt}$, $f = 5.5 \text{ GHz}$	G_{ma}	-	19	-	dB
Transducer gain $I_C = 13 \text{ mA}$, $V_{CE} = 3 \text{ V}$, $Z_S = Z_L = 50 \Omega$, $f = 1.9 \text{ GHz}$ $f = 5.5 \text{ GHz}$	$ S_{21e} ^2$	-	24 16	-	dB
Third order intercept point at output ²⁾ $V_{CE} = 3 \text{ V}$, $I_C = 13 \text{ mA}$, $f = 5.5 \text{ GHz}$, $Z_S = Z_L = 50 \Omega$	IP_3	-	23	-	dBm
1dB Compression point $I_C = 13 \text{ mA}$, $V_{CE} = 3 \text{ V}$, $Z_S = Z_L = 50 \Omega$, $f = 5.5 \text{ GHz}$	P_{-1dB}	-	8	-	

$$^1G_{ma} = |S_{21e} / S_{12e}| (k - (k^2 - 1)^{1/2})$$

²⁾IP3 value depends on termination of all intermodulation frequency components.
Termination used for this measurement is 50Ω from 0.1 MHz to 6 GHz

Package Outline

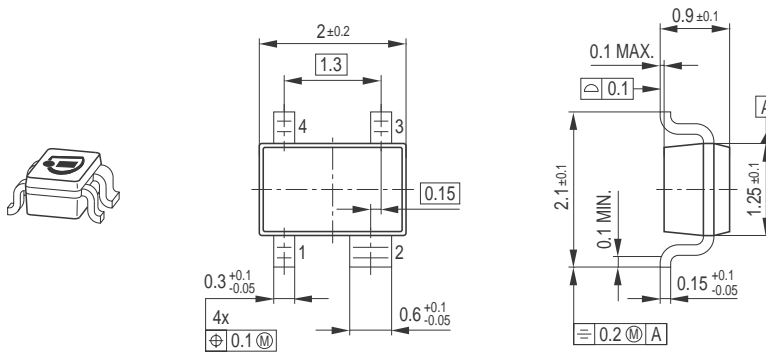

Foot Print

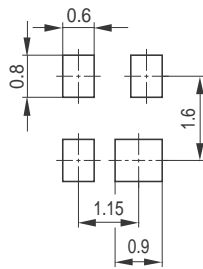

Marking Layout (Example)

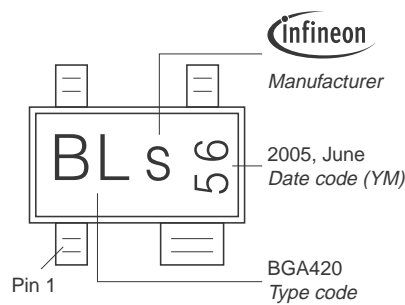

Standard Packing

Reel \varnothing 180 mm = 3.000 Pieces/Reel
 Reel \varnothing 330 mm = 10.000 Pieces/Reel

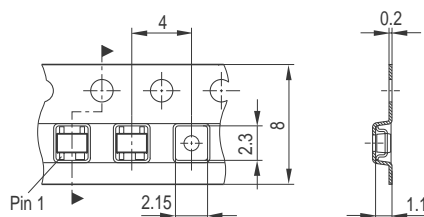

Edition 2009-11-16

**Published by
Infineon Technologies AG
81726 Munich, Germany**

**© 2009 Infineon Technologies AG
All Rights Reserved.**

Legal Disclaimer

The information given in this document shall in no event be regarded as a guarantee of conditions or characteristics. With respect to any examples or hints given herein, any typical values stated herein and/or any information regarding the application of the device, Infineon Technologies hereby disclaims any and all warranties and liabilities of any kind, including without limitation, warranties of non-infringement of intellectual property rights of any third party.

Information

For further information on technology, delivery terms and conditions and prices, please contact the nearest Infineon Technologies Office (www.infineon.com).

Warnings

Due to technical requirements, components may contain dangerous substances. For information on the types in question, please contact the nearest Infineon Technologies Office.

Infineon Technologies components may be used in life-support devices or systems only with the express written approval of Infineon Technologies, if a failure of such components can reasonably be expected to cause the failure of that life-support device or system or to affect the safety or effectiveness of that device or system. Life support devices or systems are intended to be implanted in the human body or to support and/or maintain and sustain and/or protect human life. If they fail, it is reasonable to assume that the health of the user or other persons may be endangered.