

EiceDRIVER™ 1EDNx550

Single-channel high-side and low-side gate driver with high-CMR TDI inputs

Description

EiceDRIVER™1EDNx550 is part of the TDI family of single-channel high-side and low-side gate driver ICs. The TDI family has a fully differential input circuitry. The truly differential inputs (TDI) provide excellent common-mode robustness (CMR) and eliminates the risk of false triggering. The small package footprints enable versatile layout in both low-side and high-side driving.

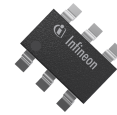

SOT23-6



TSNP-6

Product features

- Very large common-mode input voltage range (CMR static) up to ± 200 V, configurable with common mode resistors
- Separate low impedance source (4 A) and sink (8 A) outputs
- 45 ns propagation delay (-7/+10 ns accuracy)
- Four UVLO options: 4 V, 8 V, 12 V and 15 V
- SOT23-6 or TSNP-6 small packages
- Fully qualified according to JEDEC for industrial grade applications

Topologies

- 4-pin Kelvin-source MOSFETs in boost PFCs
- Low-side driving with high PCB parasitic inductance
- High-side driving in switched tank converters
- High and low-side driving in half and full-bridges
- Driving SJ and SiC MOSFETs, GaN HEMTs
- Switches requiring negative drive voltage

Applications

- Server, telecom and industrial SMPS
- DC-DC converters and bricks
- Power tools, motor control

Table 1 Product portfolio

Part number	Package	UVLO ON/OFF	Output current	Max. CMR static ¹⁾	Max. CMR dynamic ¹⁾
1EDN7550U	PG-TSNP-6	4.2 V / 3.9 V	-8 A / +4 A	± 200 V	± 400 V
1EDN7550B	PG-SOT23-6	8.0 V / 7.0 V			
1EDN8550B		12.2 V / 11.5 V			
1EDN6550B		14.9 V / 14.4 V			
1EDN9550B					

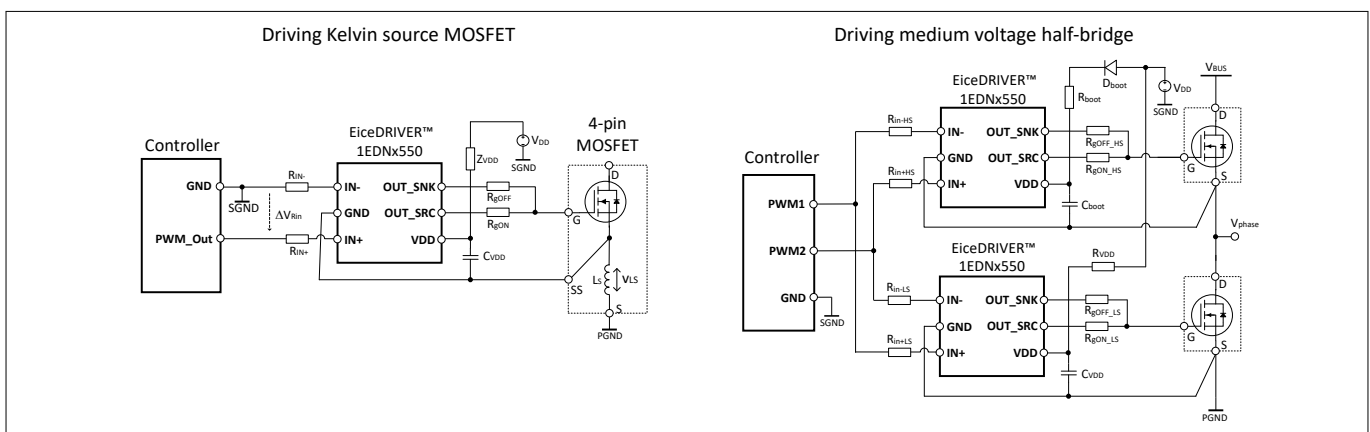

Figure 1 EiceDRIVER™ 1EDNx550 driving Kelvin-source MOSFET and half-bridge power stages

¹ CMR static and dynamic for the application depends on input resistors. Please see [Chapter 6.1](#)

Table of contents

	Description	1
	Table of contents	2
1	Pin configuration and description	3
2	Block diagram	4
3	Functional description	5
3.1	Truly differential input (TDI)	5
3.1.1	Common-mode input range	6
3.2	Driver outputs	6
3.3	Supply voltage and undervoltage lockout (UVLO)	7
4	Electrical characteristics and parameters	8
4.1	Absolute maximum ratings	8
4.2	Thermal characteristics	9
4.3	Operating range	10
4.4	Electrical characteristics	10
4.5	Timing diagram	13
5	Typical characteristics	14
6	Application and implementation	17
6.1	Input resistor dimensioning	17
6.2	Half-bridge driving	17
6.3	Switches with Kelvin-source connection (4-pin packages)	18
6.4	Applications with significant parasitic PCB-inductances	19
6.5	Switches with bipolar gate drive	20
7	Layout guidelines	21
8	Package information	23
8.1	Device numbers and markings	23
8.2	PG-SOT23-6 package	23
8.3	PG-TSNP-6 package	26
9	List of abbreviations	28
	References	29
	Revision history	30
	Disclaimer	32

1 Pin configuration and description

1 Pin configuration and description

The pin configuration for both SOT23-6 and TSNP-6 package is illustrated in Figure 2 and a description is given in Table 2. For functional details, please read Chapter 3.

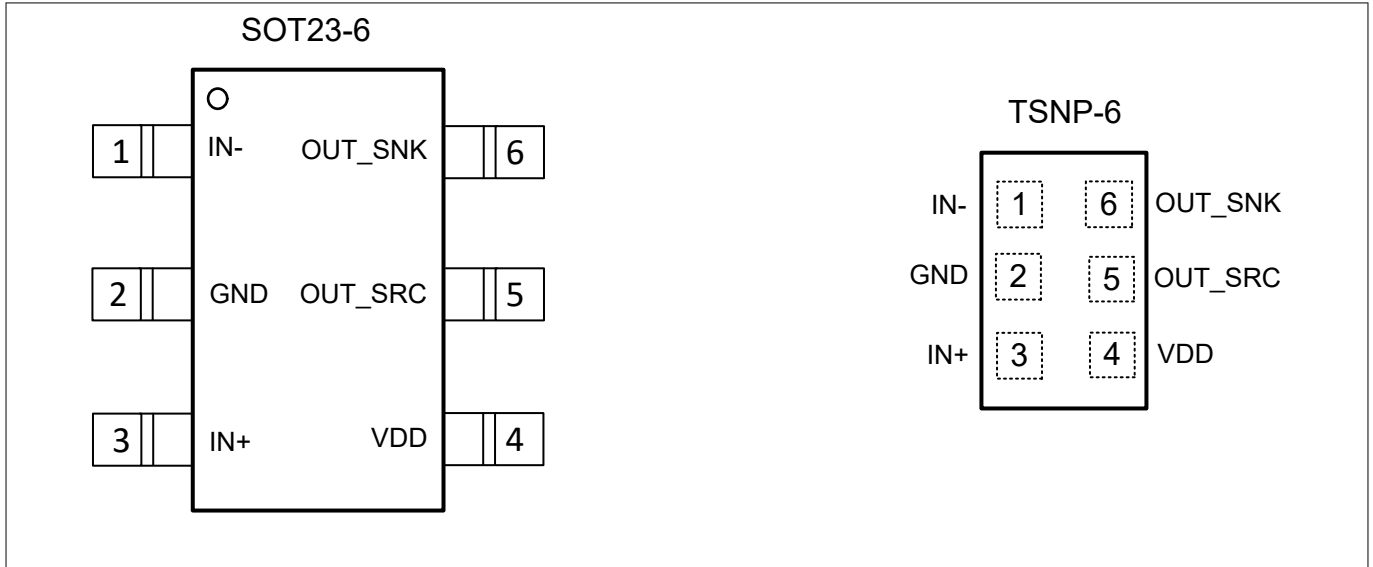

Figure 2 Pin configuration SOT23-6 and TSNP-6 6-pin packages (top view)

Table 2 Pin description

Pin number	Pin name	Description
1	IN-	Negative input connected to controller PWM or ground via input resistor (see Chapter 6)
2	GND	Ground negative gate drive voltage ("off" state voltage)
3	IN+	Positive input connected to controller PWM or ground via input resistor (see Chapter 6)
4	VDD	Supply voltage positive gate drive voltage ("on" state voltage)
5	OUT_SRC	Driver output source low-impedance switch to VDD (4 A/0.85 Ω)
6	OUT_SNK	Driver output sink low-impedance switch to GND (8 A/0.35 Ω)

2 Block diagram

2 Block diagram

A simplified functional block diagram of EiceDRIVER™ 1EDNx550 is given in [Figure 3](#).

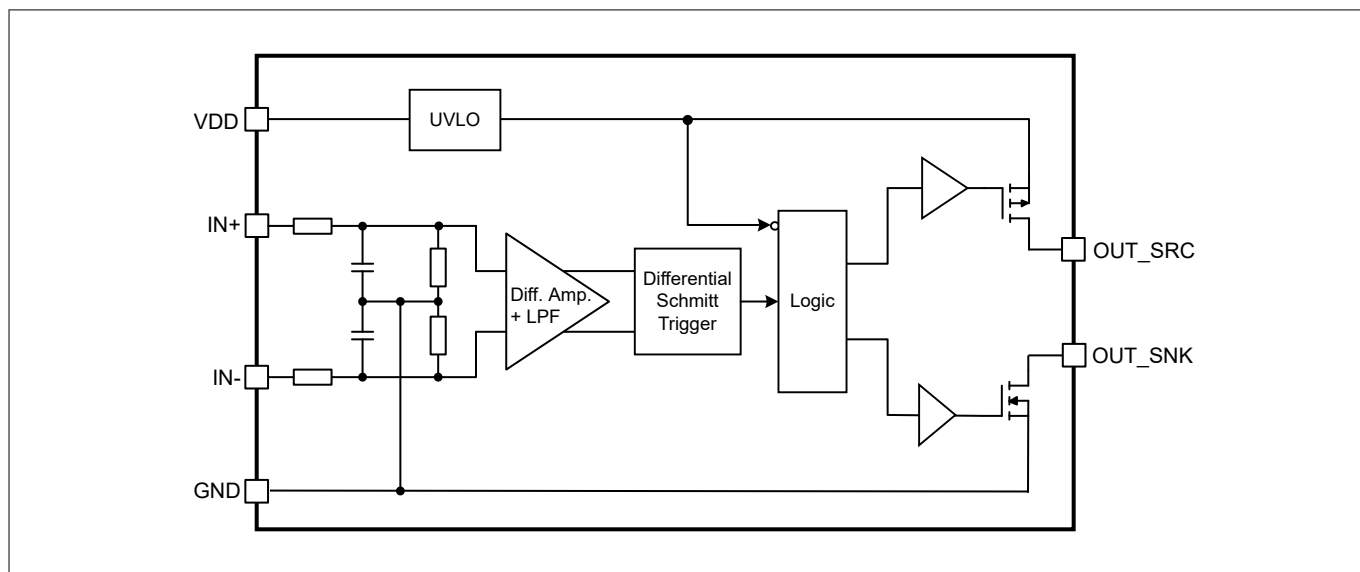

Figure 3 Simplified block diagram of EiceDRIVER™ 1EDNx550

3 Functional description

3 Functional description

EiceDRIVER™ 1EDNx550 is a family of high-side and low-side non-isolated gate drivers whose application ranges into fields usually reserved for isolated and level shifter drivers, resulting in significant cost benefits. This is made possible by the unique truly differential input (TDI) stage concept. The TDI input stage allows controlling the driver even if a common-mode voltage is present on the input differential pair. Common-mode voltages up to ±200 V DC and ±400 V AC peak between ground reference (GND) and driver inputs (IN-, IN+) are possible.

EiceDRIVER™ 1EDNx550 is suited for any application with unwanted voltage shifts between driver and system ground and in high-side driving within the allowed static common-mode range (±200 V max., see Chapter 6.1). Switches requiring a bipolar driving voltage can be operated easily as well, taking advantage of the common mode voltage handling capability of the TDI.

3.1 Truly differential input (TDI)

Figure 4 depicts the signal path from the controller’s PWM output to the logic gate driver signal input as implemented in 1EDNx550.

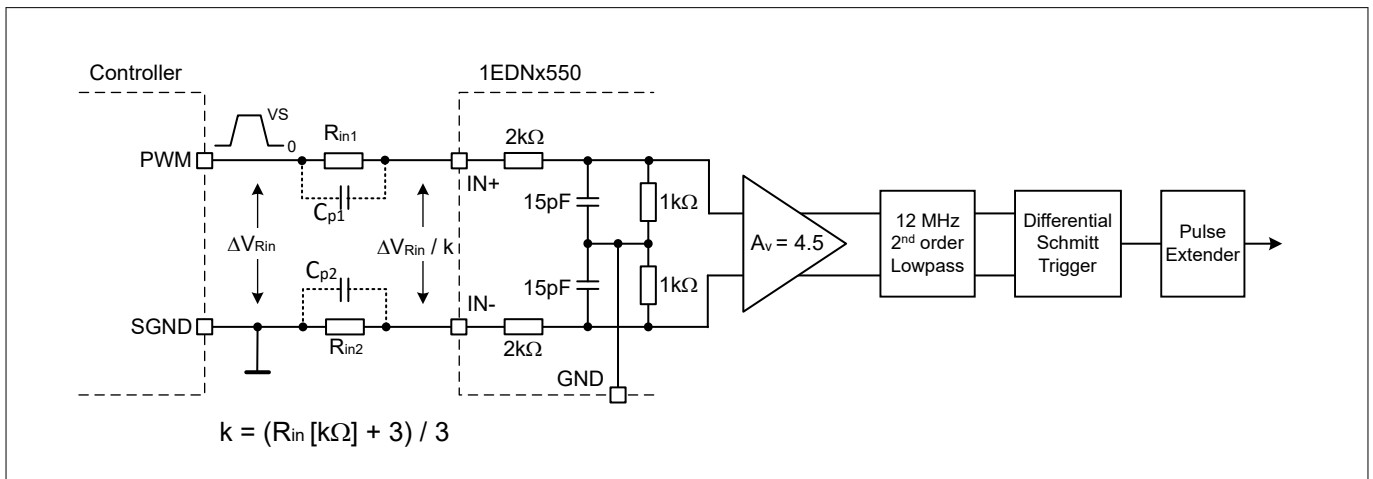

Figure 4 Functional principle of the EiceDRIVER™ 1EDNx550 with truly differential inputs (TDI)

The two input resistors R_{in1} and R_{in2} are mandatory for correct operation of EiceDRIVER™ 1EDNx550 since this gate driver IC cannot be used as a standard low-side driver with IN- directly connected to GND pin. The PWM pin of the controller shall be connected to IN+ pin of EiceDRIVER™ 1EDNx550 through resistor R_{in1} , while the SGND pin of the controller (or PWM in case of half-bridge configurations) shall be connected to IN- pin through resistor R_{in2} . The two resistors R_{in1} and R_{in2} , together with the 2 kΩ and 1 kΩ resistors inside the driver, allow to implement a high common-mode rejection ratio (CMRR) differential amplifier that functionally decouples the controller outputs from ground of the gate driver.

R_{in1} and R_{in2} input resistors shall be chosen as a function of the maximum ΔV_{Rin} and the required static common-mode voltage between the driver ground and the controller ground, according to Table 16.

As an example, for maximum $\Delta V_{Rin} = 3.3$ V, R_{in1} and R_{in2} should be 33 kΩ, resulting in a static divider ratio of $k = 12$ at the driver inputs, as per the following voltage divider formula:

$$k = (R_{in} [k\Omega] + 3) / 3 \tag{1}$$

For ΔV_{Rin} other than 3.3 V, R_{in1} and R_{in2} must fulfill the relation:

$$R_{in1} = R_{in2} = (10.9 * V_S - 3) [k\Omega] \tag{2}$$

3 Functional description

where V_S is the high voltage level of the PWM signal, usually equal to the controller supply voltage. A lookup table is also available in [Table 16](#) as a guide for selecting the value, form factor and tolerance of resistors R_{in1} and R_{in2} .

The input signal is then amplified by a factor of 4.5 from the high-CMRR amplifier and filtered by a 2nd order low-pass filter. Considering also the passive differential RC filter in front of the high-CMRR amplifier, the overall input signal experiences 3rd order filtering with a corner frequency at 12 MHz. The suppression of high frequencies is important to dampen ringing at 100 MHz and above in fast-switching power systems and also makes the driver robust against any mismatch of C_{p1} and C_{p2} input parasitic capacitance (50 to 100 fF range). The filtered signal is then applied to the differential Schmitt-Trigger that feeds a pulse extender. The pulse extender avoids the transfer of PWM signals shorter than 25 ns to the output stage, improving noise immunity. Overall typical input-to-output propagation delay is 45 ns. A propagation delay accuracy of +10/-7 ns is achieved.

3.1.1 Common-mode input range

Due to the passive low-pass filtering at the input side, the CMR (common-mode robustness, i.e. the maximum allowed voltage difference between controller outputs PWM/SGND and driver reference GND) can be split into CMR static and CMR dynamic parameters, depending on the common-mode voltage frequency content. Provided a certain input resistor and controller voltage configuration, the CMR static describes the capability of the driver to withstand DC voltages, while the CMR dynamic describes the capability of the driver to withstand AC voltages due to overshoots or ringing.

The CMR capabilities strongly depend on input resistors R_{in1} and R_{in2} . The value and accuracy of resistors must allow to meet the maximum device voltage ratings at IN+/IN- pins while their form factor shall be chosen to meet power dissipation and creepage requirements.

In more detail, CMR static is limited by the operating voltage at the input pins IN+/IN- (+6 V/-7 V) to allow input stage to work in linear mode. CMR dynamic is limited by the absolute maximum ratings (+10 V/-10 V) on the same pins. As an example, if 33 k Ω , 0.1% tolerance, 0603 form factor resistors and 3.3 V controller supply voltage are used, this translates into a static CMR range of +72/-84 V. Under the same conditions, the maximum input voltage ratings at pins IN+/IN- of ± 10 V results in a dynamic CMR range of ± 150 V.

In case of 127 k Ω , 0.1% tolerance, 1206 form factor resistors and 12 V maximum PWM voltage, the maximum CMR static is ± 200 V and the maximum CMR dynamic is ± 400 V.

In case of different PWM voltages and input resistor configurations, please refer the lookup table in [Chapter 6.1](#). The lookup table helps to select the proper resistor parameters (value, form factor, tolerance) depending on the needed CMR parameters and PWM voltage, or to check the maximum allowed CMR depending on the PWM output voltage and input resistors.

Please be aware that a perfectly symmetric layout of the input signal path is mandatory to reach the full CMR ranges mentioned above. Any parasitic imbalance in the signal path converts a common-mode signal into a differential signal, resulting in reduced CMR performances. Layout recommendations can be found in [Chapter 7](#).

3.2 Driver outputs

The rail-to-rail driver output stage made with complementary MOS transistors can provide a typical 4 A sourcing and 8 A sinking current.

The low on-resistance associated with high driving current is particularly beneficial for fast switching of low R_{dsON} MOSFETs. With a R_{ON} of 0.85 Ω for the sourcing pMOS and 0.35 Ω for the sinking nMOS transistor, the driver can be considered to behave as an ideal switch.

The p-channel sourcing transistor allows real rail-to-rail behavior without suffering from the voltage drop that is common for n-channel output stages.

In case of unconnected inputs, the driver output is actively clamped to the “low” level (GND).

3 Functional description

3.3 Supply voltage and undervoltage lockout (UVLO)

The undervoltage lockout function ensures that the output can be switched only if the supply voltage V_{DD} exceeds the UVLO threshold voltage. Thus, this feature can ensure that the power switch is not operated with low driving voltage, achieving a complete and fast transition to the "on" state and avoiding excessive power dissipation.

Table 3 Logic table

ΔV_{Rin}	UVLO	OUT_SRC	OUT_SNK
X	active ²⁾	high impedance	L
L ³⁾	inactive ⁴⁾	high impedance	L
H ⁵⁾	inactive ⁴⁾	H	high impedance

EiceDRIVER™ 1EDNx550 is available in two different packages; the SOT23-6 version offers four UVLO threshold levels to support switches with a broad range of gate source voltages:

- 1EDN7550 with a typical UVLO threshold of 4.2 V (0.3 V hysteresis)
- 1EDN8550 with a typical UVLO threshold of 8 V (1 V hysteresis)
- 1EDN6550 with a typical UVLO threshold of 12.2 V (0.7 V hysteresis)
- 1EDN9550 with a typical UVLO threshold of 14.9 V (0.5 V hysteresis)

In addition, the maximum V_{DD} of 20 V makes this driver family well-suited for a broad variety of power switch types such as OptiMOS™, CoolMOS™, CoolGaN™ and CoolSiC™.

²⁾ $V_{DD} < UVLO_{off}$

³⁾ $\Delta V_{Rin} < \Delta V_{RinL}$

⁴⁾ $V_{DD} > UVLO_{on}$

⁵⁾ $\Delta V_{Rin} > \Delta V_{RinH}$

4 Electrical characteristics and parameters

4 Electrical characteristics and parameters

Note: The absolute maximum ratings are listed in Table 4. Stresses beyond these values may cause permanent damage to the device. Exposure to absolute maximum rating conditions for extended periods may affect device reliability.

4.1 Absolute maximum ratings

Table 4 Absolute maximum ratings

Parameter	Symbol	Values			Unit	Note or Test Condition
		Min.	Typ.	Max.		
Supply voltage	V_{DD}	-0.3	–	22	V	Voltage between VDD to GND
Voltage at pins IN+ and IN-	V_{IN}	-10	–	10	V	–
Voltage at pin OUT_SRC	V_{OUT_SRC}	-24	–	0.3	V	OUT = low; referred to VDD pin, DC
		-24	–	2	V	OUT = low; referred to VDD pin < 200 ns
Voltage at pin OUT_SNK	V_{OUT_SNK}	-0.3	–	24	V	OUT = high; referred to GND pin, DC
		-2	–	24	V	OUT = high; referred to GND pin < 200 ns
Peak reverse current at OUT_SNK	I_{SNK_rev}	-5	–	–	A	< 500 ns
Peak reverse current at OUT_SRC	I_{SRC_rev}	–	–	5	A	< 500 ns
Junction temperature	T_J	-40	–	150	°C	–
Storage temperature	T_S	-55	–	150	°C	–
ESD capability	V_{ESD_HBM}	–	–	2	kV	Human Body Model (HBM) ⁶
ESD capability	V_{ESD_CDM}	–	–	1	kV	Charged Device Model (CDM) ⁷

⁶ According to ANSI/ESDA/JEDEC JS-001 (discharging 100 pF capacitor through 1.5 kΩ resistor)

⁷ According to ANSI/ESDA/JEDEC JS-002

4 Electrical characteristics and parameters

4.2 Thermal characteristics

Table 5 Thermal characteristics SOT23-6 package

Parameter	Symbol	Values			Unit	Note or Test Condition
		Min.	Typ.	Max.		
Thermal resistance junction-ambient ⁸⁾	R_{thJA25}	–	165.1	–	K/W	–
Thermal resistance junction-case (top) ⁹⁾	R_{thJC25}	–	79.9	–	K/W	–
Thermal resistance junction-board ¹⁰⁾	R_{thJB25}	–	65.2	–	K/W	–
Characterization parameter junction-case (top) ¹¹⁾	Ψ_{thJC25}	–	14	–	K/W	–
Characterization parameter junction-board ¹²⁾	Ψ_{thJB25}	–	51	–	K/W	–

Table 6 Thermal characteristics TSNP-6 package

Parameter	Symbol	Values			Unit	Note or Test Condition
		Min.	Typ.	Max.		
Thermal resistance junction-ambient ⁸⁾	R_{thJA25}	–	140	–	K/W	–
Thermal resistance junction-case (top) ⁹⁾	R_{thJC25}	–	80	–	K/W	–
Thermal resistance junction-board ¹⁰⁾	R_{thJB25}	–	56	–	K/W	–
Characterization parameter junction-case (top) ¹¹⁾	Ψ_{thJC25}	–	1.6	–	K/W	–
Characterization parameter junction-board ¹²⁾	Ψ_{thJB25}	–	35	–	K/W	–

⁸⁾ Obtained in a simulation on a JEDEC-standard, high-K board, as specified in JESD51-7, in an environment described in JESD51-2a

⁹⁾ Obtained by simulating a cold plate test on the package top. No specific JEDEC standard test exists, but a close description can be found in the ANSI SEMI standard G30-88

¹⁰⁾ Obtained by simulation in an environment with a ring cold plate fixture to control the PCB temperature, as described in JESD51-8

¹¹⁾ Estimates the junction temperature of a device in a real system and is extracted from the simulation data for obtaining R_{th} , using a procedure described in JESD51-2a (sections 6 and 7)

¹²⁾ Estimates the junction temperature of a device in a real system and is extracted from the simulation data for obtaining R_{th} , using a procedure described in JESD51-2a (sections 6 and 7)

4 Electrical characteristics and parameters

4.3 Operating range

Table 7 Operating range

Parameter	Symbol	Values			Unit	Note or Test Condition
		Min.	Typ.	Max.		
Supply voltage	V_{DD}	4.5	–	20	V	Min defined by UVLO
Voltage at pins IN+ and IN-	V_{IN}	-7	–	6	V	–
Junction temperature	T_J	-40	–	150	°C	¹³⁾

4.4 Electrical characteristics

Unless otherwise noted, min./max. values of characteristics are the lower and upper limits, respectively. They are valid within the full operating range. The supply voltage is $V_{DD} = 12\text{ V}$ unless otherwise specified. Typical values are given at $T_J = 25^\circ\text{C}$

Table 8 Power supply

Parameter	Symbol	Values			Unit	Note or Test Condition
		Min.	Typ.	Max.		
V_{DD} quiescent current	I_{VDDh}	–	1.1	–	mA	OUT = high $V_{DD} = 12\text{ V}$
V_{DD} quiescent current	I_{VDDh}	–	1.3	–	mA	OUT = high $V_{DD} = 18\text{ V}$ ¹⁴⁾
V_{DD} quiescent current	I_{VDDl}	–	0.9	–	mA	OUT = low $V_{DD} = 12\text{ V}$
V_{DD} quiescent current	I_{VDDl}	–	1.0	–	mA	OUT = low $V_{DD} = 18\text{ V}$ ¹⁴⁾

Table 9 Undervoltage Lockout 1EDN7550x (Logic level MOSFET)

Parameter	Symbol	Values			Unit	Note or Test Condition
		Min.	Typ.	Max.		
Undervoltage Lockout (UVLO) turn on threshold	$UVLO_{on}$	3.9	4.2	4.5	V	–
Undervoltage Lockout (UVLO) turn off threshold	$UVLO_{off}$	3.6	3.9	–	V	–
UVLO threshold hysteresis	$UVLO_{hys}$	0.25	0.3	0.35	V	–

¹³⁾ Continuous operation above 125°C may reduce life time

¹⁴⁾ Parameter verified by design/characterization, not 100% tested in production

4 Electrical characteristics and parameters

Table 10 Undervoltage Lockout 1EDN8550B (Standard MOSFET)

Parameter	Symbol	Values			Unit	Note or Test Condition
		Min.	Typ.	Max.		
Undervoltage Lockout (UVLO) turn on threshold	UVLO _{on}	7.4	8.0	8.6	V	–
Undervoltage Lockout (UVLO) turn off threshold	UVLO _{off}	6.6	7.0	–	V	–
UVLO threshold hysteresis	UVLO _{hys}	0.8	1.0	1.2	V	–

Table 11 Undervoltage Lockout 1EDN6550B (12 V UVLO option)

Parameter	Symbol	Values			Unit	Note or Test Condition
		Min.	Typ.	Max.		
Undervoltage Lockout (UVLO) turn on threshold	UVLO _{on}	11.7	12.2	12.7	V	–
Undervoltage Lockout (UVLO) turn off threshold	UVLO _{off}	11.0	11.5	–	V	–
UVLO threshold hysteresis	UVLO _{hys}	0.5	0.7	0.9	V	–

Table 12 Undervoltage Lockout 1EDN9550B (15 V UVLO option)

Parameter	Symbol	Values			Unit	Note or Test Condition
		Min.	Typ.	Max.		
Undervoltage Lockout (UVLO) turn on threshold	UVLO _{on}	14.4	14.9	15.4	V	–
Undervoltage Lockout (UVLO) turn off threshold	UVLO _{off}	13.9	14.4	–	V	–
UVLO threshold hysteresis	UVLO _{hys}	0.3	0.5	0.7	V	–

Table 13 Inputs IN+, IN-

Parameter	Symbol	Values			Unit	Note or Test Condition
		Min.	Typ.	Max.		
Differential input voltage threshold for transition LH (at input resistor)	ΔV_{RinH}	–	1.7	–	V	Independent of V_{DD} $R_{in1} = R_{in2} = 33 \text{ k}\Omega$ ¹⁵⁾
Differential input voltage threshold for transition HL (at input resistor)	ΔV_{RinL}	–	1.5	–	V	Independent of V_{DD} $R_{in1} = R_{in2} = 33 \text{ k}\Omega$ ¹⁵⁾
Total input resistance on each leg	R_{in1}, R_{in2}	–	36	–	k Ω	$R_{in1} = R_{in2} = 33 \text{ k}\Omega$ ¹⁵⁾

¹⁵⁾ see [Figure 1](#)

4 Electrical characteristics and parameters

Table 14 Static output characteristics

Parameter	Symbol	Values			Unit	Note or Test Condition
		Min.	Typ.	Max.		
High-level (sourcing) output resistance	R_{on_SRC}	–	0.85	–	Ω	$I_{SRC} = 50 \text{ mA}$
Sourcing output current	I_{SRC_pk}	–	4.0	–	A	¹⁶⁾ $V_{DD} = 12 \text{ V}$
Sourcing output current	I_{SRC_pk}	–	5.2	–	A	¹⁶⁾ $V_{DD} = 18 \text{ V}$
Low-level (sinking) output resistance	R_{on_SNK}	–	0.35	–	Ω	$I_{SNK} = 50 \text{ mA}$
Sinking output current	I_{SNK_pk}	–	-8.0	–	A	¹⁷⁾ $V_{DD} = 12 \text{ V}$
Sinking output current	I_{SNK_pk}	–	-9.4	–	A	¹⁷⁾ $V_{DD} = 18 \text{ V}$

Table 15 Dynamic characteristics

Parameter	Symbol	Values			Unit	Note or Test Condition
		Min.	Typ.	Max.		
Input-to-output propagation delay turn-on	t_{PDOn}	38	45	55	ns	$C_L = 200 \text{ pF}$
Input-to-output propagation delay turn-off	t_{PDOff}	38	45	55	ns	$C_L = 200 \text{ pF}$
Rise time	t_{rise}	–	6.5	15	ns	¹⁸⁾ $C_L = 1.8 \text{ nF}$
Fall time	t_{fall}	–	4.5	15	ns	¹⁸⁾ $C_L = 1.8 \text{ nF}$
Rise time	t_{rise}	–	1	5	ns	¹⁸⁾ $C_L = 200 \text{ pF}$
Fall Time	t_{fall}	–	1	5	ns	¹⁸⁾ $C_L = 200 \text{ pF}$
Minimum input pulse width that changes output state	t_{PW}	–	25	–	ns	¹⁸⁾ $C_L = 1.8 \text{ nF}$

For an illustration of the dynamic characteristics see [Figure 6](#) and [Figure 7](#)
[Figure 5](#) gives the circuit used for parameter testing

¹⁶⁾ Actively limited to approx. 5.2 A_{pk}; not subject to production test - verified by design/characterization

¹⁷⁾ Actively limited to approx. -10.4 A_{pk}; not subject to production test - verified by design/characterization

¹⁸⁾ Parameter verified by design, not 100% tested in production

4 Electrical characteristics and parameters

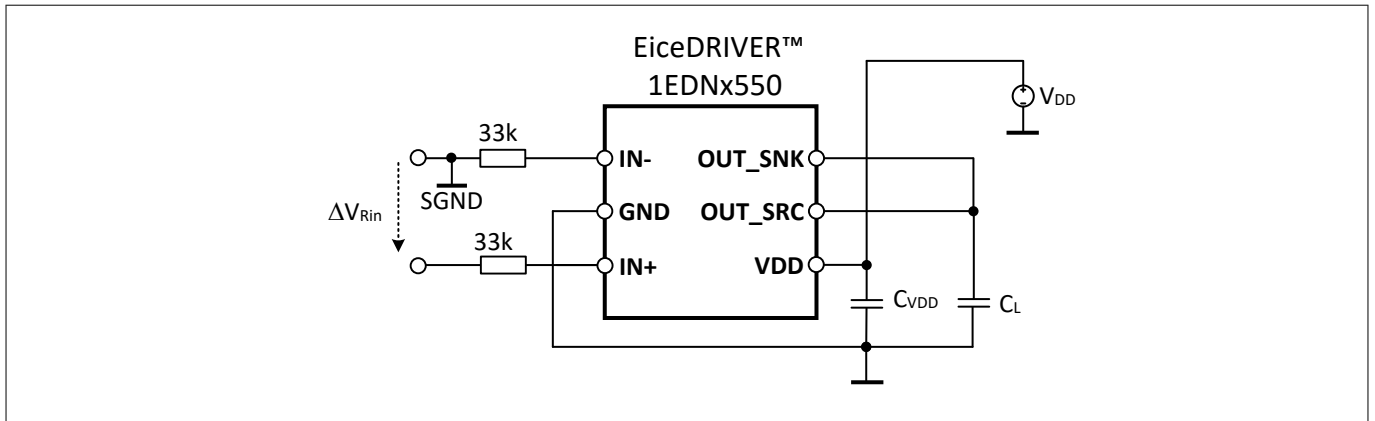

Figure 5 Test circuit

4.5 Timing diagram

Figure 6 depicts rise, fall and delay times as given in the Chapter 4.

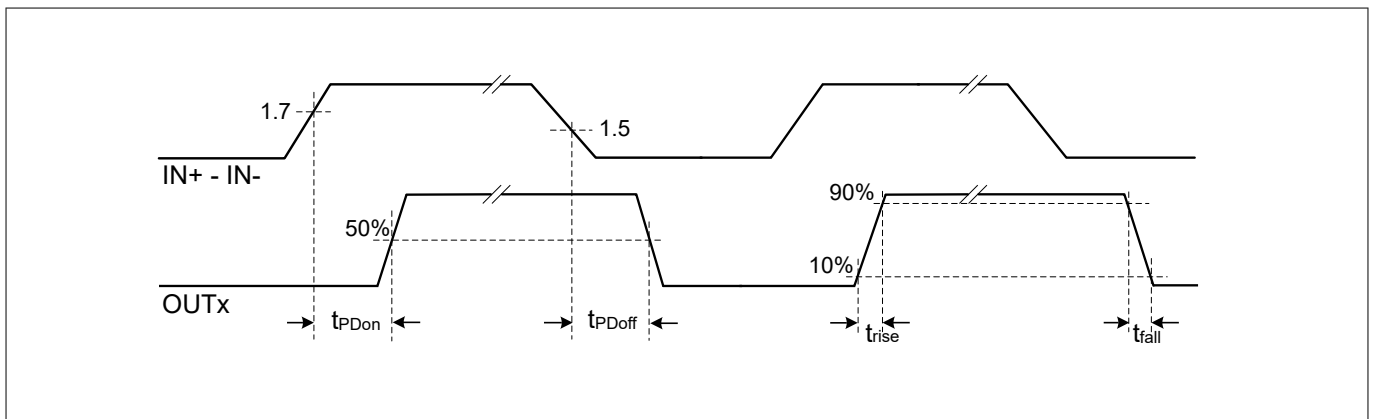

Figure 6 Propagation delay, rise and fall time

Figure 7 illustrates the undervoltage lockout function.

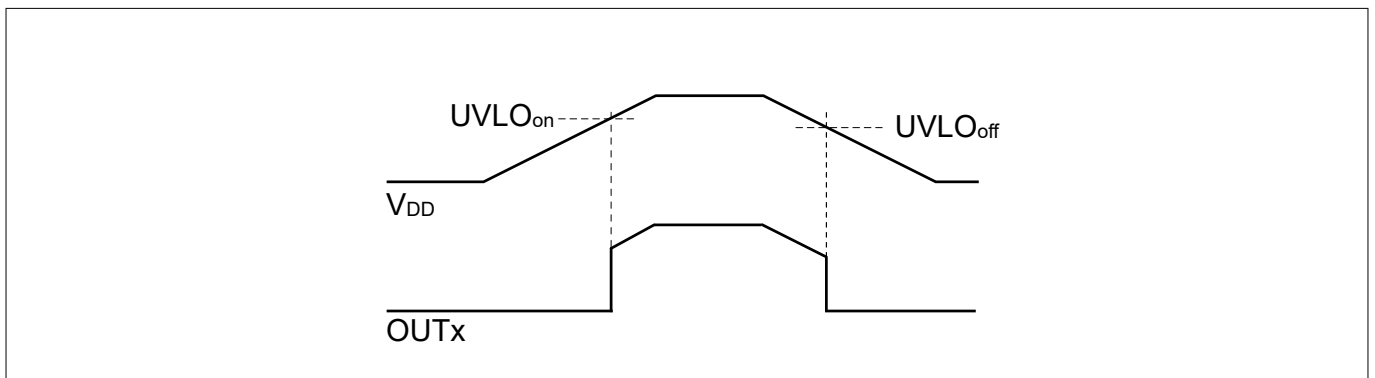
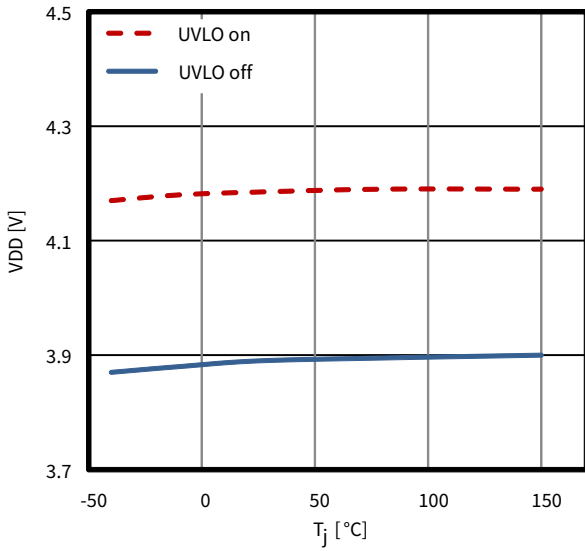

Figure 7 UVLO behavior (output state high)

5 Typical characteristics

5 Typical characteristics

1. Undervoltage lockout threshold (1EDN7550) vs temperature



2. Undervoltage lockout threshold (1EDN8550) vs temperature

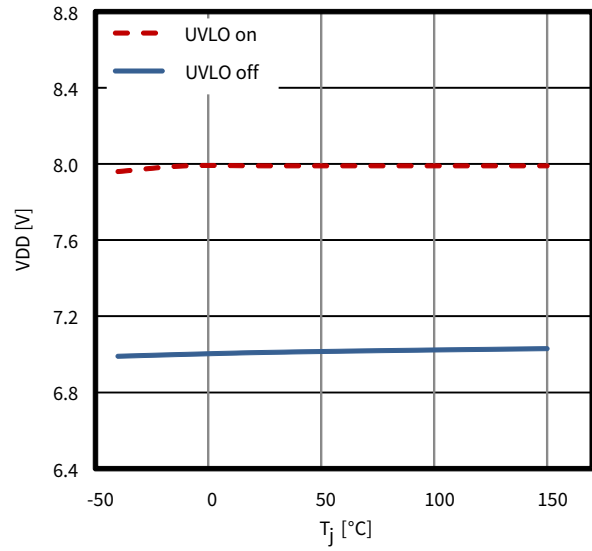

3. Undervoltage lockout threshold (1EDN6550) vs temperature

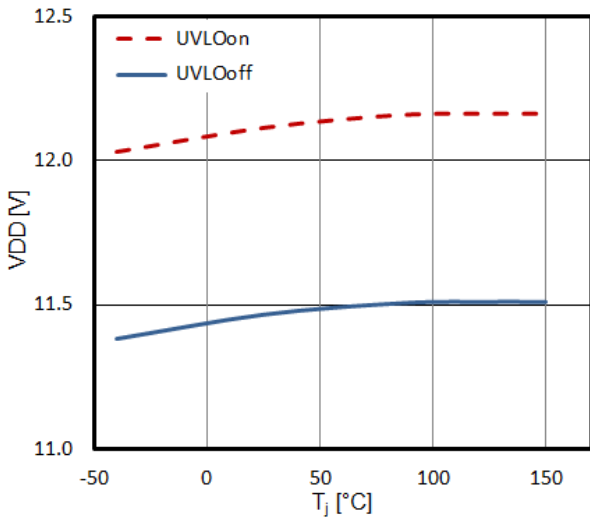

4. Undervoltage lockout threshold (1EDN9550) vs temperature

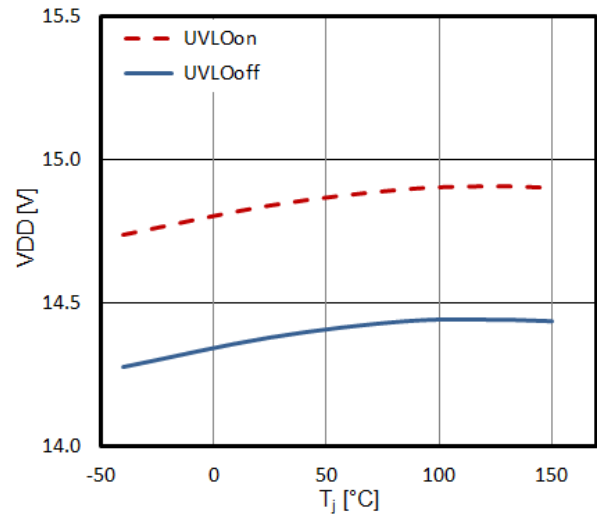

5 Typical characteristics

5. Differential input voltage threshold vs temperature

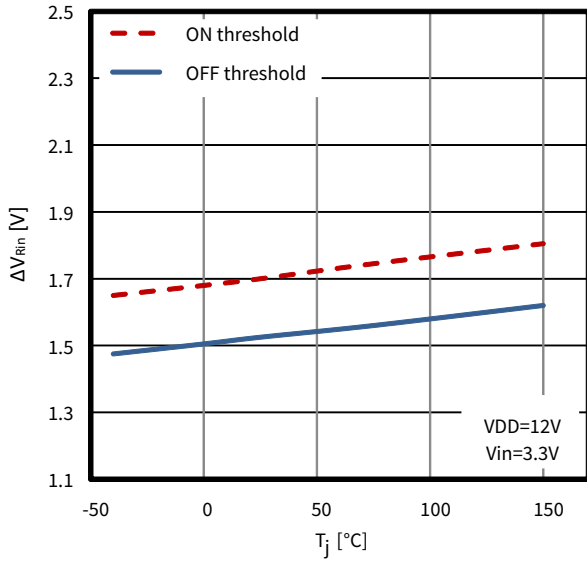

6. Typical quiescent current vs temperature

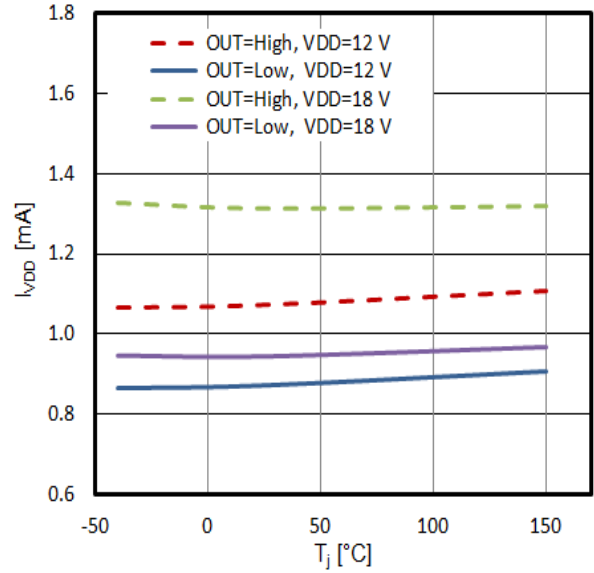

7. Typical quiescent current vs supply voltage

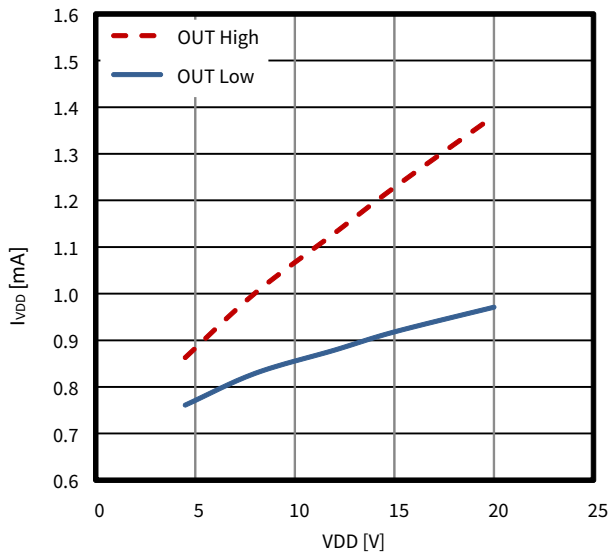

8. Total operating current consumption with capacitive load vs frequency

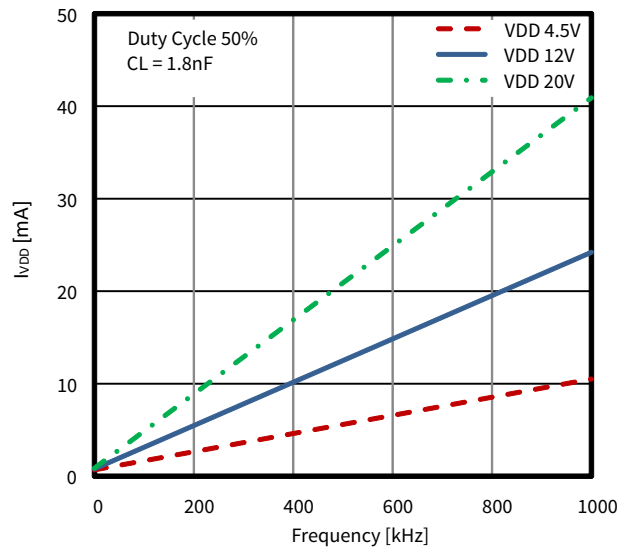

5 Typical characteristics

9. Typical propagation delay vs temperature

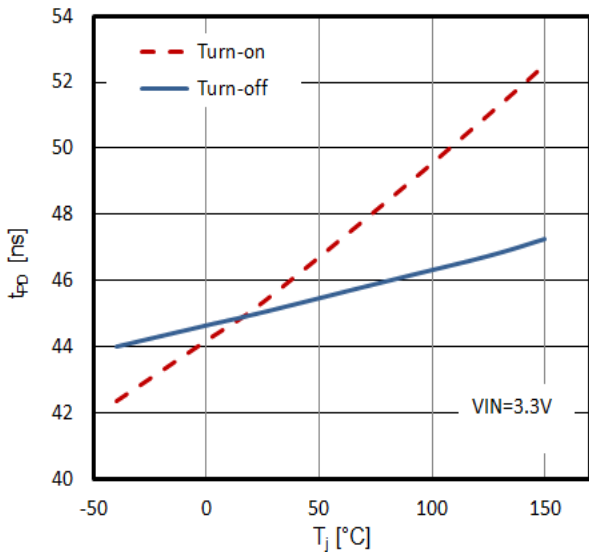

10. Typical rise and fall time vs temperature

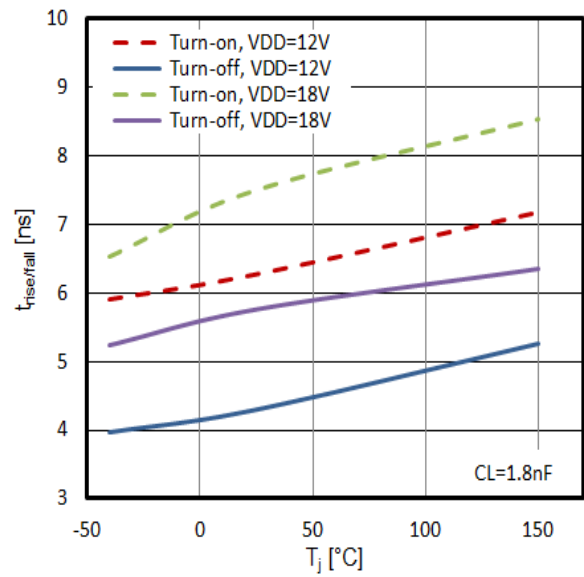

6 Application and implementation

6 Application and implementation

Note: The following information is given as an example for the implementation of the device only and shall not be regarded as a description or warranty of a certain functionality, condition or quality of the device

6.1 Input resistor dimensioning

Table 16 is a lookup table that shows the required input resistor configuration for R_{in1} and R_{in2} (values, form factor and accuracy) depending on the controller PWM output voltage and the required ground shift robustness (static and dynamic CMR). It can be also used to check the maximum allowed CMR, given a certain resistor and controller configuration.

Table 16 Input resistor configuration lookup table

Controller PWM output voltage	Input resistor configuration			Ground shift robustness	
	Value	Tolerance	Form factor ¹⁹⁾	CMR static ²⁰⁾	CMR dynamic
2.5 V	24 kΩ	1%	≥0402	-30 V/+30 V	±150 V
		0.1%	≥0603	-54 V/+63 V	±150 V
3.3 V	33 kΩ	1%	≥0402	-40 V/+40 V	±150 V
		0.1%	≥0603	-72 V/+84 V	±150 V
5 V	51 kΩ	1%	≥0603	-60 V/+60 V	±150 V
		0.1%	≥0805	-108 V/+126 V	±200 V
12 V	127 kΩ	1%	≥0805	-140 V/+140 V	±200 V
		1%	≥1206	-140 V/+140 V	±400 V
		0.1%	≥1206	-200 V/+200 V	±400 V
15 V	160 kΩ	1%	≥0805	-150V/+150 V	±200 V
		1%	≥1206	-175 V/+175 V	±400 V
		0.1%	≥1206	-200 V/+200 V	±400 V

Note: For further information please see the Application Note of EiceDRIVER™ 1EDNx550 single channel with truly differential inputs found in reference [1]

6.2 Half-bridge driving

The EiceDRIVER™ 1EDNx550 is designed to drive low-side MOSFETs in applications with AC ground-shift between the controller IC and the driver. However, its properties also make it suitable for use in half-bridge or full-bridge configurations, as shown in Figure 8. The EiceDRIVER™ 1EDNx550 can effectively drive high-side devices, replacing level-shift gate driver ICs in half and full-bridge topologies.

In the half-bridge structure in Figure 8, when the high-side switch is conducting, a DC offset equal to V_{BUS} occurs between the ground of the high-side driver (i.e. the phase node) and the controller ground. The differential behavior of the EiceDRIVER™ 1EDNx550 enables to handle the floating voltage at the switching node up to the

¹⁹⁾ Please check PWM signal duty cycle and resistor power rating

²⁰⁾ Driver ground to system ground

6 Application and implementation

CMR static level stated in [Table 16](#) (e.g. up to 84 V for 3.3 V PWM outputs and 33 kΩ ±0.1% input resistors in 0603 form factor). Common applications are buck converters, full-bridge converters, synchronous rectifiers and motor drive stages.

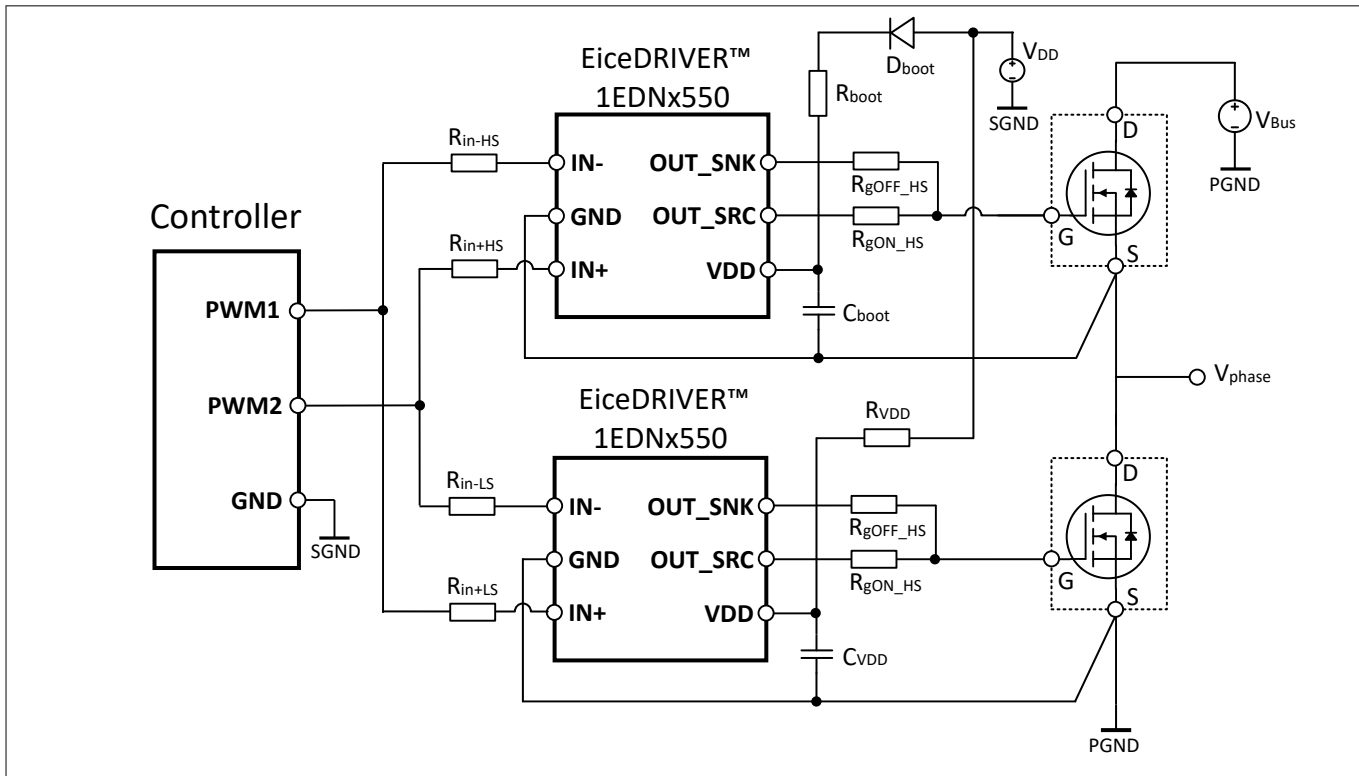

Figure 8 EiceDRIVER™ 1EDNx550 in half-bridge applications

6.3 Switches with Kelvin-source connection (4-pin packages)

The 4-pin configuration depicted in [Figure 9](#) is a very effective measure to improve the switching performance of transistors in packages with high source inductance L_S as is typical for the widely used TO packages. Although the Kelvin-source connection SS solves the problem of the largely increased switching losses due to L_S , it is evident that the gate driver reference potential moves by an inductive voltage drop, V_{LS} with respect to the system ground, SGND. In fast-switching applications at high current, V_{LS} can reach 100 V and above. This is the reason 4-pin systems so far either used isolated drivers or external filters with relatively low corner frequency that add significant signal delay. The EiceDRIVER™ 1EDNx550 is effective in this use case and provides an optimum solution.

[Figure 9](#) also indicates that the usually SGND-related V_{DD} cannot be used directly as the driver supply. But due to the high frequency of V_{LS} (> 100 MHz), a filter composed of impedance Z_{VDD} together with the bypass capacitor C_{VDD} is well suited to generate a sufficiently stable driver supply. Z_{VDD} can be either a resistor (e.g. 22 Ω with a typical C_{VDD} of 1 μF) or a proper ferrite bead.

6 Application and implementation

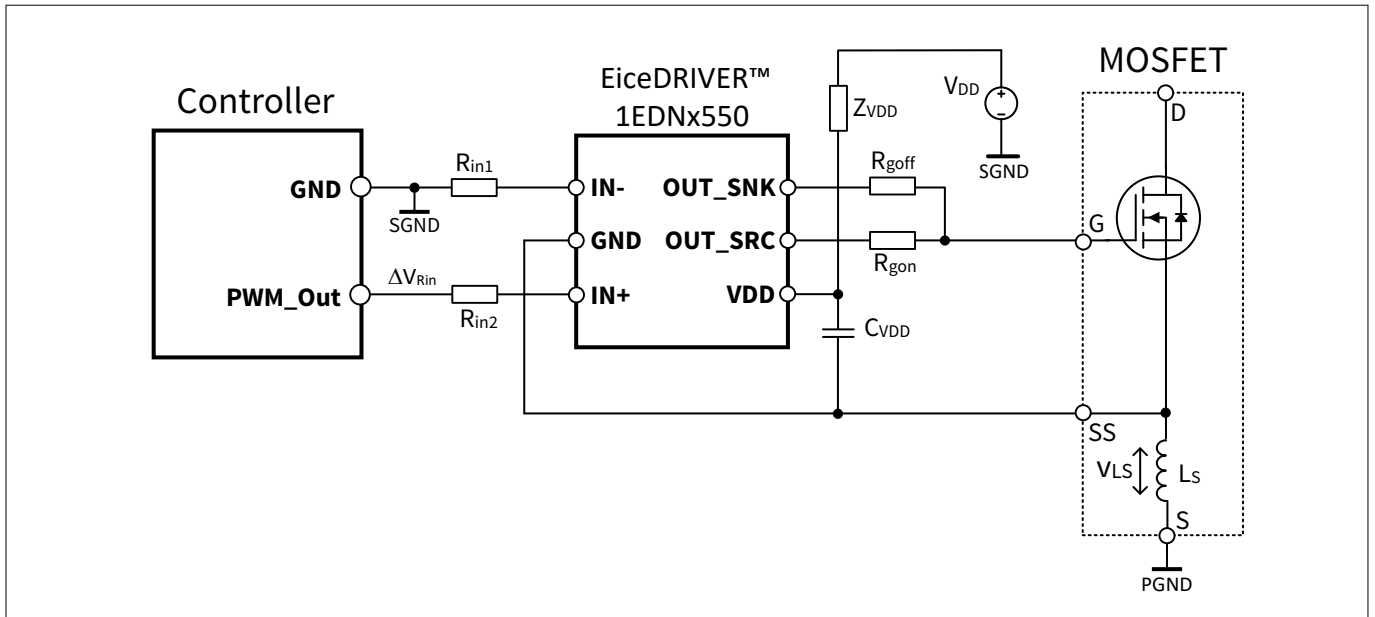

Figure 9 EiceDRIVER™ 1EDNx550 driving a Kelvin-source 4 pin MOSFET

6.4 Applications with significant parasitic PCB-inductances

In fast switching power systems the parasitic inductance associated with any electrical connection may cause significant inductive voltage drops, particularly if the PCB-layout cannot be optimized or if the controller and the power stage are located on two different PCBs.

In such situations, the high robustness of EiceDRIVER™ 1EDNx550 against switching noise and ground shifts is extremely valuable and allows good performances even in systems with poor PCB layouts.

Figure 10 indicates the most relevant parasitic PCB-inductances and how the EiceDRIVER™ 1EDNx550 can be configured in this application.

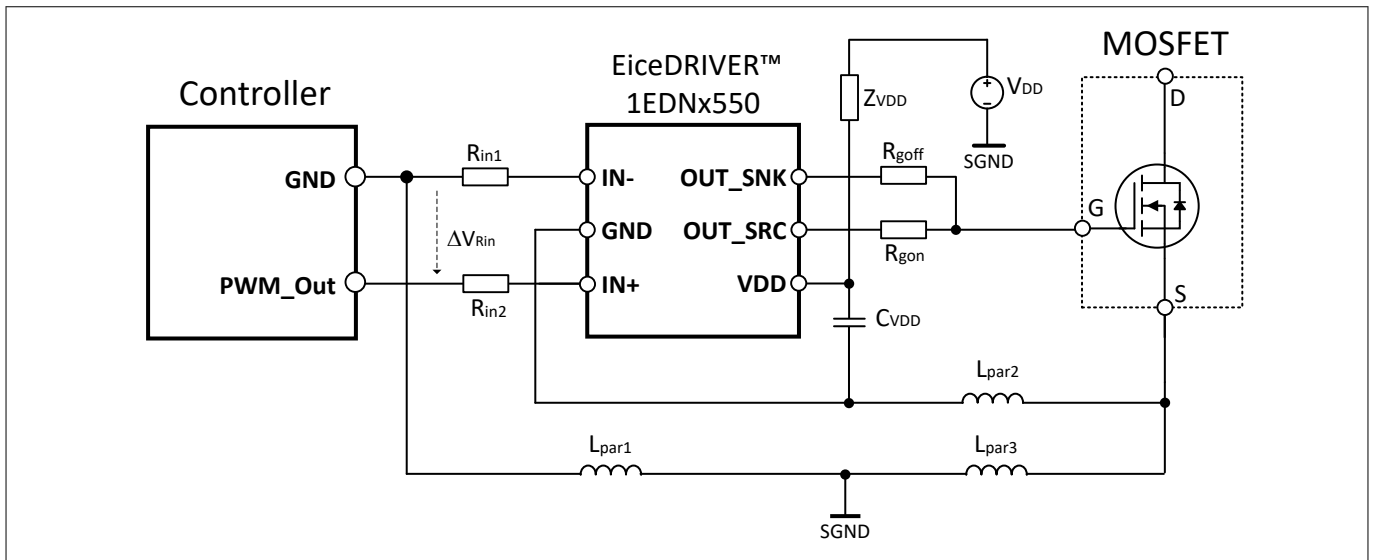

Figure 10 EiceDRIVER™ 1EDNx550 in applications with significant PCB inductances

6 Application and implementation

6.5 Switches with bipolar gate drive

Although most power switches operate at zero “off” gate to source voltage, a negative V_{gs} could be required for some devices by specifications or to prevent induced turn-on in case of fast voltage transients or charge injection on the gate node. Consequently, a bipolar supply voltage rail can be required for the gate driver to ensure proper MOSFETs, SiC, and GaN driving.

EiceDRIVER™ 1EDNx550 can easily drive power switches requiring bipolar V_{gs} voltage: Figure 11 shows a layout-effective method to create two supplies out of a single one through a biased Zener diode. In this simple configuration, the bias voltage V_B defines the positive V_{gs} driving voltage, while the negative V_{gs} driving voltage is given by the voltage difference $V_B - V_{DD}$.

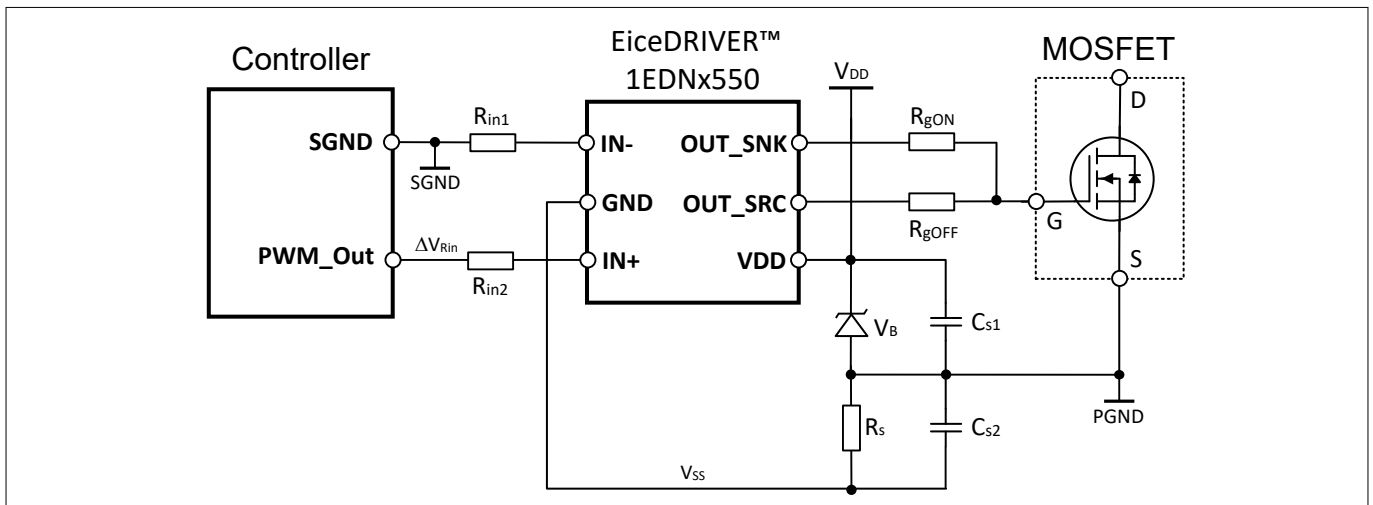

Figure 11 Bipolar gate drive for 3-pin MOSFET

7 Layout guidelines

7 Layout guidelines

It is well-known that the layout of a fast-switching power system is a critical task with strong influence on the overall performance. This is why there exists a huge number of rules, recommendations, guidelines, tips and tricks that should help to finally end up with a proper system layout.

EiceDRIVER™ 1EDNx550 simplifies the design of the grounding network. Maximum performance and CMR capabilities provide a specific input resistor configuration and can be achieved by the following design rules:

- place input resistors R_{in} close to the driver and make layout of input signal path as symmetric and as compact as possible
- use a low-ESR decoupling capacitance for the V_{DD} supply and place it as close as possible to the driver
- minimize power loop inductance as the most critical limitation of switching speed due to the resulting unavoidable voltage overshoots

A layout recommendation for the input path of the SOT23-6 package version is given in [Figure 12](#).

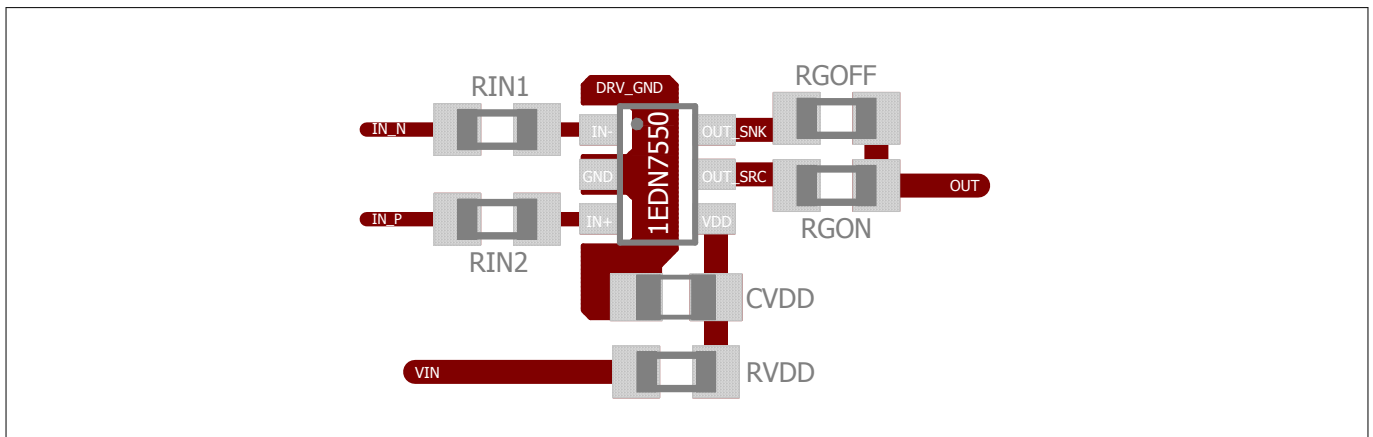

Figure 12 Layout recommendation for SOT23-6 package

As in the case of the TSNP-6 package routing in a single PCB layer is not possible, the layout can be changed according to [Figure 13](#). The chosen form factor of the input resistors (0603) allows to utilize the full dynamic common-mode input range of ± 150 V.

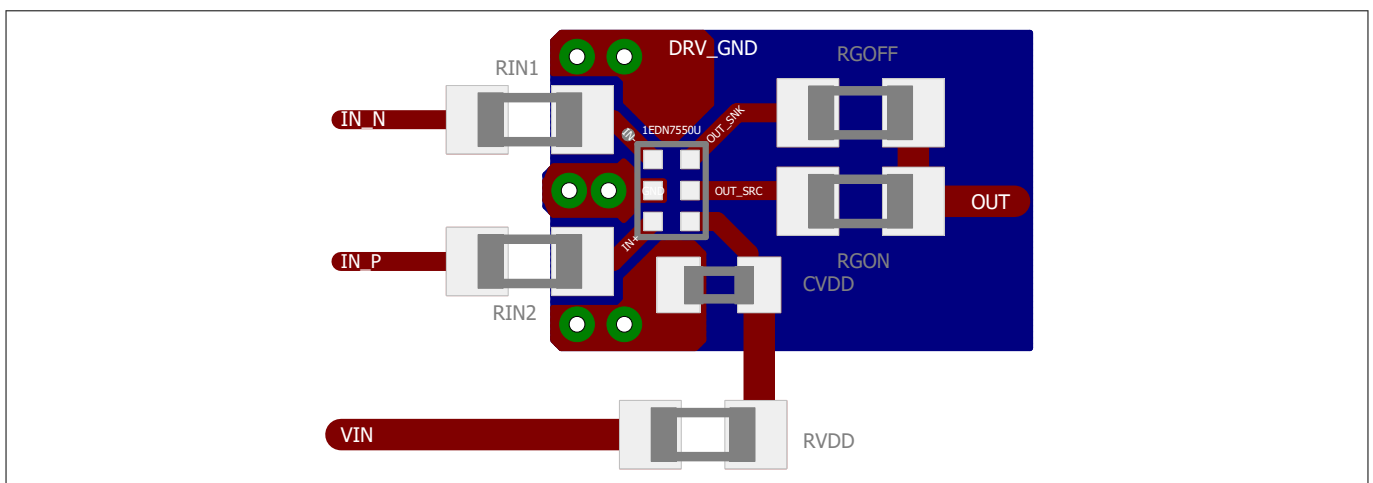

Figure 13 Layout recommendation for TSNP-6 package with SMD resistor 0603

7 Layout guidelines

For applications that do not require the maximum CMR an even more compact layout utilizing resistors of form factor 0402 is shown in [Figure 14](#).

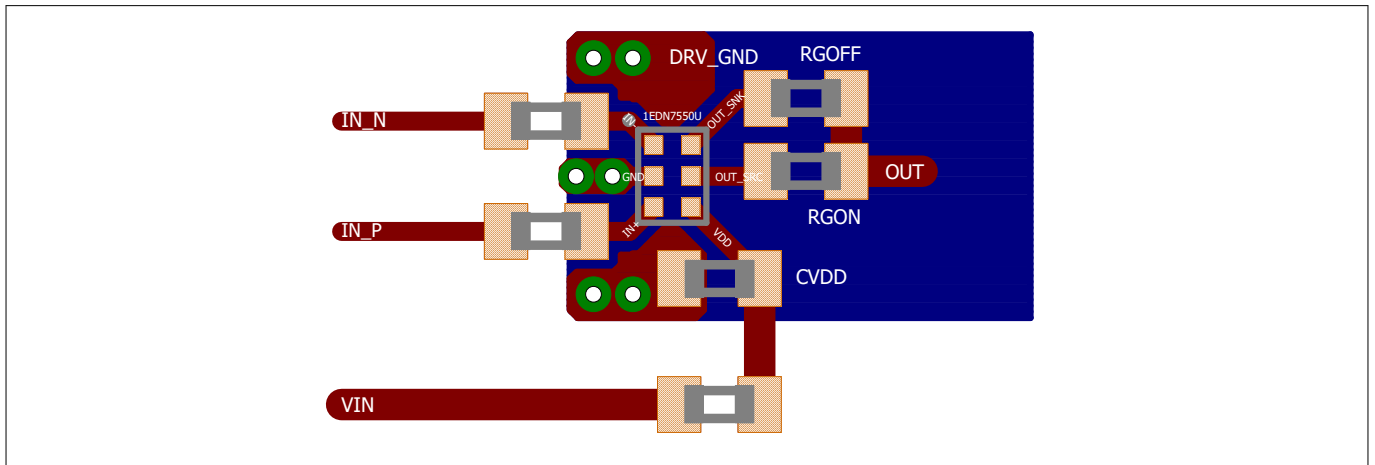

Figure 14 **Layout recommendation for TSNP-6 package with SMD resistor 0402**

For further layout recommendations for TSNP-6, see Recommendations for Printed Circuit Board Assembly of Infineon TSLP/TSSLP/TSNP Packages [\[2\]](#).

When conductive pollution could occur, please consider coating for PCB in order to prevent the leakage current over external resistor pair that might reduce its accuracy.

8 Package information

8 Package information

8.1 Device numbers and markings

Table 17 Device numbers and markings

Part number	Orderable part number (OPN)	Device marking
1EDN7550U	1EDN7550UXTSA1	70
1EDN7550B	1EDN7550BXTSA1	70
1EDN8550B	1EDN8550BXTSA1	80
1EDN6550B	1EDN6550BXTSA1	60
1EDN9550B	1EDN9550BXTSA1	90

8.2 PG-SOT23-6 package

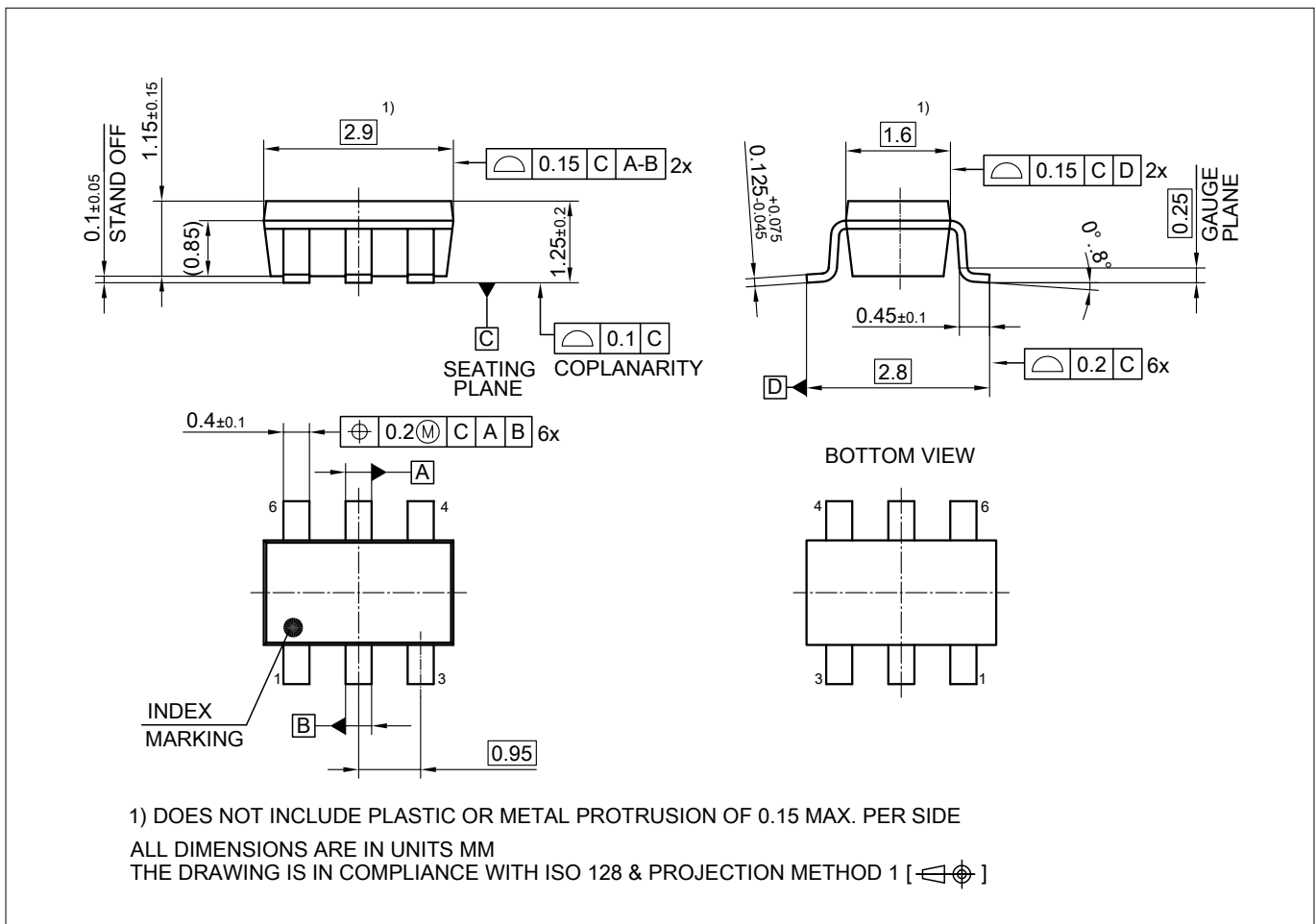

Figure 15 PG-SOT23-6 outline

8 Package information

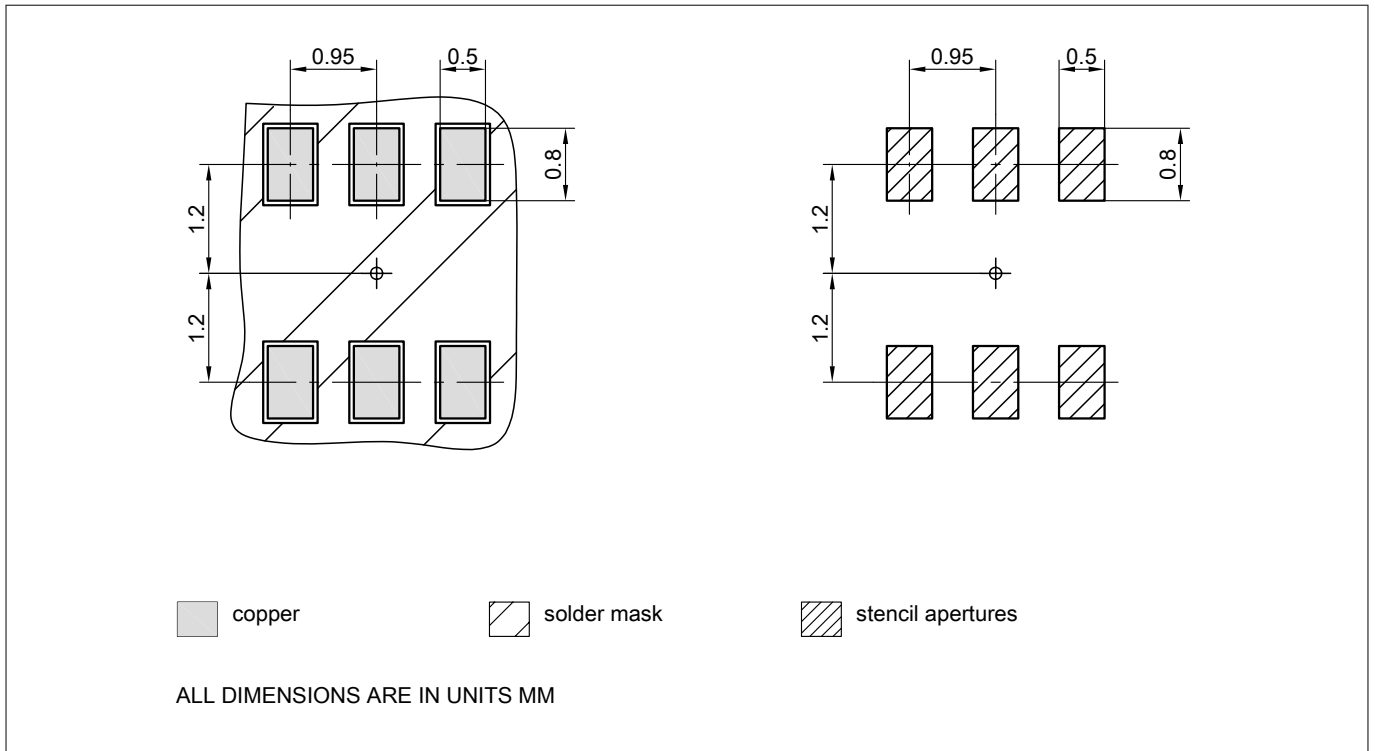

Figure 16 PG-SOT23-6 footprint

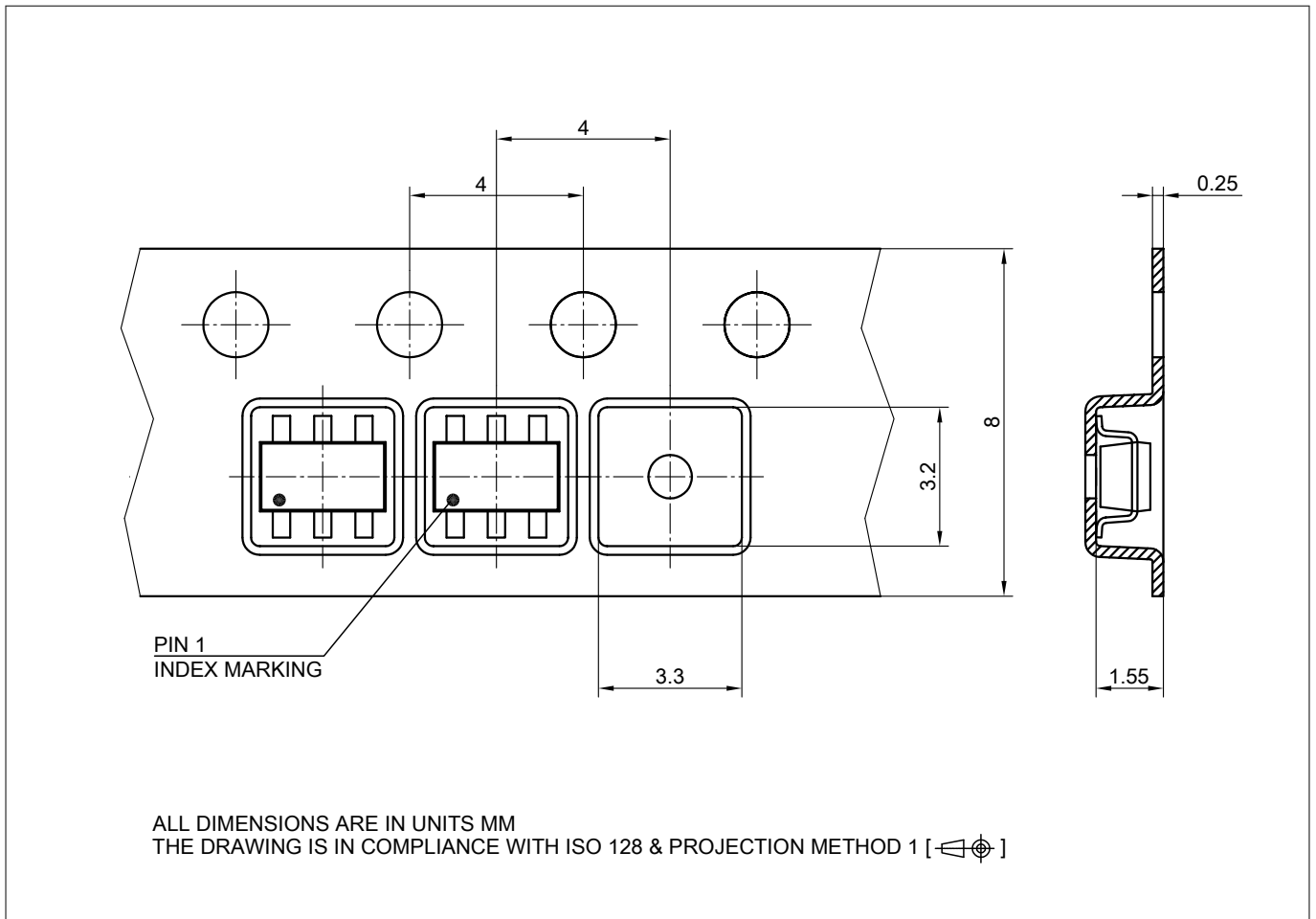

Figure 17 PG-SOT23-6 packaging

8 Package information

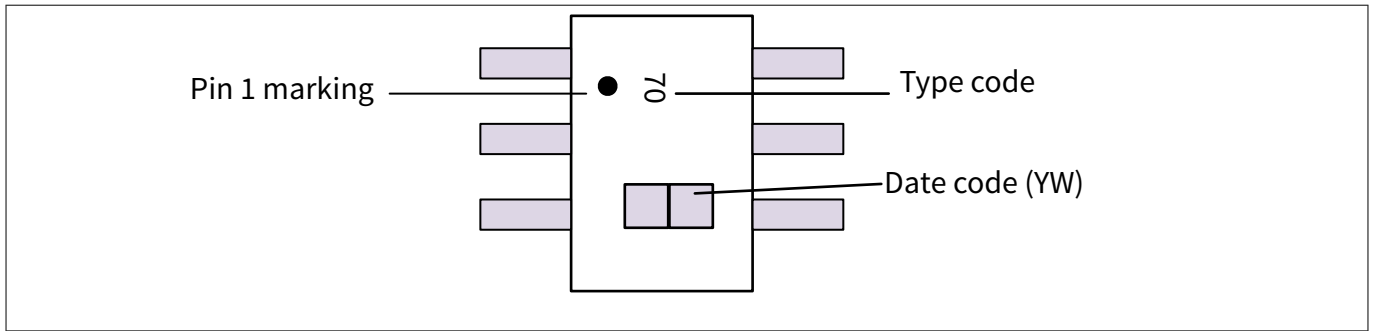

Figure 18 Package marking (PG-SOT23-6)

Note: Date code digits Y and W in Table 18 and Table 19

Table 18 Year date code marking - digit "Y"

Year	Y	Year	Y	Year	Y
2000	0	2010	0	2020	0
2001	1	2011	1	2021	1
2002	2	2012	2	2022	2
2003	3	2013	3	2023	3
2004	4	2014	4	2024	4
2005	5	2015	5	2025	5
2006	6	2016	6	2026	6
2007	7	2017	7	2027	7
2008	8	2018	8	2028	8
2009	9	2019	9	2029	9

Table 19 Week date code marking - digit "W"

Week	W	Week	W	Week	W	Week	W	Week	W
1	A	12	N	23	4	34	h	45	v
2	B	13	P	24	5	35	j	46	x
3	C	14	Q	25	6	36	k	47	y
4	D	15	R	26	7	37	l	48	z
5	E	16	S	27	a	38	n	49	8
6	F	17	T	28	b	39	p	50	9
7	G	18	U	29	c	40	q	51	2
8	H	19	V	30	d	41	r	52	3
9	J	20	W	31	e	42	s	-	-
10	K	21	Y	32	f	43	t	-	-
11	L	22	Z	33	g	44	u	-	-

8 Package information

8.3 PG-TSNP-6 package

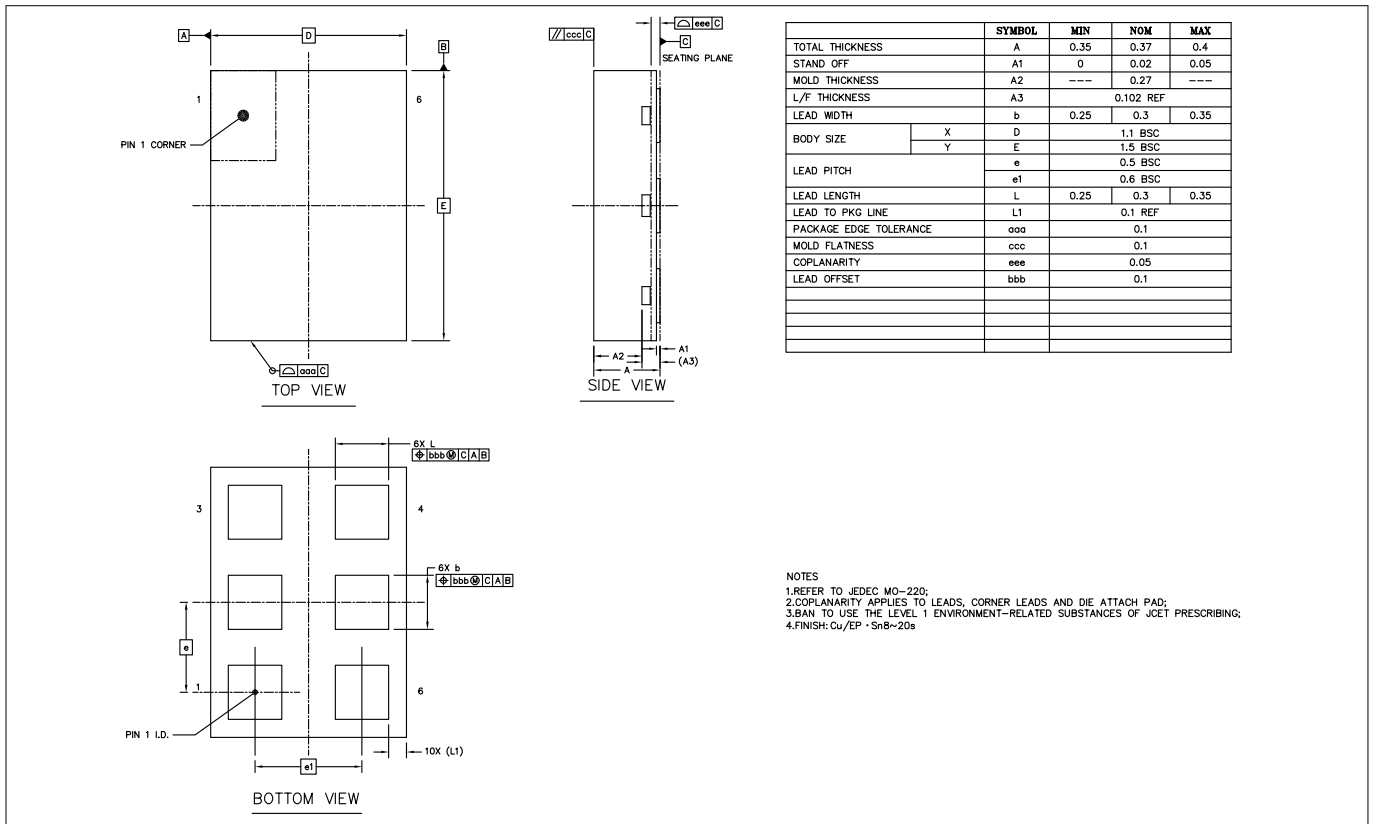

Figure 19 TSNP-6 outline

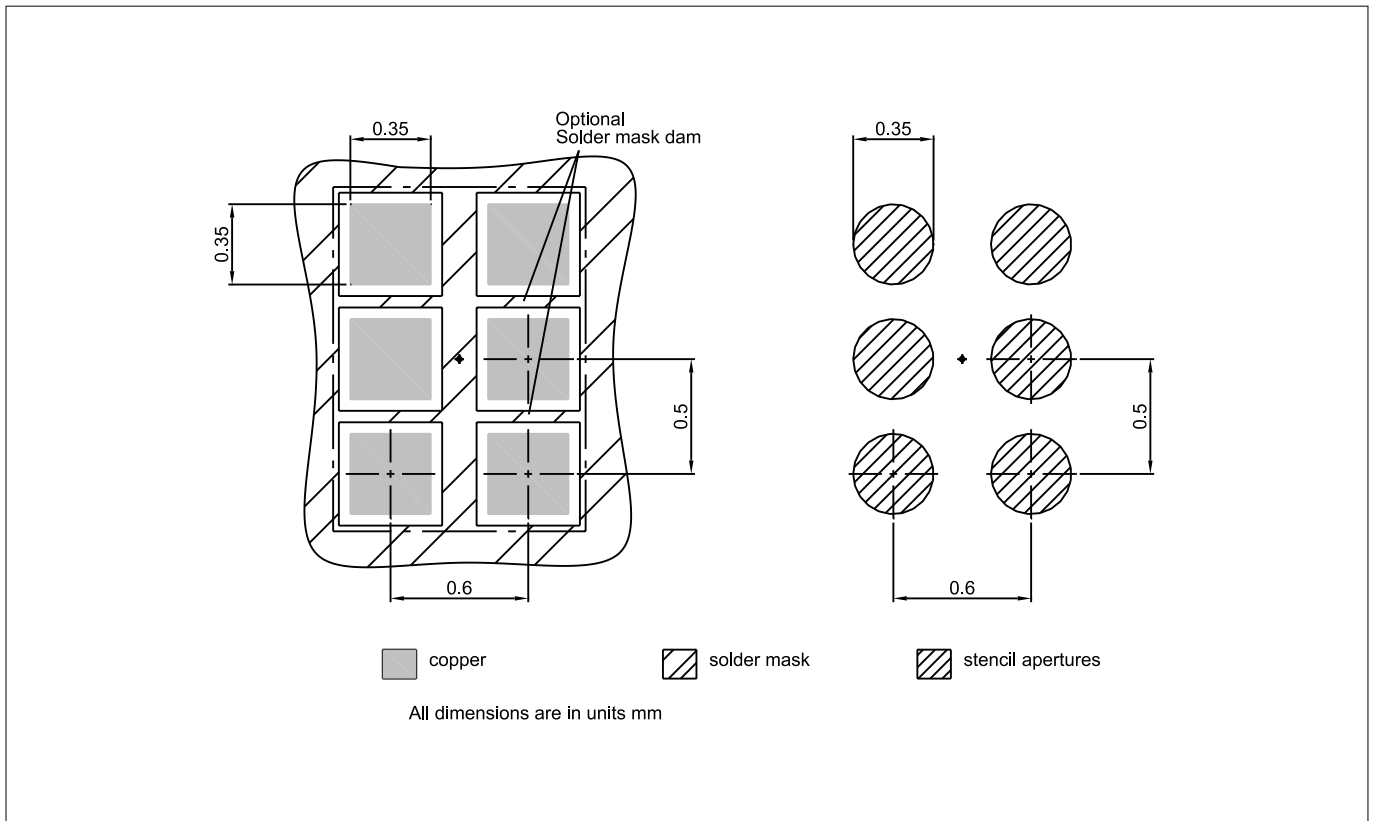

Figure 20 TSNP-6 footprint

8 Package information

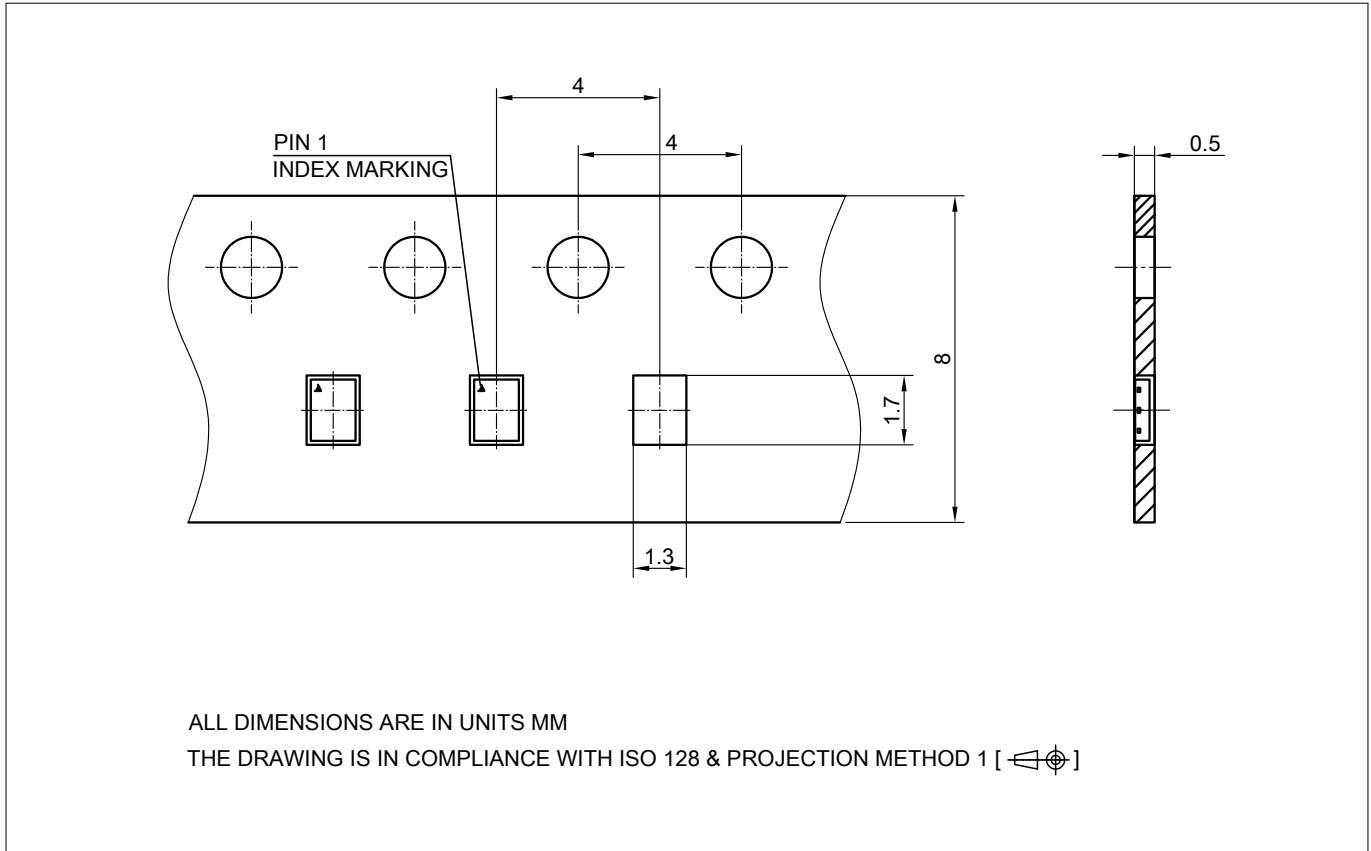

Figure 21 **TSNP-6 packaging**

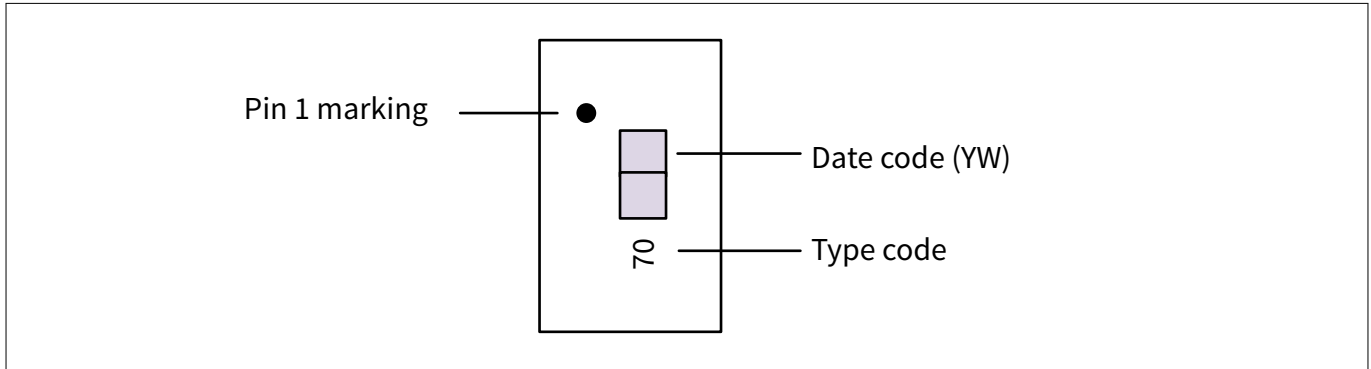

Figure 22 **Package marking (TSNP-6)**

Note: *Date code digits Y and W in [Table 18](#) and [Table 19](#)*

Further information on packages: www.infineon.com/packages

9 List of abbreviations

Table 20 List of abbreviations

Acronym	Description
CMR	common-mode robustness
CMRR	common-mode rejection ratio
ESD	electrostatic discharge
ESR	equivalent series resistance
GND	ground
GaN	gallium nitride
LPF	low pass filter
OPN	orderable part number
PCB	printed circuit board
SiC	silicon carbide
SOT	small outline transistor
SMD	surface mount device
TDI	truly differential input
TO	transistor outline
TSNP	thin small discrete package
UVLO	undervoltage lockout

References

- [1] Infineon *Applications of 1EDNx550 single-channel low-side EiceDRIVER™ with truly differential inputs (Rev.1.1)*, 2019-08-07, [[Infineon-ApplicationNote_EiceDRIVER_1EDN_TDI_1EDNx550](#)]
- [2] Infineon *Recommendations for Printed Circuit Board Assembly of Infineon TSLP/TSSLP/TSNP Packages*, June 2010, [[Recommendations for printed circuit board assembly of Infineon TSLP/TSSLP/TSNP packages](#)]

Revision history

Revision history

Document version	Date of release	Description of changes
Rev.2.4	2024-02-17	<ul style="list-style-type: none"> Updated Table 6: Junction-board specifications Updated Figure 19
Rev.2.3	2021-11-12	<ul style="list-style-type: none"> Specifications of 1EDN7550B, 1EDN8550B and 1EDN7550U not changed Added new product variants 1EDN6550B and 1EDN9550B Updated maximum CMR range to ± 200 V static, ± 400 V dynamic Editorial enhancement of layout and descriptions on front cover Editorial enhancement of Pin configuration Table 2 Editorial enhancement of Functional description in Chapter 3 Corrected typo I_{SNK_rev} Table 4 Added $UVLO_{off}$ min. values for all product variants Corrected typos in Test circuit Figure 5 Updated Figure: Typical propagation delay vs temperature in Chapter 5 Editorial enhancement in Application and implementation Chapter 6 Added Table 16 in Chapter 6.1 Added Half-bridge driving in Chapter 6.2 Editorial enhancement in Layout guidelines Chapter 7 Chapter Device numbers and markings moved to Chapter 8.1 Added list of abbreviations in Chapter 9
Rev.2.2	2019-12-19	<ul style="list-style-type: none"> Added new product 1EDN7550U with package TSNP-6 On front cover "Features", added reference to application note (Applications of 1EDNx550 single-channel lowside EiceDRIVER™ with truly differential inputs.) for input PWM signal voltage levels other than 3.3 V Added Table 3, Logic table Corrected footnote in Table 4 V_{ESD_HDM} Updated Max. value in Table 4 V_{ESD_CDM} and added footnote Updated Thermal characteristics in Table 5 and added Table 6 Updated Typ. values for Table 8 and added footnotes for Table 15 Added Figure 5 for Test circuit Added layout recommendations for TSNP package Figure 13 and Figure 14 Added package marking for SOT23 Figure 18 and code marking tables Table 18, Table 19 Added package marking for TSNP Figure 22 Added Chapter 8.1, Device numbers and markings

Revision history

Document version	Date of release	Description of changes
Rev. 2.1	2019-11-28	<ul style="list-style-type: none"> Parameter split in Table 4 Voltage at pins OUT_SRC and OUT_SNK → Voltage at pin OUT_SRC and Voltage at pin OUT_SNK and specified min. and max. Corrected typo in Table 4 V_{ESD_CDM} To match pin configurations in Figure 2 update of Figure 1 as well as in Chapter 5 the Figure 9 to former Figure: 1EDNx550 as a high-side driver in former Chapter: High-side switches Updated diagram according to number of OUT pins → OUTx, Figure 7 CLoad → CL for Fig 12 and Fig 14 Updated to latest package diagrams, Chapter 8
Rev. 2.0	2018-05-14	Final Datasheet created

Trademarks

All referenced product or service names and trademarks are the property of their respective owners.

Edition 2024-02-17

Published by

Infineon Technologies AG

81726 Munich, Germany

© 2024 Infineon Technologies AG

All Rights Reserved.

Do you have a question about any aspect of this document?

Email: erratum@infineon.com

Document reference

IFX-vbg1622805011331

Important notice

The information given in this document shall in no event be regarded as a guarantee of conditions or characteristics ("Beschaffheitsgarantie").

With respect to any examples, hints or any typical values stated herein and/or any information regarding the application of the product, Infineon Technologies hereby disclaims any and all warranties and liabilities of any kind, including without limitation warranties of non-infringement of intellectual property rights of any third party.

In addition, any information given in this document is subject to customer's compliance with its obligations stated in this document and any applicable legal requirements, norms and standards concerning customer's products and any use of the product of Infineon Technologies in customer's applications.

The data contained in this document is exclusively intended for technically trained staff. It is the responsibility of customer's technical departments to evaluate the suitability of the product for the intended application and the completeness of the product information given in this document with respect to such application.

Warnings

Due to technical requirements products may contain dangerous substances. For information on the types in question please contact your nearest Infineon Technologies office.

Except as otherwise explicitly approved by Infineon Technologies in a written document signed by authorized representatives of Infineon Technologies, Infineon Technologies' products may not be used in any applications where a failure of the product or any consequences of the use thereof can reasonably be expected to result in personal injury.