



AIROC™ CYW43022 Wi-Fi 5 + Bluetooth® 5.4 combo

Ultra-low-power solution for IoT applications needing long battery life.

Infineon delivers market-proven AIROC™ Wi-Fi and Bluetooth® System on Chip combos with robust, reliable, and secure wireless connectivity. Infineon is the industry leader in Wi-Fi for the IoT with over 1 billion wireless devices in the field, over the last 20 years, making AIROC™ the most deployed wireless IP in the industry. Infineon's broad portfolio consists of Wi-Fi 4 (802.11n), Wi-Fi 5 (802.11ac), and Wi-Fi 6 (802.11ax) + Bluetooth® combo devices including variants supporting SISO (1x1) or MIMO (2x2), single-band 2.4 GHz or dual-band 2.4/5 GHz, as well as a host of differentiated feature sets including best-in-class range, smart coexistence, ultra-low power consumption, enhanced security, and more.

AIROC™ CYW43022 1x1 dual-band (2.4/5 GHz) Wi-Fi 5 (802.11ac) + Bluetooth® 5.4 is an ultra-low-power connectivity device designed to address IoT designs needing minimal power consumption and compact size. Applications such as wearables, IP cameras, and smart door locks are ideally suited for CYW43022 with its low transmit/receive power and optimized Deep Sleep mode. An embedded Bluetooth® stack and Wi-Fi networking offloads allow CYW43022 to save system-level power by handling Bluetooth® and Wi-Fi connectivity activity without the involvement of a host processor.

AIROC™ CYW43022 supports Linux, Android, and RTOS designs, with the ability to pair with Infineon's ultra-low-power, flexible, and secure PSoc™ 6 MCUs within ModusToolbox™ software and tools as well as third-party A-Class and M-Class MCUs.

Multiple Infineon wireless module partners are in production for fast time-to-market; for a complete list, see the [Infineon Wi-Fi Bluetooth® Partner Module Product Selector Guide](#) or visit the [AIROC™ CYW43022 webpage](#).

AIROC™ CYW43022 benefits

- Ultra-low-power for applications maximizes battery life
- Embedded Bluetooth® stack and Wi-Fi network offloads
- Optional internal 32-kHz low-power oscillator saves power and BOM costs
- Dual-band (2.4/5 GHz) helps manage congestion
- +20dBm Bluetooth® transmit power for applications with limited antennas
- Built on market-proven wireless IP – maximum interoperability
- Supports concurrent Wi-Fi and Bluetooth® connectivity use cases and coexistence
- Reduction in development time with Wi-Fi software enablement for RTOS, Linux, and Android designs with multiple hosts supported
- Rapid time-to-market with multiple partner modules integrating AIROC™ CYW43022 with full global certifications, reference platforms, and more
- Direct access to online application support engineers in the [Infineon Developer Community](#)

Key benefits

Wi-Fi features:

- Wi-Fi 5 (802.11ac)
- 1 x 1 dual-band (2.4/5 GHz)
- 20-MHz channels, up to 78-Mbps PHY data rate
- Integrated internal PA and LNA switch support a single antenna shared between Wi-Fi and Bluetooth®
- Network offloads for low-power host offload
- Ultra-low-power deep sleep

Bluetooth® features:

- Class 1 (100 m) and Class 2 (10 m) operation, +20dBm Tx power
- Bluetooth® 5.4, supports BDR (1 Mbps), EDR (2/3 Mbps), and Bluetooth® LE
- Embedded stack for low-power host offload

General features:

- SDIO v 2.0/v 3.0 host interface (Shareable across Wi-Fi and Bluetooth®)
- SPI host interface
- HCI over UART/SPI for Bluetooth®
- 40 GPIOs
- Supports WPA3 R3 security

PRODUCT BRIEF

Key applications

Smart home	IP cameras, smart doorbells, smart door locks, smart thermostats
Wearables	Smart watches, fitness trackers, AR glasses
Smart medical/healthcare	Blood pressure monitors, portable medical monitors

Product summary

Name	Description	Temp range	Package
AzureWave AW-AM617 wireless module	Certified module from AzureWave using CYW43022	-20°C to +70°C	12 x 12 x 1.75 mm module
CYW43022CUBT	Dual-band Wi-Fi 5 + Bluetooth® 5.4 combo SoC (WLGBA)	-20°C to +70°C	106-ball WLBGA (3.76 x 4.43 mm, 0.35-mm ball pitch)
CYW43022CWBT	Dual-band Wi-Fi 5 + Bluetooth® 5.4 combo SoC (WLCSP)	-20°C to +70°C	251-pin WLCSP (3.76 x 4.43 mm, 0.2-mm ball pitch)
Murata type 2GF wireless module	Certified module from Murata using CYW43022	-20°C to +70°C	10.0 x 7.2 x 1.4 mm module
USI WM-BAC-CYW-22	Certified module from USI using CYW43022	-20°C to +70°C	7.9 x 7.3 x 1.1 mm

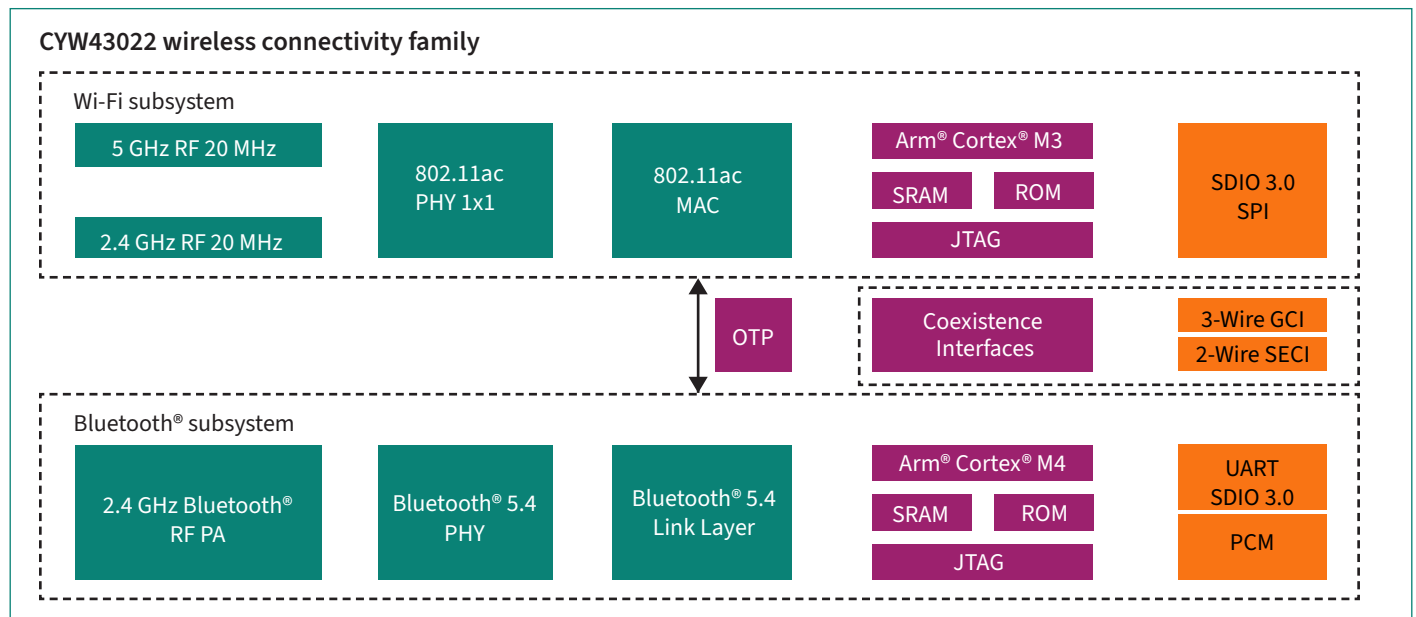

www.infineon.com

Published by
Infineon Technologies AG
Am Campeon 1-15, 85579 Neubiberg
Germany

© 2024 Infineon Technologies AG
All rights reserved.

Public

Document number: 002-37235 REV. *E
Date: 07/2024

Please note!

This Document is for information purposes only and any information given herein shall in no event be regarded as a warranty, guarantee or description of any functionality, conditions and/or quality of our products or any suitability for a particular purpose. With regard to the technical specifications of our products, we kindly ask you to refer to the relevant product data sheets provided by us. Our customers and their technical departments are required to evaluate the suitability of our products for the intended application.

We reserve the right to change this document and/or the information given herein at any time.

Additional information

For further information on technologies, our products, the application of our products, delivery terms and conditions and/or prices, please contact your nearest Infineon Technologies office (www.infineon.com).

Warnings

Due to technical requirements, our products may contain dangerous substances. For information on the types in question, please contact your nearest Infineon Technologies office.

Except as otherwise explicitly approved by us in a written document signed by authorized representatives of Infineon Technologies, our products may not be used in any life-endangering applications, including but not limited to medical, nuclear, military, life-critical or any other applications where a failure of the product or any consequences of the use thereof can result in personal injury.