

MOTIX™ full-bridge ICs BTM90xxEP Arduino Shield

User guide

About this document

Scope and purpose

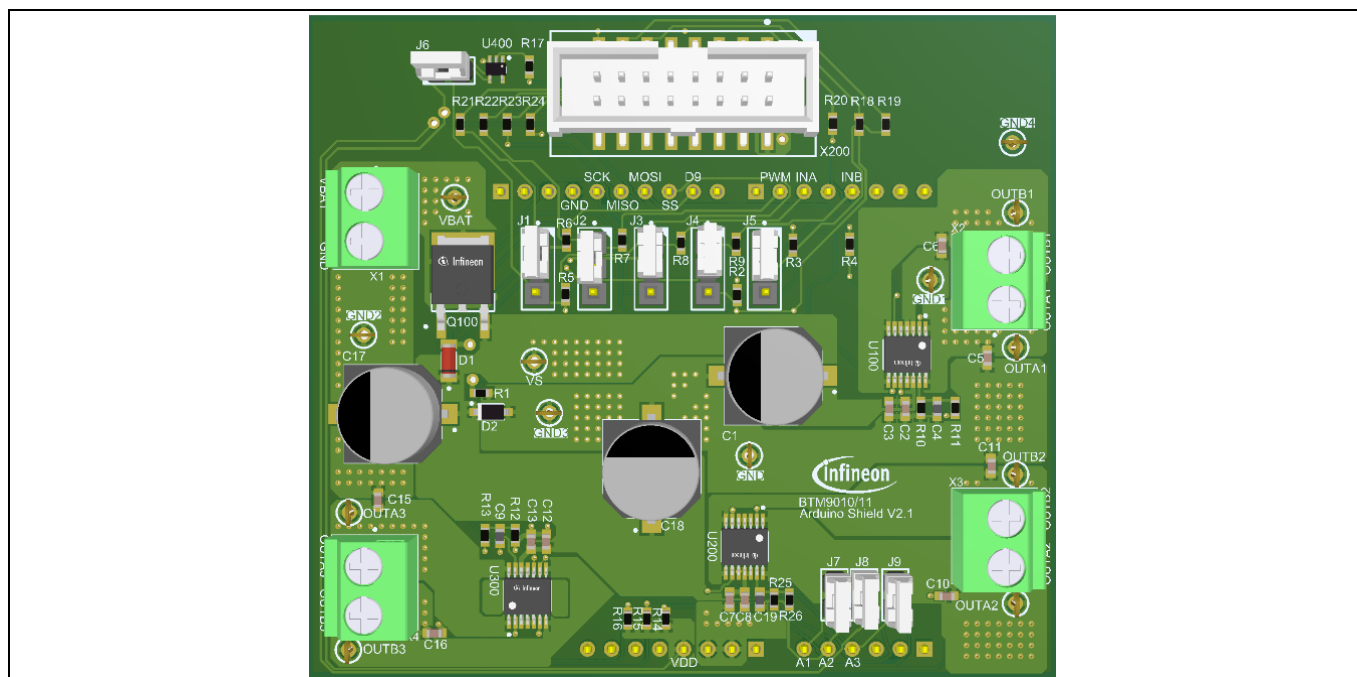

Figure 1 Board overview

This user guide introduces the features of the evaluation board MOTIX™ Full-bridge ICs BTM90xxEP Arduino Shield. It helps users evaluate hardware and software functionality of the MOTIX™ full-bridge ICs BTM90xxEP.

Intended audience

This document is intended for engineers working with the MOTIX™ full-bridge ICs BTM90xxEP.

Evaluation board

This board is used during design-in, for evaluation and measurement of characteristics, and proof of datasheet specifications.

Related information

Table 1 Related information

Reference	Description
Arduino UNO	Information on Arduino UNO board
Arduino IDE	Details on Arduino IDE
uIO-Stick	Details on the debug interface

Reference	Description
Infineon Developer Center Launcher	Details on the tool

Important Notice

"Evaluation boards and reference boards" mean products embedded on a printed circuit board (PCB) for demonstration and / or evaluation purposes, which include, without limitation, demonstration, reference and evaluation boards, kits and design (collectively referred to as "reference board").

Environmental conditions have been considered in the design of the evaluation boards and reference boards provided by Infineon Technologies. The design of the evaluation boards and reference boards has been tested by Infineon Technologies only as described in this document. The design is not qualified in terms of safety requirements, manufacturing and operation over the entire operating temperature range or lifetime.

The evaluation boards and reference boards provided by Infineon Technologies are subject to functional testing only under typical load conditions. Evaluation boards and reference boards are not subject to the same procedures as regular products regarding returned material analysis (RMA), process change notification (PCN) and product discontinuation (PD).

Evaluation boards and reference boards are not commercialized products, and are solely intended for evaluation and testing purposes. In particular, they may not be used for reliability testing or production. The evaluation boards and reference boards may therefore not comply with CE or similar standards (including but not limited to the EMC Directive 2004/EC/108 and the EMC Act) and may not fulfill other requirements of the country in which they are operated by the customer. The customer must ensure that all evaluation boards and reference boards will be handled in a way which is compliant with the relevant requirements and standards of the country in which they are operated.

The evaluation boards and reference boards as well as the information provided in this document are addressed only to qualified and skilled technical staff, for laboratory usage, and must be used and managed according to the terms and conditions set forth in this document and in other related documentation supplied with the respective evaluation board and reference board.

It is the responsibility of the customer's technical departments to evaluate the suitability of the evaluation boards and reference boards for the intended application, and to evaluate the completeness and correctness of the information provided in this document with respect to such application.

The customer is obliged to ensure that the use of the evaluation boards and reference boards does not cause any harm to persons or third-party property.

The evaluation boards and reference boards and any information in this document is provided "as is" and Infineon Technologies disclaims any warranties, express or implied, including but not limited to warranties of non-infringement of third-party rights and implied warranties of fitness for any purpose, or for merchantability.





Infineon Technologies may not be responsible for any damages resulting from the use of the evaluation boards and reference boards and/or from any information provided in this document. The customer is obliged to defend, indemnify and hold Infineon Technologies harmless from and against any claims or damages arising out of or resulting from any use thereof.

Infineon Technologies reserves the right to modify this document and/or any information provided herein at any time without further notice.

Safety precautions

Note: Please note the following warnings regarding the hazards associated with development system.

Table 1 Safety precautions

	Caution
	The heat sink and device surfaces of the evaluation or reference board may become hot during testing. Hence, necessary precautions are required while handling the board. Failure to comply may cause injury.
	Only personnel familiar with the drive, power electronics and associated machinery should plan, install, commission and subsequently service the system. Failure to comply may result in personal injury and/or equipment damage.
	The evaluation or reference board contains parts and assemblies sensitive to electrostatic discharge (ESD). Electrostatic control precautions are required when installing, testing, servicing or repairing the assembly. Component damage may result if ESD control procedures are not followed. If you are not familiar with electrostatic control procedures, refer to the applicable ESD protection handbooks and guidelines.
	A drive that is incorrectly applied or installed can lead to component damage or reduction in product lifetime. Wiring or application errors such as under sizing the motor, supplying an incorrect or inadequate AC supply, or excessive ambient temperatures may result in system malfunction.

Warnings

Due to technical requirements products may contain dangerous substances. For information on the types in question please contact your nearest Infineon Technologies office.

Except as otherwise explicitly approved by Infineon Technologies in a written document signed by authorized representatives of Infineon Technologies, Infineon Technologies' products may not be used in any applications where a failure of the product or any consequences of the use thereof can reasonably be expected to result in personal injury.

Table of contents

About this document	1
Important Notice	2
Safety precautions	3
Warnings	3
Table of contents	4
1 MOTIX™ full-bridge ICs BTM90xxEP overview	5
1.1 Key features.....	5
1.2 Device selection.....	5
1.3 Block diagram.....	7
1.4 Pin assignment.....	8
2 Introduction to the evaluation board	9
2.1 Block diagram.....	9
2.2 Main features	9
2.3 Technical data	10
2.4 Target applications	10
2.4.1 Debugger	10
2.4.2 Application with three BTM90x1EP in daisy-chained SPI control	11
2.4.3 Application with daisy-chain SPI configuration and direct input	12
3 System and functional description	14
3.1 Board information.....	14
3.2 Arduino UNO interface	15
3.3 uIO-Stick interface.....	15
4 Design files	16
4.1 Schematics	16
4.2 Layout	17
4.3 Bill of material	18
5 Getting started	20
5.1 Getting started using Arduino UNO board	20
5.1.1 Hardware	20
5.1.2 Software	20
5.2 Getting started using uIO-Stick.....	21
5.2.1 Hardware	21
5.2.2 Software	21
Revision history	23

1 MOTIX™ full-bridge ICs BTM90xxEP overview

The MOTIX™ full-bridge ICs BTM90xxEP are integrated full-bridges for DC motor control applications. BTM90xxEP is implemented in the BCD technology, and assembled in the PG-TSDSO-14 package, which has an exposed pad to achieve good thermal performance.

BTM90xxEP devices have various protection features against overtemperature, undervoltage, overcurrent, short circuit and cross-current. The devices also provide current sense and open-load diagnostic as diagnosis features, and additionally BTM9021EP has a watchdog to supervise the SPI communication. With the IS pin of BTM9010EP/20EP users can supervise the information of the output current and the error flag. Also, the status byte of BTM9011EP/BTM9021EP can provide the error flag for dedicated fault conditions through the SPI.

The BTM90xxEP provides a cost-optimized solution for full-bridge motor control applications with protection and diagnosis features. BTM90xxEP can optimize the overall board-space-consumption. BTM90xxEP can also drive any other inductive, resistive and capacitive loads with specifications that it can fulfill, apart from brushed DC motor control.

1.1 Key features

- Path resistance typ. 175 mΩ @ 25 °C (BTM9010EP/11EP) or typ. 84 mΩ @ 25 °C (BTM9020EP/21EP)
- Supply voltage range from 7 V to 18 V
- Extended supply voltage range from 4.5 V to 40 V
- Current limitation of min. 10 A (BTM9010EP/11EP) or min. 20 A (BTM9020EP/21EP)
- Enhanced switching speed for reduced switching losses
- Adjustable slew rates for optimized EMC performance
- Driver circuit with logic level inputs
- Protection and diagnostics:
overcurrent, undervoltage, overtemperature, open load detection, cross current protection
- Watchdog in BTM9021EP
- Current sense for both high-side and low-side switches
- Status flag diagnosis with current sense capability
- AEC-Q100 qualified (Grade 1)
- Green Product (RoHS compliant)
- PG-TSDSO-14 package

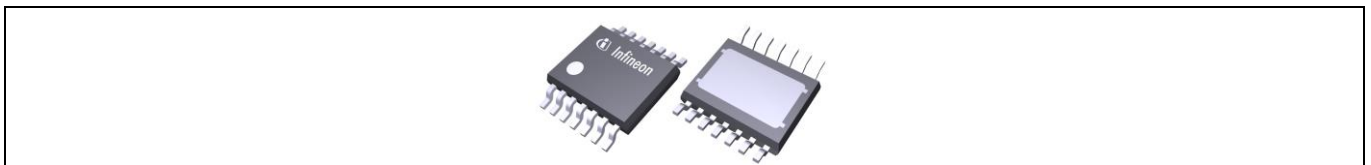

Figure 2 PG-TSDSO-14 package

1.2 Device selection

There are four variants of BTM90xxEP to select based on application targets. Refer to the tables below for device selection.

Table 2 Device comparison BTM9010EP vs. BTM9011EP

	BTM9010EP (HW variant)	BTM9011EP (SPI variant)
Package	PG - TSDSO - 14	PG - TSDSO - 14
Digital interface	INA, INB, SEL, PWM	SDI, SCLK, CS, SDO
Path resistance	175 mΩ at 25°C	175 mΩ at 25°C
Current limitation	Min. 10 A	Min. 10 A
Overcurrent protection	Error flag at IS pin; Latched	Error flag at IS pin; OCx bit latched in the status byte; Dedicate bit for each half-bridge
Slew rate selection	2 configurable slew rate levels: <ul style="list-style-type: none"> Selected through input sequence Read out at IS pin 	2 configurable slew rate levels: <ul style="list-style-type: none"> Selected through SR bit in the control byte Read out the control byte at SDO pin
Undervoltage shutdown	No current flowing out from IS pin; Unlatched	No current flowing out from IS pin; UV bit set but unlatched in the status byte
Overtemperature protection	Error flag at IS pin Unlatched	Error flag at IS pin; TSDx bit set but unlatched in the status byte; Dedicate bit for each half-bridge
Open load detection	Error flag at IS pin Unlatched	Error flag at IS pin; OL bit set but unlatched in the status byte
Current sense	Provided at IS pin	Provided at IS pin
Enter to standby mode	All inputs (INA, INB, SEL and PWM) are set to "Low"	EN bit is set to "Low"

Table 3 Device comparison BTM9020EP vs. BTM9021EP

	BTM9020EP (HW variant)	BTM9021EP (SPI variant)
Package	PG - TSDSO - 14	PG - TSDSO - 14
Digital interface	INA, INB, SEL, PWM	SDI, SCLK, CS, SDO
Path resistance	84 mΩ at 25°C	84 mΩ at 25°C
Current limitation	Min. 20 A	Min. 20 A
Overcurrent protection	Error flag at IS pin; Latched	Error flag at IS pin; OCx bit latched in the status byte; Dedicate bit for each half-bridge
Slew rate selection	2 configurable slew rate levels: <ul style="list-style-type: none"> Selected through input sequence Read out at IS pin 	2 configurable slew rate levels: <ul style="list-style-type: none"> Selected through SR bit in the control byte Read out the control byte at SDO pin
Undervoltage shutdown	No current flowing out from IS pin; Unlatched	No current flowing out from IS pin; UV bit set but unlatched in the status byte
Overtemperature protection	Error flag at IS pin Unlatched	Error flag at IS pin; TSDx bit set but unlatched in the status byte; Dedicate bit for each half-bridge
Open load detection	Error flag at IS pin Unlatched	Error flag at IS pin; OL bit set but unlatched in the status byte

	BTM9020EP (HW variant)	BTM9021EP (SPI variant)
Current sense	Provided at IS pin	Provided at IS pin

1.3 Block diagram

The MOTIX™ full-bridge ICs BTM90xxEP contains two half-bridges with an integrated MOSFET driver ICs implemented with a monolithic solution. As shown in **Figure 3**, two half-bridges and the integrated MOSFET drivers are implemented in the power stage block. A charge pump is designed to supply the gate drivers. Full protection and diagnostics features are implemented in the dedicated blocks.

The digital interface of the device is compatible with both 3.3 V and 5 V microcontrollers, which gives the flexibility on microcontroller selection. The current sense signal presents at IS pin, the microcontroller can read it. The current flowing through each MOSFET is reflected to the IS pin according to different configurations. The IS pin delivers the error flag to the microcontroller. In fault conditions, the fault current $I_{IS(FAULT)}$ flows out of the IS pin. With the external resistance, the current is converted to a voltage level, and post-processed by the microcontroller.

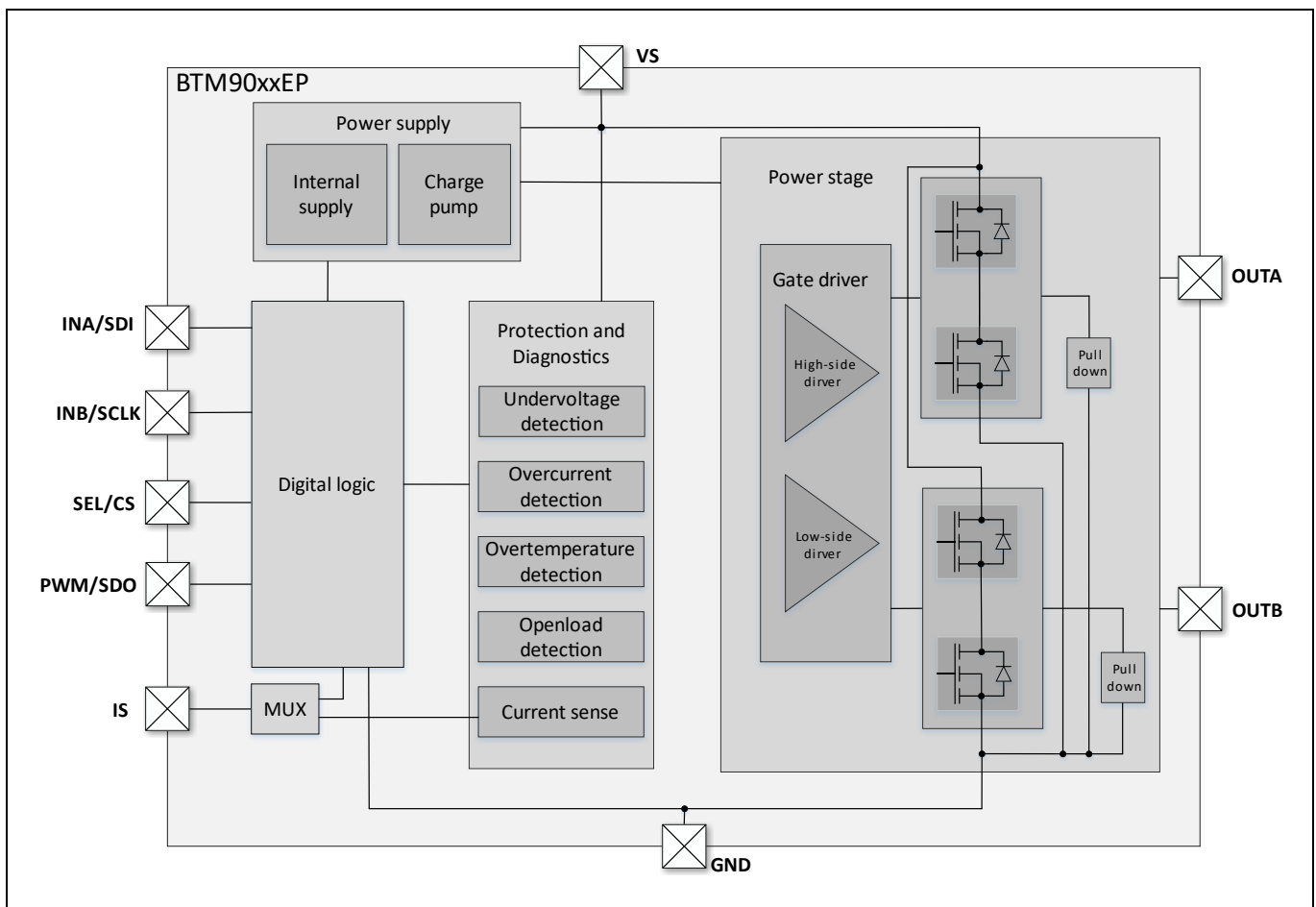

Figure 3 Block diagram of BTM90xxEP

1.4 Pin assignment

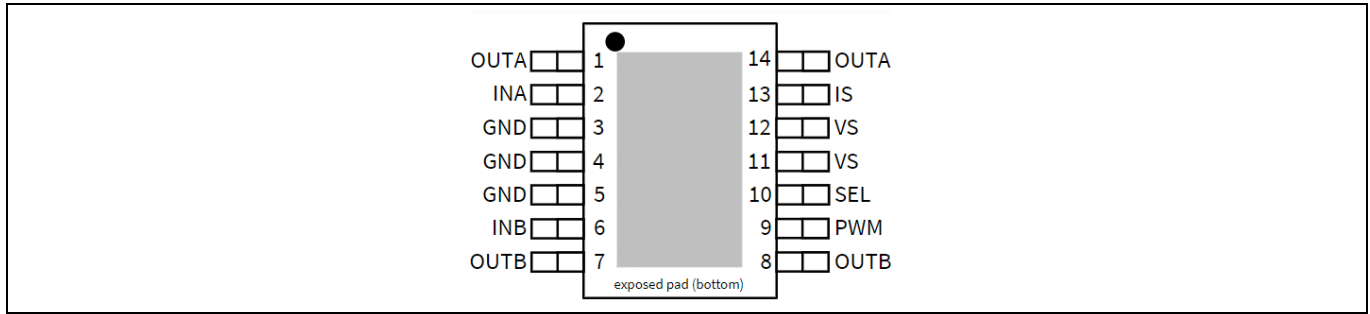

Figure 4 Pin configuration of BTM9010EP/20EP

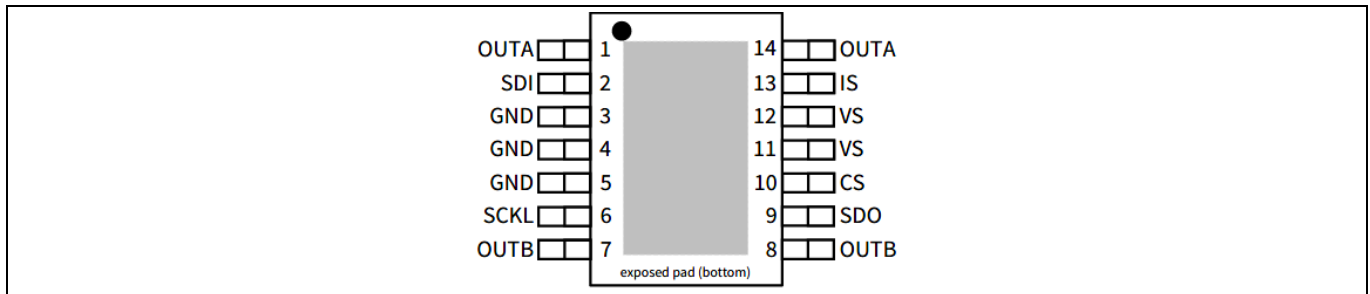

Figure 5 Pin configuration of BTM9011EP/21EP

2 Introduction to the evaluation board

The board is designed to provide a simple, easy-to-use tool familiarize the designers with the MOTIX™ full-bridge ICs BTM90xxEP. Users can design the BDC motor control algorithms and test the designs on the board with **Arduino UNO** or with **uIO-Stick**.

The evaluation board contains three MOTIX™ full-bridge ICs BTM90xxEP devices, an interface to the **Arduino UNO** and a **uIO-Stick** connector. The board design provides the flexibility to designers to test different features of devices. The devices U100 and U200 are connected in daisy-chain configuration. The device U300 can be connected by SPI sequence in daisy-chain configuration, or directly controlled with I/O pins. Refer to **Chapter 2.4** for more details.

The evaluation board works with standard laboratory equipment.

2.1 Block diagram

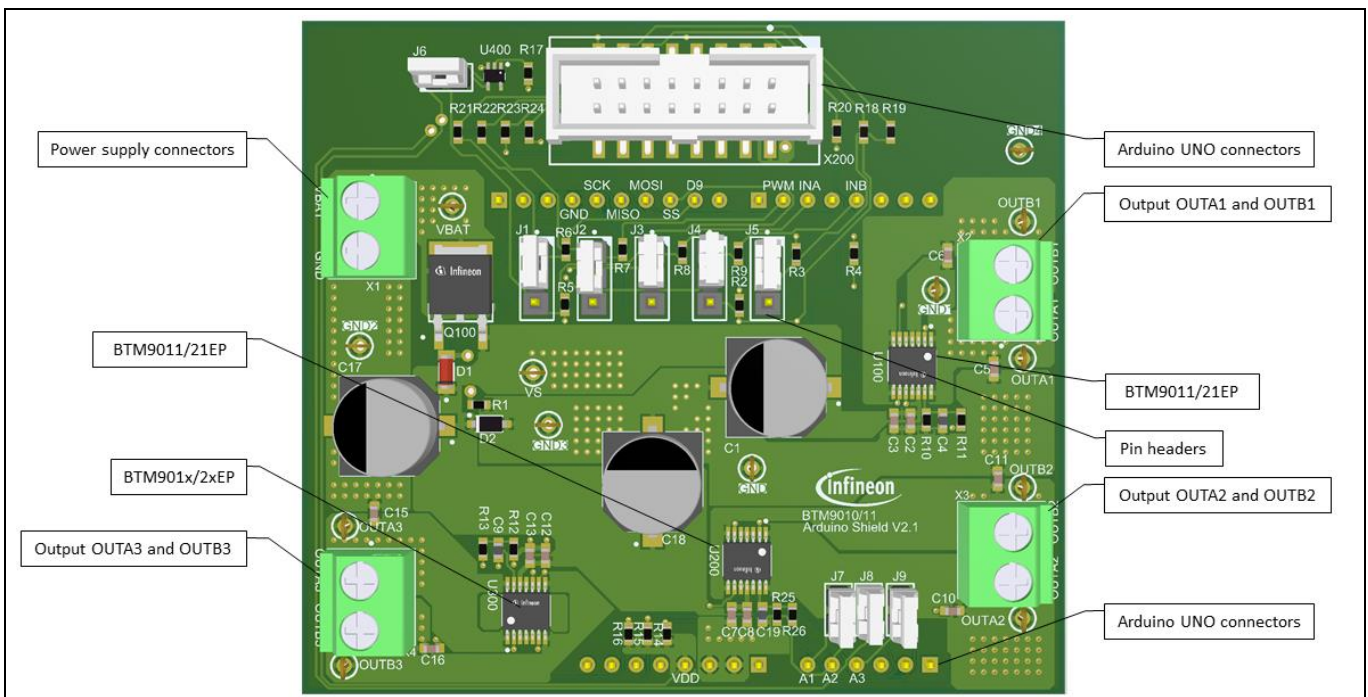

Figure 6 Block diagram

2.2 Main features

The evaluation board has the following features:

- An **Arduino UNO** board or a **uIO-Stick** which is connected to the shield can control the devices with the general IO pins
- Test the performance of the devices with direct input or SPI in daisy-chained configuration
- Brushed DC motor control with or without PWM signal
- 7 – 18 V normal operation voltage (extended operation range: 4.5 V – 40 V)
- Current limitation of min. 10 A (BTM9010/11EP) or min. 20 A (BTM9020/21EP)
- Bi-directional rotation of the brushed DC motor control with the integrated full-bridges and MOSFET drivers
- Capable of high frequency PWM, e.g. 20 kHz using an **Arduino UNO** board
- Adjustable slew rates to optimize the EMC performance
- Drive circuit with logic level inputs
- Status flag diagnosis with current sense capability at IS pin

- Protection schemes, e.g. against overtemperature and overcurrent
- Reverse polarity protection
- Watchdog (valid for BTM9021EP only)

Further comments:

- The size of the DC-link capacitor (C1 in the schematics and C_{DC_LINK} in the application circuit.) at 330 μ F rating should be adjusted based on the applications to stabilize the supply voltage at VS pin. It can be replaced with a capacitor with smaller capacitance when driving less powerful motors

2.3 Technical data

Technical data is specified in the table below. If working with higher currents than the specified maximum ratings, safety measures need to be applied accordingly.

Table 4 Technical data

Parameter	Value
Supply voltage	Typ. 12 V
Supply current	Min. 10 A (BTM901xEP) or min 20 A (BTM902xEP)
PWM frequency	Typ. 20 kHz

Note: The values in [Table 4](#) are specified by design.

2.4 Target applications

The application block diagrams in this chapter provide an overview of the board design and give guidance on how to connect loads to the board. With different devices soldered on the board, users have the possibility to test different features and configurations of the devices, as is shown in [Table 5](#). Configuration 3 and 4 are by default implemented on the evaluation board. To have Configuration 1 and 2, the U300 has to be replaced by BTM9011EP/21EP manually.

Table 5 Application configurations

	U100	U200	U300	Comment
Configuration 1	BTM9011EP	BTM9011EP	BTM9011EP	Three BTM9011EP in daisy-chained SPI control
Configuration 1	BTM9021EP	BTM9021EP	BTM9021EP	Three BTM9021EP in daisy-chained SPI control
Configuration 3	BTM9011EP	BTM9011EP	BTM9010EP	U100 & U200 in daisy-chained SPI configuration, U300 with direct inputs
Configuration 4	BTM9021EP	BTM9021EP	BTM9020EP	U100 & U200 in daisy-chained SPI configuration, U300 with direct inputs

With the boards, users can test both a uni-directional DC motor control in half-bridge configuration and a bi-directional DC motor control in full-bridge configuration. Users can adapt the slew rate through the dedicated input sequence (refer to the datasheet) or through the SPI. BTM90xxEP devices provide the sensed current and error flag at the IS pin.

2.4.1 Debugger

Users can control the board with an [Arduino UNO](#) board or a [uIO-Stick](#):

- Using the [Arduino UNO](#) board: remove the pin header at J6. Only connect headers at J7-J9

- Using the **uIO-Stick**: place the pin header at J6. Connect only one pin header of J7-J9

2.4.2 Application with three BTM90x1EP in daisy-chained SPI control

Figure 7 shows an example with three BTM9011EP/21EP devices connected in daisy-chained configuration reflected in configuration 1 and configuration 2, which is implemented in a DC motor control system. Board 1 and board 2 are designed as shown in the system block diagram.

The SDO pin of the microcontroller is connected to the SDI of the first device. Three devices share the CS, SCLK and A/D pins of the microcontroller. With the daisy-chained configuration, less GPIO pins of the microcontroller are occupied.

Configuration 3 and 4 are the default device setup on the evaluation board.

Configuration 1 and 2 require the following steps:

1. Replace the BTM9010EP/20EP(U300) with BTM9011EP/21EP
2. Place J1 to J5 as shown in **Figure 8**

For more details of SPI of BTM9011EP/21EP, refer to the datasheets of BTM9011EP/21EP.

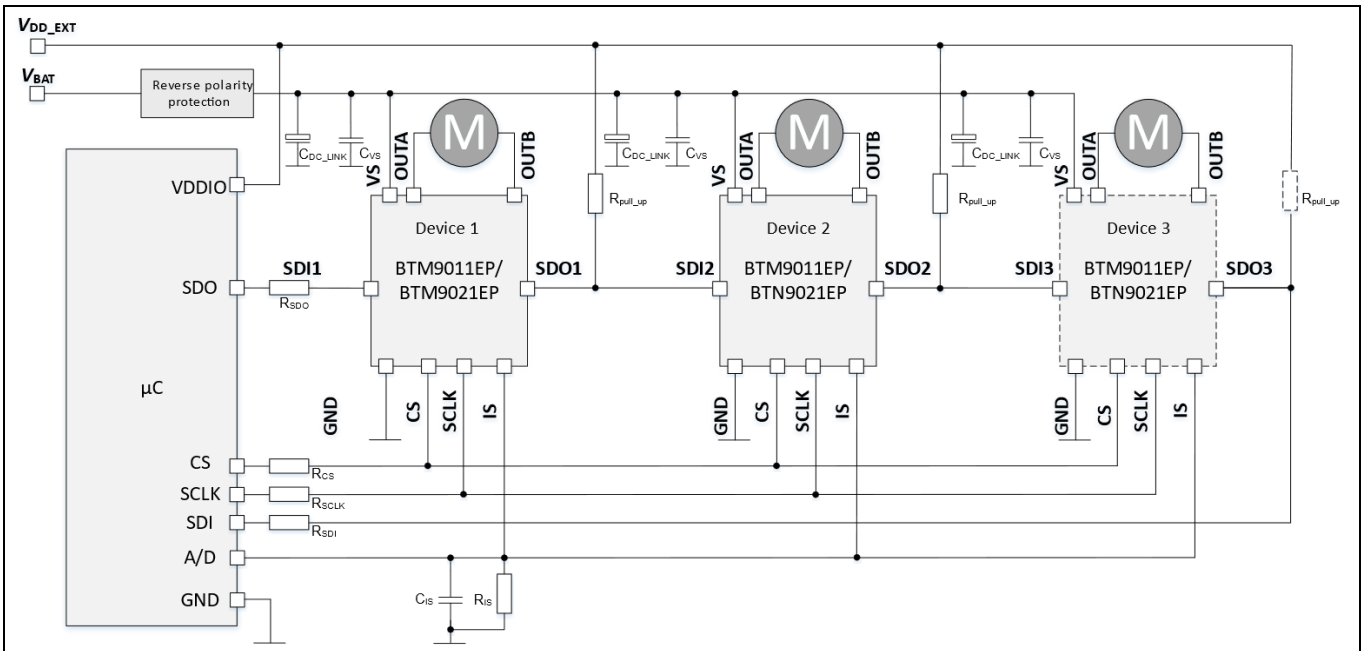

Figure 7 Example of application with BTM9011EP/21EP in daisy-chain SPI configuration

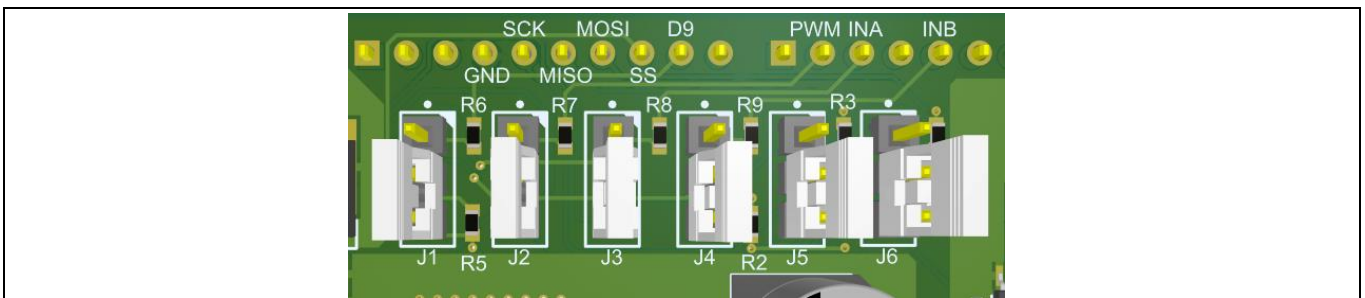

Figure 8 J1 – J6 pin header placement

2.4.3 Application with daisy-chain SPI configuration and direct input

Figure 9 shows the configuration 3 and 4 (default configuration), where two BTM9011EP/21EP devices connect in daisy-chain configuration and the microcontroller directly controls one BTM9010EP/20EP. With configuration 3 and 4, users can directly control one SPI variant BTM9010EP/20EP and the two pieces of the SPI variant BTM9011EP/21EP.

The SDO pin of the microcontroller connects to the SDI of the first device. Two devices share the CS, SCLK and A/D pins of the microcontroller. The I/O pins of the microcontroller directly control a third device.

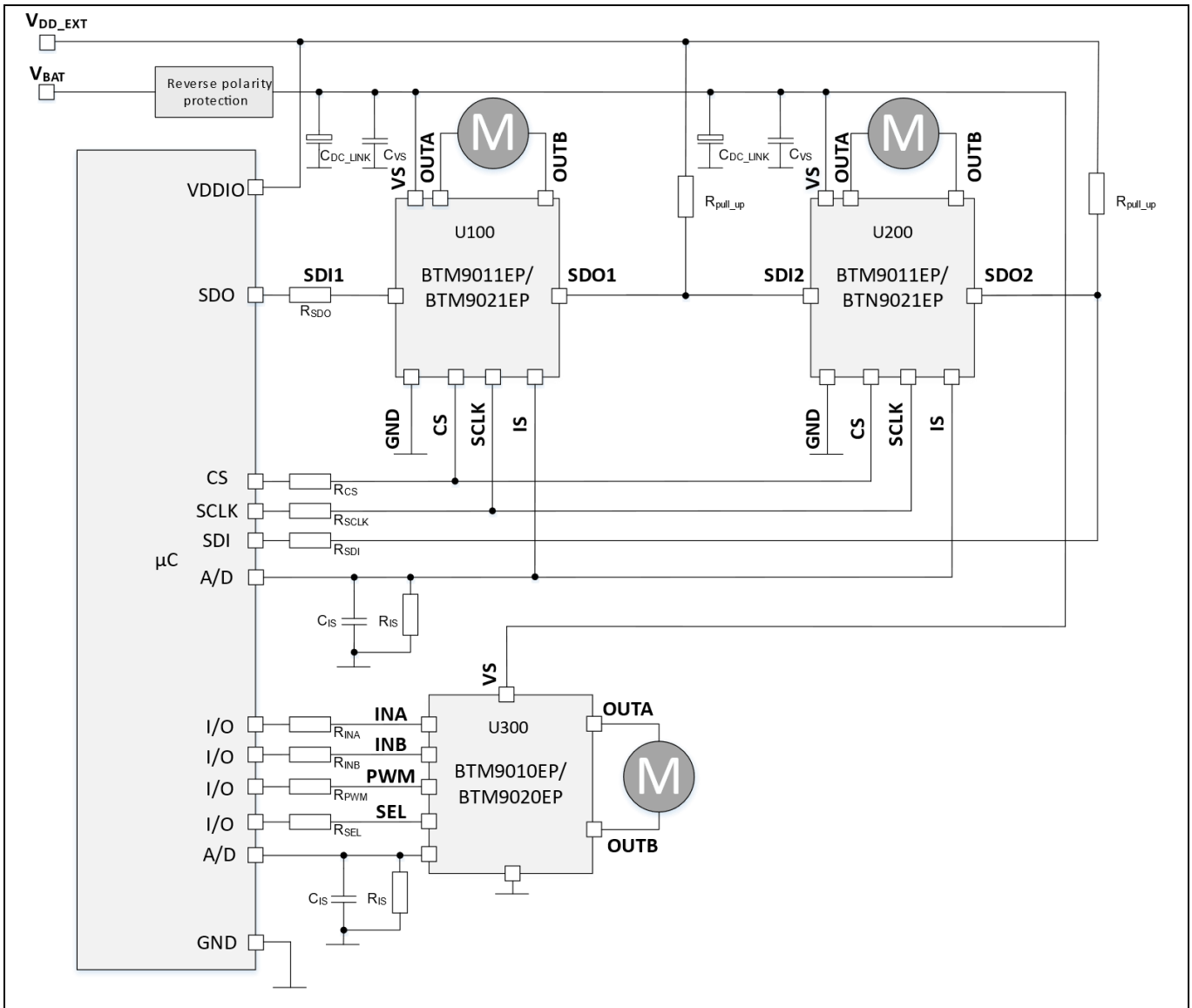

Figure 9 Example of application with daisy-chained SPI configuration and direct input control

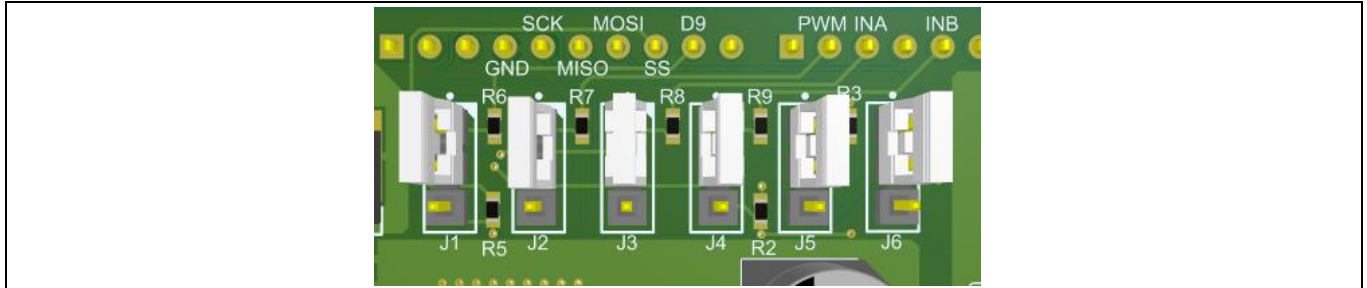

Figure 10 J1 – J6 pin header placement

For more details of SPI and direct input settings of BTM90xxEP, refer to the datasheets.

3 System and functional description

For the purpose of evaluation of DC motor control, discrete components are populated on board. They can be adapted to the dedicated motor control applications.

3.1 Board information

Find detailed information on the board in the tables below.

Table 6 **Devices**

Designator	Description
U100, U200, U300	MOTIX™ full-bridge ICs BTM90xxEP
Q100, D1, R1	Reverse battery protection circuit
C1, C17, C18	DC-link capacitors

Table 7 **Connectors**

Function	Designator	Description
VBAT, GND	X1	Screw connector for power supply and ground
OUTA1-3, OUTB1-3	X2, X3, X4	Output screw connectors for MOTIX™ full-bridge ICs BTM90xxEP

Table 8 **Test point**

Function	Designator	Description
VBAT	VBAT	Test point to measure supply voltage
VS	VS	Test point to measure supply voltage of MOTIX™ full-bridge ICs BTM90xxEP
OUTA1-3, OUTB1-3	OUTA1-3, OUTB1-3	Test point to measure output of MOTIX™ full-bridge ICs BTM90xxEP
GND	GND, GND1-4	Test points to connect to ground

Table 9 **Jumpers**

Designator	Description
J1 – J5	By default, all jumpers are placed at the two pins close to the designators, and all three devices are in daisy-chained SPI connection. Move all jumpers to the two pins away from the designators to realize two devices in daisy-chained connection and one directly input control
J6	Jumper to be removed to disconnect the uIO-Stick signal when an Arduino UNO board is controlling the board
J7 – J9	Jumper to select which sensed current should be sent to the uIO-Stick . When an Arduino UNO board is controlling the board, all three IS signal can be monitored with the I/O pins

Table 10 Pins connectors to Arduino UNO

Designator	Connected to Arduino pin	Connected to BTM90xxEP pin	Description
VDD	+ 5 V	SDO	Logic input of BTM90xxEP from Arduino UNO
A1, A2, A3	D14, A15, D16	IS	Analog input of Arduino UNO for current sensing and error flag monitoring
SCK	D13	SCLK	Serial clock input with internal pull down
MISO	D12	SDO	Serial data output
MOSI	D11	SDI	Serial data input with internal pull down
SS	D10	CS	Chip select input with internal pull down
D9	D9	SEL	Current sense selection pin
PWM	D6	PWM	PWM input of the low side MOSFET during the on phase
INA	D5	INA	Input of half-bridge A
INB	D3	INB	Input of half-bridge B

3.2 Arduino UNO interface

MOTIX™ full-bridge ICs BTM90xxEP can be configured using software through the **Arduino UNO** interface. Connect the board to an **Arduino UNO** board at the pin headers X101, X102, X103 and X104.

3.3 uIO-Stick interface

MOTIX™ full-bridge ICs BTM90xxEP can be configured using software through the **uIO-Stick**. Connect **uIO-Stick** at the connector X200.

4 Design files

4.1 Schematics

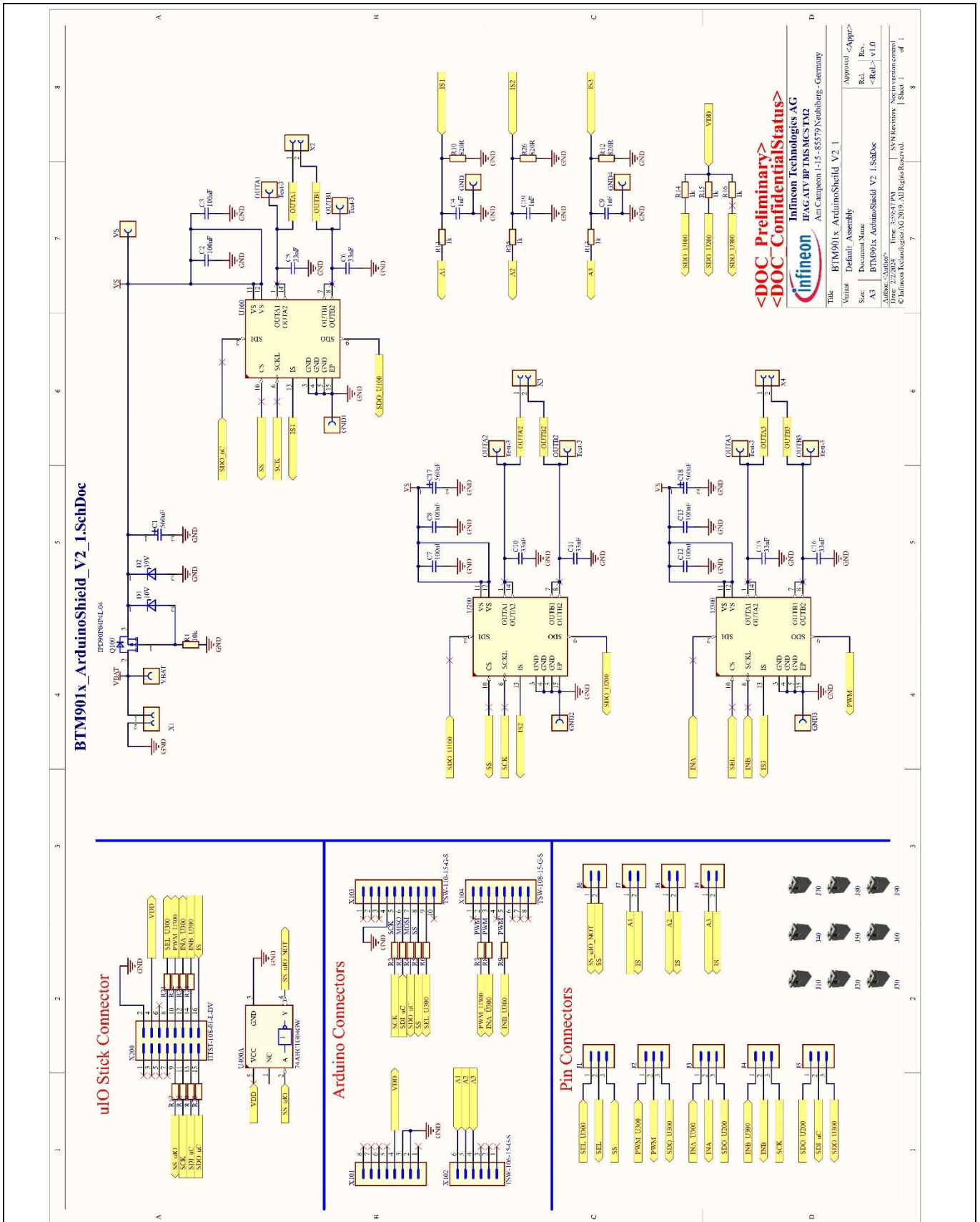

Figure 11 MOTIX™ full-bridge ICs BTM901xxEP Arduino Shield schematics

4.2 Layout

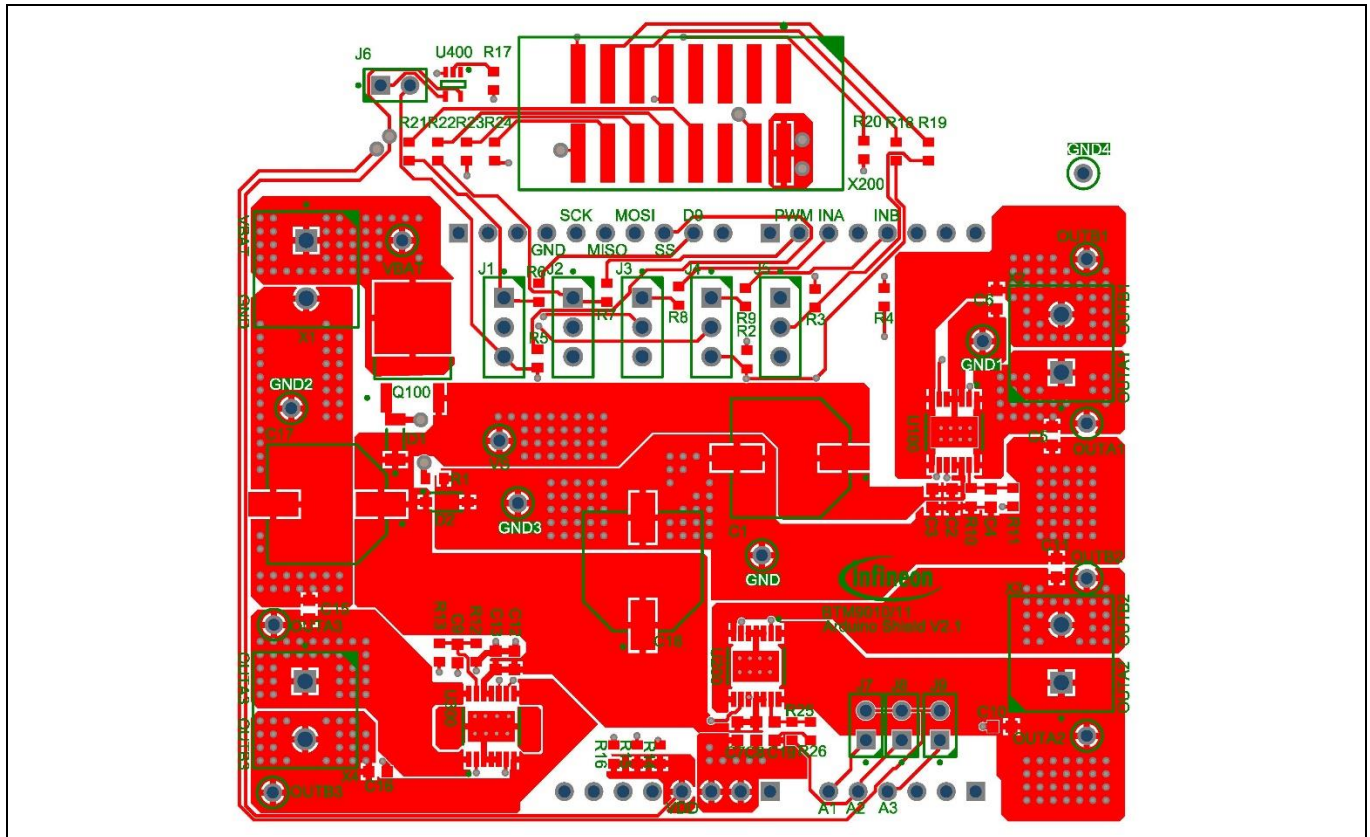

Figure 12 MOTIX™ full-bridge ICs BTM901xxEP Arduino Shield layer 1 (top layer)

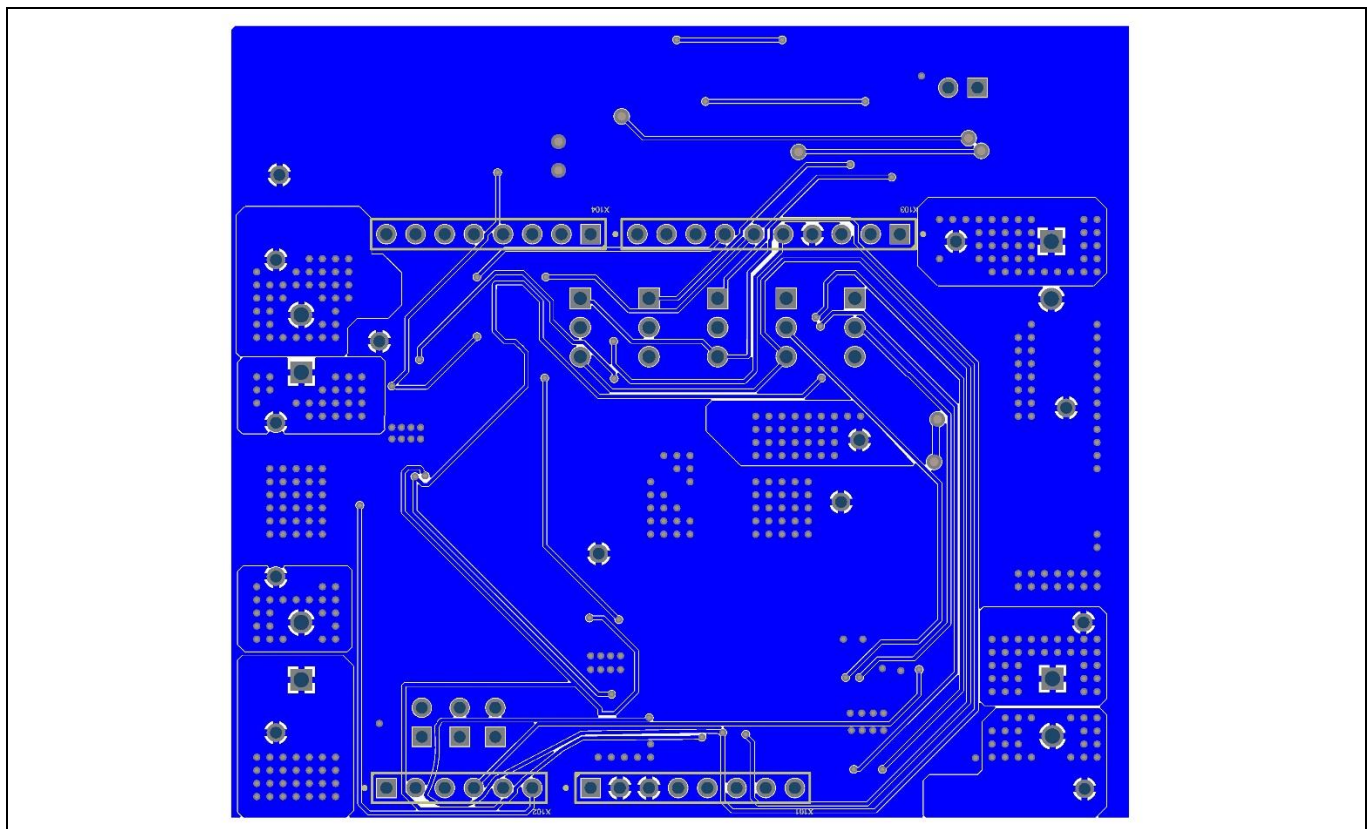

Figure 13 MOTIX™ full-bridge ICs BTM901xxEP Arduino Shield layer 2 (bottom layer)

4.3 Bill of material

Table 11 BOM of MOTIX™ full-bridge ICs BTM90xxEP Arduino Shield

Designator	Description	Quantity	Footprint
C1, C17, C18	CAP / ELCO / 560uF / 35V / 20% / - / -55°C to 105°C / 10.30mm L X 10.30mm W X 10.50mm H / SMD / -	3	CAPAE1030X1050N
C2, C3, C7, C8, C12, C13	CAP / CERA / 100nF / 50V / 10% / X7R (EIA) / -55°C to 125°C / 0603(1608) / SMD / -, CAP / CERA / 100nF / 50V / 5% / X7R (EIA) / -55°C to 125°C / 0603(1608) / SMD / -	6	CAPC1608X90N
C4, C9, C19	CAP / CERA / 1nF / 50V / 1% / COG (EIA) / NP0 / -55°C to 125°C / 0603(1608) / SMD / -	3	CAPC1608X87N
C5, C6, C10, C11, C15, C16	CAP / CERA / 33nF / 50V / 10% / X7R (EIA) / -55°C to 125°C / 0603(1608) / SMD / -	6	CAPC1608X90N
D1	Voltage regulator diode, 10V	1	DIOMELF3515N-2
D2	Zener Voltage Regulator, 500mW, 39V	1	SOD3716X135N
GND, GND1, GND2, GND3, GND4, OUTA1, OUTA2, OUTA3, OUTB1, OUTB2, OUTB3, VBAT, VS	Test Pin PCB, 1mm, Gold Plated Copper	13	CON-THT-TP-TEST-3
J1, J2, J3, J4, J5	Through hole .025 SQ Post Header, 2.54mm pitch, 3 pin, vertical, single row	5	CON-THT-2.54-3-1-8.38
J6, J7, J8; J9	'2.54mm Pitch Vertical PC Tail Male Connector	4	CON-M-THT-M20-9770246
J10, J20, J30, J40, J50, J60, J70, J80, J90	Jumper, 1x2-Positions, Pitch 2,54mm, Body 5,08x2,54mm, black, Au, with handle	9	CON-F-SOC-JMP-254-1X2-BK-G-H
Q100	OptiMOS-P2 P-Channel Enhancement Power-Transistor,-40V	1	TO228P998X235-3N
R1	RES / STD / 10k / 100mW / 1% / 100ppm/K / -55°C to 155°C / 0603(1608) / SMD / -	1	RESC1608X55N-1
R2, R3, R4, R5, R6, R7, R8, R9, R11, R13, R14, R15, R16, R17, R18, R19, R20, R21, R22, R23, R24, R25	RES / STD / 1k / 100mW / 1% / 100ppm/K / -55°C to 155°C / 0603(1608) / SMD / -	22	RESC1608X55N-1
R10, R12, R16	RES / STD / 820R / 100mW / 1% / 100ppm/K / -55°C to 155°C / 0603(1608) / SMD / -	3	RESC1608X55N-1
U100, U200, U300	MOTIX™ full-bridge ICs BTM90xxEP	3	SOP65P600X115-15N-V
U400	Inverter	1	SOT65P212X110-5N
X1, X2, X3, X4	Screw Compact Terminal Block, Nominal current 32A, Nominal Voltage 400V, 2 pin 5mm Pitch	4	CON-TER-THT-1935776
X101, X104	Through-Hole .025 SQ Post Header, 2.54mm pitch, 8 pins, Vertical, Single row, 500V	2	CON-M-THT-TSW-108-15-G-S

Designator	Description	Quantity	Footprint
X102	Through-Hole .025 SQ Post Header, 2.54mm pitch, 6 pins, Vertical, Single row, 500V	1	CON-M-THT-TSW-108-15-G-S
X103	Through-Hole .025 SQ Post Header, 2.54mm pitch, 10 pins, Vertical, Single row, 500V	1	CON-M-THT-TSW-108-15-G-S
X200	SMT, .025 Shrouded SQ POST IDC Headers, 2.54mm pitch, 16-pin Vertical, Double row	1	CON-M-SMD-HTST-108-01-L-DV

5 Getting started

5.1 Getting started using Arduino UNO board

5.1.1 Hardware

Follow the instructions below to get started:

- Choose brushed DC motors considering:
 - The normal operation voltage of the board: 7 – 18 V
 - The extended operation voltage of the board: 4.5 - 40 V
- Remove the pin header at J6. Check other pin headers as instructed
- Connect the board to **Arduino UNO** through the pin headers X101, X102, X103 and X104
- Connect the **Arduino UNO** to the PC
- Connect the motors to the output ports OUTxx
 - For bi-directional applications in full-bridge configuration: connect the motor between OUTAx and OUTBx
 - For uni-directional applications in half-bridge configuration: connect the motor to OUTAx/OUTBx and either GND/Vbat
- Connect a DC power supply to the board (VBAT pin, GND pin), and turn on the power supply

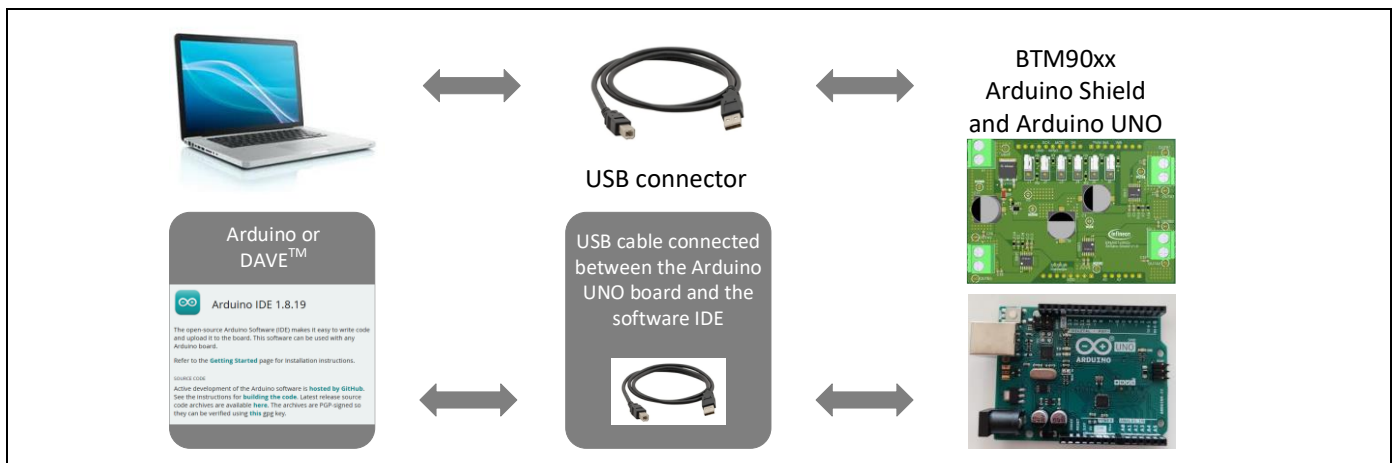

Figure 14 Hardware set up of the Motor Control Shield

5.1.2 Software

To program with the **Arduino UNO**, please follow the steps below:

- Download and install **Arduino IDE**
- Connect the **Arduino UNO** board to the laptop with a micro-USB cable
- Start **Arduino IDE**
- Create a new script or open an existing script as shown below
- Compile the script
- Execute the code

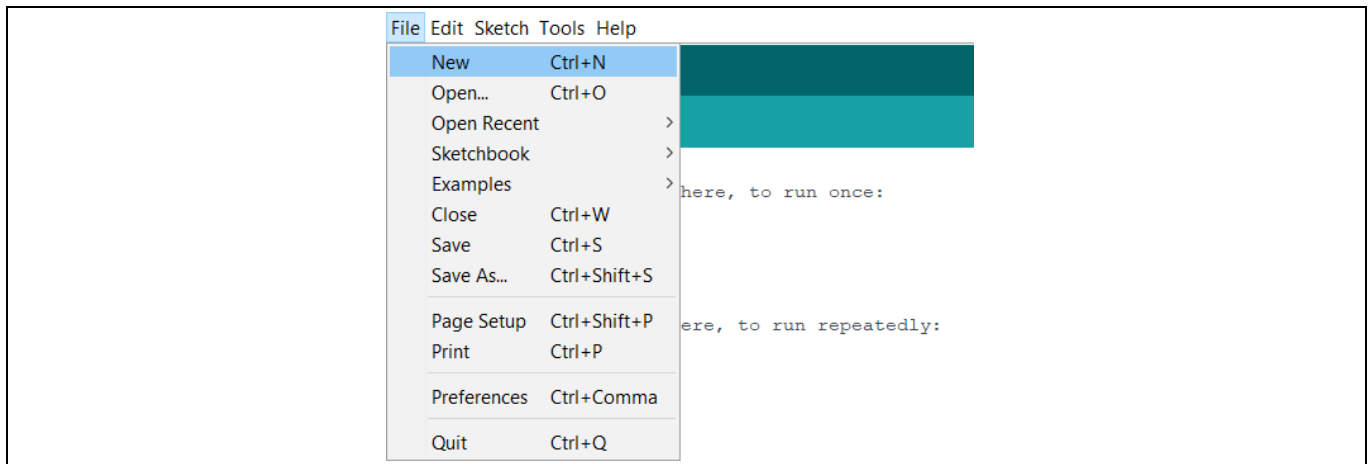

Figure 15 Create and open script files in Arduino IDE

5.2 Getting started using uIO-Stick

5.2.1 Hardware

Follow the instructions below to get started:

- Choose brushed DC motors considering:
 - The normal operation voltage of the board: 7 – 18 V
 - The extended operation voltage of the board: 4.5 - 40 V
- Set pin header J6 - J9 as instructed. Check other pin headers as instructed
- Connect the **uIO-Stick** to the board with the connector X200
- Attach the **uIO-Stick** to the CP
- Connect the motors to the output ports OUTxx
 - For bi-directional applications in full-bridge configuration: connect the motor between OUTAx and OUTBx
 - For uni-directional applications in half-bridge configuration: connect the motor to OUTAx/OUTBx and either GND/Vbat
- Connect a DC power supply to the board (VBAT pin, GND pin), and turn on the power supply

5.2.2 Software

To control the board with the **uIO-Stick**, please follow the steps below:

- Download and install the **Infineon Developer Center Launcher**
- Search, install and start **Config Wizard for MOTIX Full Bridge ICs** in the **Infineon Developer Center Launcher**
- Select the board configuration in the tool
- Configure the board in the tool

For more details about the tool, refer to the user guide.

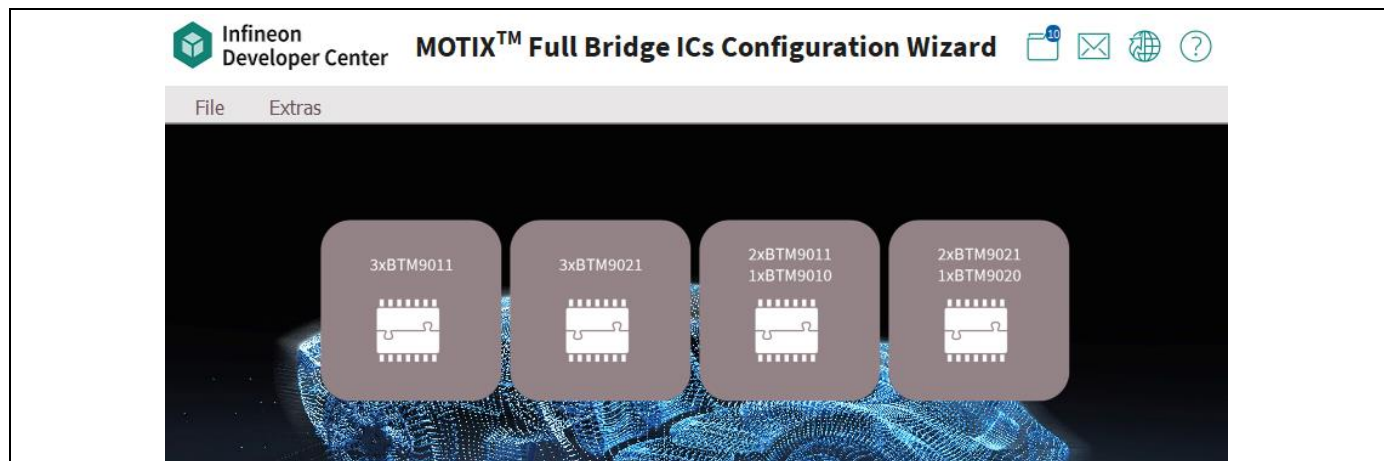

Figure 16 Board selection view in Config Wizard

Revision history

Document version	Date of release	Description of changes
1.10	2024-06-18	<ul style="list-style-type: none">• Update according to new board design• Editorial changes
1.00	2023-10-13	<ul style="list-style-type: none">• Initial Release

Trademarks

All referenced product or service names and trademarks are the property of their respective owners.

Edition 2024-06-18

Published by

Infineon Technologies AG
81726 Munich, Germany

© 2024 Infineon Technologies AG.
All Rights Reserved.

Do you have a question about this document?

Email: erratum@infineon.com

Document reference
Z8F80497277

IMPORTANT NOTICE

The information contained in this application note is given as a hint for the implementation of the product only and shall in no event be regarded as a description or warranty of a certain functionality, condition or quality of the product. Before implementation of the product, the recipient of this application note must verify any function and other technical information given herein in the real application. Infineon Technologies hereby disclaims any and all warranties and liabilities of any kind (including without limitation warranties of non-infringement of intellectual property rights of any third party) with respect to any and all information given in this application note.

The data contained in this document is exclusively intended for technically trained staff. It is the responsibility of customer's technical departments to evaluate the suitability of the product for the intended application and the completeness of the product information given in this document with respect to such application.

For further information on the product, technology delivery terms and conditions and prices please contact your nearest Infineon Technologies office (www.infineon.com).

WARNINGS

Due to technical requirements products may contain dangerous substances. For information on the types in question please contact your nearest Infineon Technologies office.

Except as otherwise explicitly approved by Infineon Technologies in a written document signed by authorized representatives of Infineon Technologies, Infineon Technologies' products may not be used in any applications where a failure of the product or any consequences of the use thereof can reasonably be expected to result in personal injury.