

2Mb EXCELON™ LP Ferroelectric RAM (F-RAM)

WEL enabled, Serial (SPI), 256K × 8, industrial

Features

- 2-Mbit ferroelectric random access memory (F-RAM) logically organized as 256K × 8
 - Virtually unlimited endurance of 1000 trillion (10^{15}) read/write cycles
 - 151-year data retention (see **“Data retention and endurance”** on page 23)
 - Infineon instant non-volatile write technology
 - Advanced high-reliability ferroelectric process
- Fast SPI (FSPI)
 - Up to 50 MHz frequency
 - Supports SPI mode 0 (0, 0) and mode 3 (1, 1)
- Sophisticated write protection scheme
 - Hardware protection using the Write Protect (\overline{WP}) pin
 - Software block protection for 1/4, 1/2, or entire array
- Device ID and serial number
 - Device ID contains manufacturer ID and product ID
 - Unique ID
 - Serial number
- Dedicated 256-byte special sector F-RAM
 - Dedicated special sector write and read
 - Stored content can survive up to three standard reflow soldering cycles
- Low-power consumption
 - 2.4 mA (typ) active current at 40 MHz
 - 2.3 μ A (typ) standby current
 - 0.70 μ A (typ) deep power down mode current
 - 0.1 μ A (typ) hibernate mode current
- Low-voltage operation
 - CY15B102QM: $V_{DD} = 1.8$ V to 3.6 V
- Industrial operating temperature: -40°C to $+85^{\circ}\text{C}$
- Package
 - 8-pin small outline integrated circuit (SOIC) package
- Restriction of hazardous substances (RoHS) compliant

Functional description

The EXCELON™ LP CY15B102QM is a low power, 2-Mbit nonvolatile memory employing an advanced ferroelectric process. A ferroelectric random access memory or F-RAM is nonvolatile and performs reads and writes similar to a RAM. It provides reliable data retention for 151 years while eliminating the complexities, overhead, and system-level reliability problems caused by serial flash, EEPROM, and other nonvolatile memories.

Unlike serial flash and EEPROM, the CY15B102QM performs write operations at bus speed. No write delays are incurred. Data is written to the memory array immediately after each byte is successfully transferred to the device. The next bus cycle can commence without the need for data polling. In addition, the product offers substantial write endurance compared to other nonvolatile memories. The CY15B102QM is capable of supporting 10^{15} read/write cycles, or 1000 million times more write cycles than EEPROM.

These capabilities make the CY15B102QM ideal for nonvolatile memory applications, requiring frequent or rapid writes. Examples range from data collection, where the number of write cycles may be critical, to demanding industrial controls where the long write time of serial flash or EEPROM can cause data loss.

The CY15B102QM provides substantial benefits to users of serial EEPROM or flash as a hardware drop-in replacement. The CY15B102QM uses the high-speed SPI bus, which enhances the high-speed write capability of F-RAM technology. The device incorporates a read-only Device ID and Unique ID features, which allow the host to determine the manufacturer, product density, product revision, and unique ID for each part. The device also provides a writable, 8-byte serial number registers, which can be used to identify a specific board or a system.

Logic block diagram

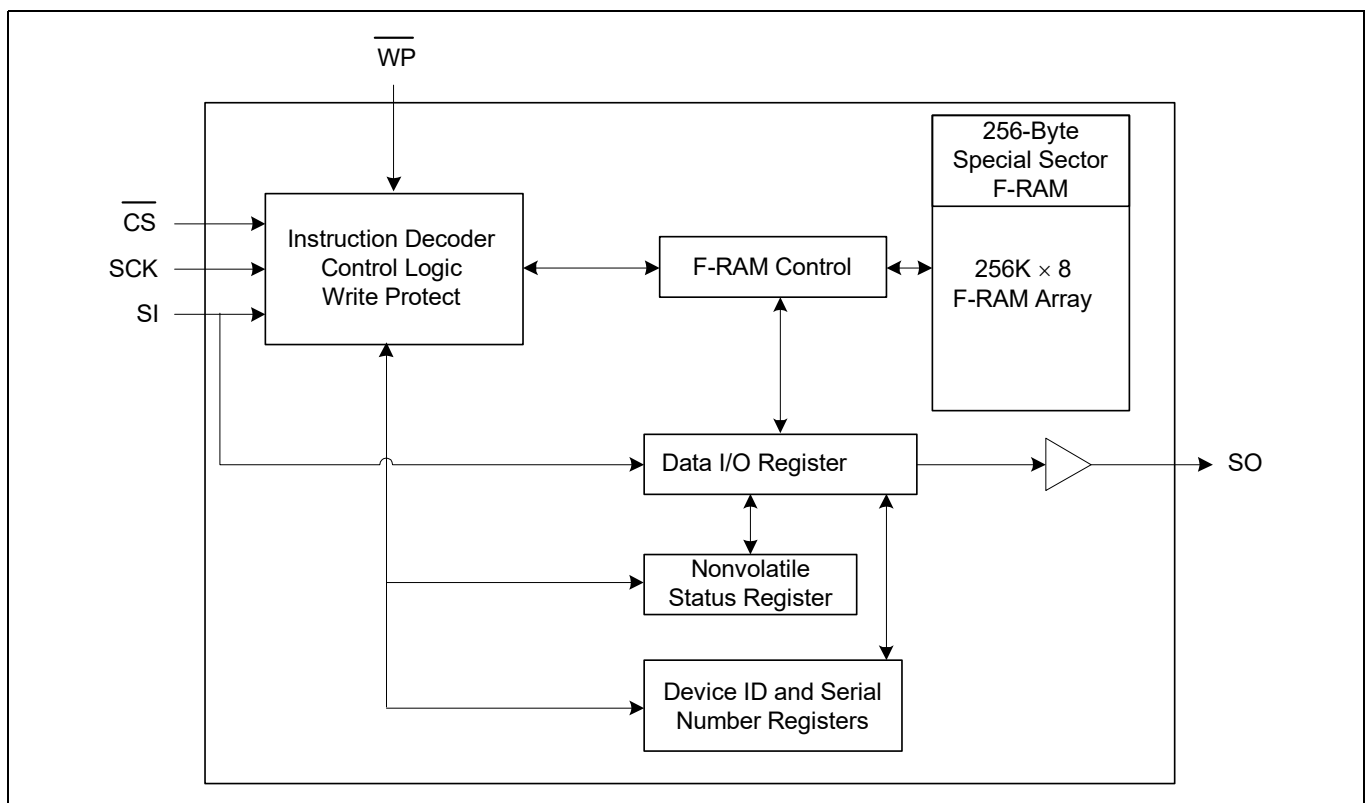

Table of contents

Features	1
Functional description	2
Logic block diagram	2
Table of contents	3
1 Pinout	4
2 Pin definitions	5
3 Functional overview	6
3.1 Memory architecture	6
3.2 SPI bus	6
3.2.1 SPI overview	6
3.3 Terms used in SPI protocol	7
3.3.1 SPI master	7
3.3.2 SPI slave	7
3.3.3 Chip select (CS)	7
3.3.4 Serial clock (SCK)	7
3.3.5 Data transmission (SI/SO)	7
3.3.6 Most significant bit (MSb)	8
3.3.7 Serial Opcode	8
3.3.8 Invalid Opcode	8
3.3.9 Status Register	8
3.4 SPI modes	9
3.5 Power-up to first access	9
4 Functional description	10
4.1 Command structure	10
4.1.1 Register access commands	12
4.1.2 Memory operation	12
4.1.3 Memory write operation commands	13
4.1.4 Memory read operation commands	14
4.1.5 Special sector memory access commands	15
4.1.6 Identification and serial number commands	16
4.1.7 Low power mode commands	18
5 Maximum ratings	20
6 Operating range	21
7 DC electrical characteristics	22
8 Data retention and endurance	23
9 Capacitance	24
10 Thermal resistance	25
11 AC test conditions	26
12 AC switching characteristics	27
13 Power cycle timing	29
14 Ordering information	30
15 Package diagram	31
16 Acronyms	32
17 Document conventions	33
17.1 Units of measure	33
Revision history	34

Pinout

1 Pinout

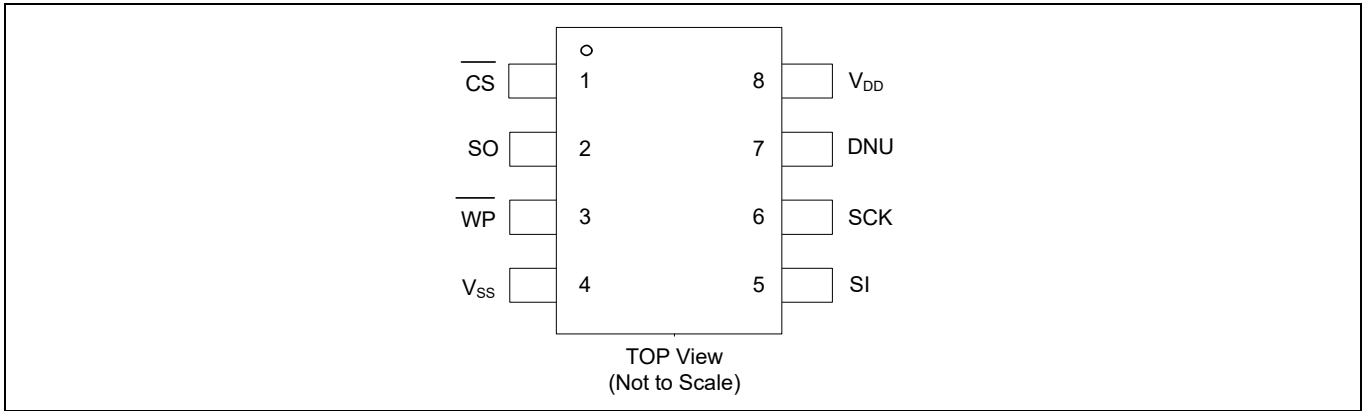

Figure 1 8-pin SOIC pinout

2 Pin definitions

Table 1 Pin definitions

Pin name	I/O type	Description
$\overline{\text{CS}}$	Input	Chip Select. This active LOW input activates the device. When HIGH, the device enters low-power standby mode, ignores other inputs, and the output is tristated. When LOW, the device internally activates the SCK signal. A falling edge on $\overline{\text{CS}}$ must occur before every opcode.
SCK	Input	Serial Clock. All I/O activity is synchronized to the serial clock. Inputs are latched on the rising edge and outputs occur on the falling edge of the serial clock. The clock frequency may be any value between 0 MHz and 50 MHz and may be interrupted at any time due to its synchronous behavior.
SI ^[1]	Input	Serial Input. All data is input to the device on this pin. The pin is sampled on the rising edge of SCK and is ignored at other times. It should always be driven to a valid logic level to meet the power (I_{DD}) specifications.
SO ^[1]	Output	Serial Output. This is the data output pin. It is driven during a read and remains tristated at all other times. Data transitions are driven on the falling edge of the serial clock SCK.
$\overline{\text{WP}}$	Input	Write Protect. This Active LOW pin prevents write operation to the Status Register when WPEN bit in the Status Register is set to '1'. This is critical because other write protection features are controlled through the Status Register. A complete explanation of write protection is provided in Table 3 and Table 6 . This pin must be tied to V_{DD} if not used.
DNU	Do Not Use	Do Not Use. Either leave this pin floating (not connected on the board) or tie to V_{DD} .
V_{SS}	Power supply	Ground for the device. Must be connected to the ground of the system.
V_{DD}	Power supply	Power supply input to the device.

Note

1. SI may be connected to SO for a single pin data interface.

3 Functional overview

The CY15B102QM is a serial F-RAM memory. The memory array is logically organized as 262,144 × 8 bits and is accessed using an industry-standard SPI bus. The functional operation of the F-RAM is similar to serial flash and serial EEPROMs. The major difference between the CY15B102QM and a serial flash or EEPROM with the same pinout is the F-RAM's superior write performance, high endurance, and low power consumption.

3.1 Memory architecture

When accessing the CY15B102QM, the user addresses 256K locations of eight data bits each. These eight data bits are shifted in or out serially. The addresses are accessed using the SPI protocol, which includes a chip select (to permit multiple devices on the bus), an opcode, and a three-byte address. The upper five bits of the address range are 'don't care' values. The complete address of 18 bits specifies each byte address uniquely.

Most functions of the CY15B102QM are either controlled by the SPI interface or handled by on-board circuitry. The access time for the memory operation is essentially zero, beyond the time needed for the serial protocol. That is, the memory is read or written at the speed of the SPI bus. Unlike a serial flash or EEPROM, it is not necessary to poll the device for a ready condition because writes occur at bus speed. By the time a new bus transaction can be shifted into the device, a write operation is complete. This is explained in more detail in the interface section.

3.2 SPI bus

The CY15B102QM is an SPI slave device and operates at speeds of up to 50 MHz. This high-speed serial bus provides high-performance serial communication to an SPI master. Many common microcontrollers have hardware SPI ports allowing a direct interface. It is simple to emulate the port using ordinary port pins for microcontrollers that do not have this feature. The CY15B102QM operates in SPI Modes 0 and 3.

3.2.1 SPI overview

The SPI is a four-pin interface with Chip Select (\overline{CS}), Serial Input (SI), Serial Output (SO), and Serial Clock (SCK) pins.

The SPI is a synchronous serial interface, which uses clock and data pins for memory access and supports multiple devices on the data bus. A device on the SPI bus is activated using the \overline{CS} pin.

The relationship between chip select, clock, and data is dictated by the SPI mode. This device supports SPI modes 0 and 3. In both of these modes, data is clocked into the F-RAM on the rising edge of SCK starting from the first rising edge after \overline{CS} goes active.

The SPI protocol is controlled by opcodes. These opcodes specify the commands from the bus master to the slave device. After \overline{CS} is activated, the first byte transferred from the bus master is the opcode. Following the opcode, any addresses and data are then transferred. The \overline{CS} must go inactive after an operation is complete and before a new opcode can be issued.

3.3 Terms used in SPI protocol

The commonly used terms in the SPI protocol are as follows:

3.3.1 SPI master

The SPI master device controls the operations on the SPI bus. An SPI bus may have only one master with one or more slave devices. All the slaves share the same SPI bus lines and the master may select any of the slave devices using the CS pin. All of the operations must be initiated by the master activating a slave device by pulling the CS pin of the slave LOW. The master also generates the SCK and all the data transmission on SI and SO lines are synchronized with this clock.

3.3.2 SPI slave

The SPI slave device is activated by the master through the Chip Select line. A slave device gets the SCK as an input from the SPI master and all the communication is synchronized with this clock. An SPI slave never initiates a communication on the SPI bus and acts only on the instruction from the master.

The CY15B102QM operates as an SPI slave and may share the SPI bus with other SPI slave devices.

3.3.3 Chip select ($\overline{\text{CS}}$)

To select any slave device, the master needs to pull down the corresponding $\overline{\text{CS}}$ pin. Any instruction can be issued to a slave device only while the $\overline{\text{CS}}$ pin is LOW. When the device is not selected, data through the SI pin is ignored and the serial output pin (SO) remains in a high-impedance state.

Note: A new instruction must begin with the falling edge of $\overline{\text{CS}}$. Therefore, only one opcode can be issued for each active Chip Select cycle.

3.3.4 Serial clock (SCK)

The serial clock is generated by the SPI master and the communication is synchronized with this clock after $\overline{\text{CS}}$ goes LOW.

The CY15B102QM supports SPI modes 0 and 3 for data communication. In both of these modes, the inputs are latched by the slave device on the rising edge of SCK and outputs are issued on the falling edge. Therefore, the first rising edge of SCK signifies the arrival of the first Most Significant Bit (MSb) of an SPI instruction on the SI pin. Further, all data inputs and outputs are synchronized with SCK.

3.3.5 Data transmission (SI/SO)

The SPI data bus consists of two lines, SI and SO, for serial data communication. SI is also referred to as Master Out Slave In (MOSI) and SO is referred to as Master In Slave Out (MISO). The master issues instructions to the slave through the SI pin, while the slave responds through the SO pin. Multiple slave devices may share the SI and SO lines as described earlier.

The CY15B102QM has two separate pins for SI and SO, which can be connected with the master as shown in **Figure 2**. For a microcontroller that has no dedicated SPI bus, a general-purpose port may be used. To reduce hardware resources on the controller, it is possible to connect the two data pins (SI, SO) together and tie off (HIGH) the $\overline{\text{WP}}$ pin. **Figure 3** shows such a configuration, which uses only three pins.

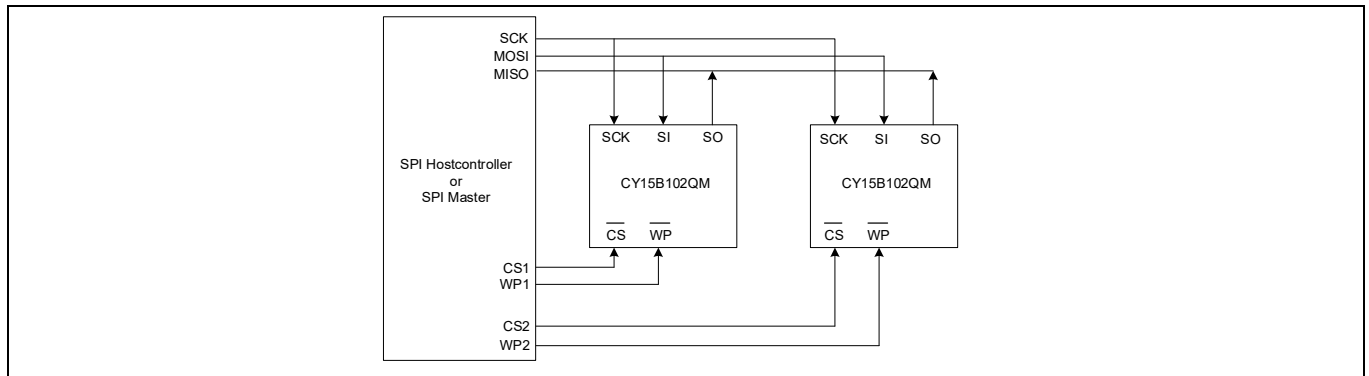

Figure 2 System configuration with SPI port

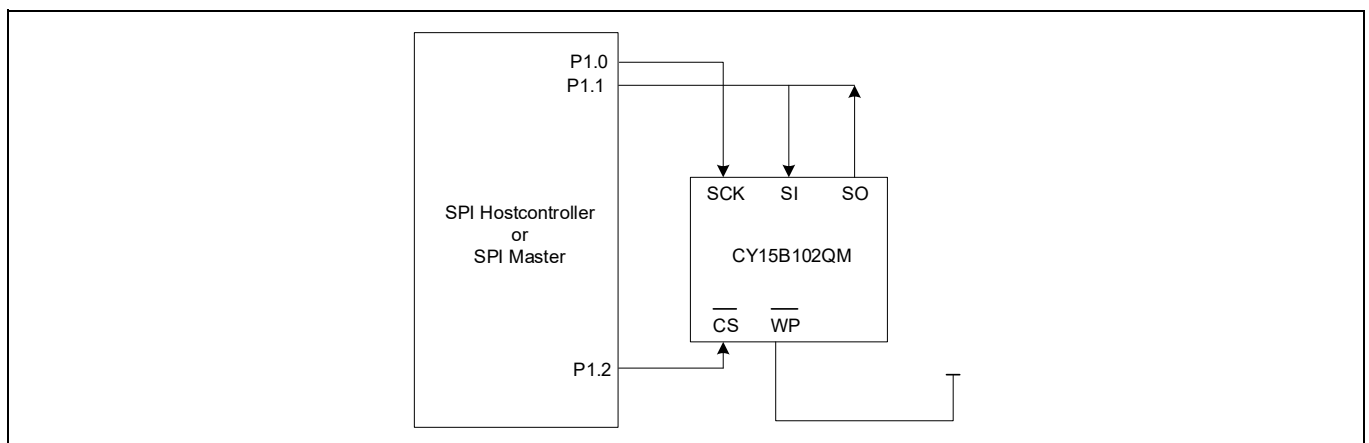

Figure 3 System configuration without SPI port

3.3.6 Most significant bit (MSb)

The SPI protocol requires that the first bit to be transmitted is the MSb. This is valid for both address and data transmission.

The 2-Mbit serial F-RAM requires a 3-byte address for any read or write operation. Because the address is only 18 bits, the first six bits, which are fed in are ignored by the device. Although these six bits are ‘don’t care’, Infineon recommends that these bits be set to 0s to enable seamless transition to higher memory densities.

3.3.7 Serial Opcode

After the slave device is selected with \overline{CS} going LOW, the first byte received is treated as the opcode for the intended operation. CY15B102QM uses the standard opcodes for memory accesses.

3.3.8 Invalid Opcode

If an invalid opcode is received, the opcode is ignored and the device ignores any additional serial data on the SI pin until the next falling edge of CS, and the SO pin remains tristated.

3.3.9 Status Register

CY15B102QM has an 8-bit Status Register. The bits in the Status Register are used to configure the device. These bits are described in [Table 4](#).

3.4 SPI modes

CY15B102QM may be driven by a microcontroller with its SPI peripheral running in either of the following two modes:

- SPI Mode 0 (CPOL = 0, CPHA = 0)
- SPI Mode 3 (CPOL = 1, CPHA = 1)

For both these modes, the input data is latched in on the rising edge of SCK starting from the first rising edge after $\overline{\text{CS}}$ goes active. If the clock starts from a HIGH state (in mode 3), the first rising edge after the clock toggles is considered. The output data is available on the falling edge of SCK. The two SPI modes are shown in **Figure 4** and **Figure 5**. The status of the clock when the bus master is not transferring data is:

- SCK remains at 0 for Mode 0
- SCK remains at 1 for Mode 3

The device detects the SPI mode from the status of the SCK pin when the device is selected by bringing the $\overline{\text{CS}}$ pin LOW. If the SCK pin is LOW when the device is selected, SPI Mode 0 is assumed and if the SCK pin is HIGH, it works in SPI Mode 3.

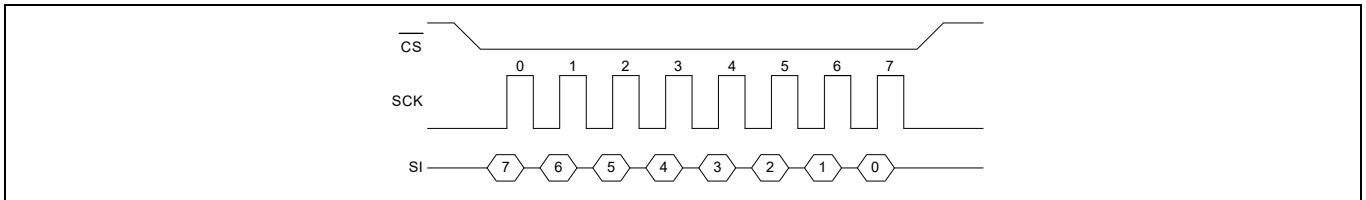

Figure 4 SPI mode 0

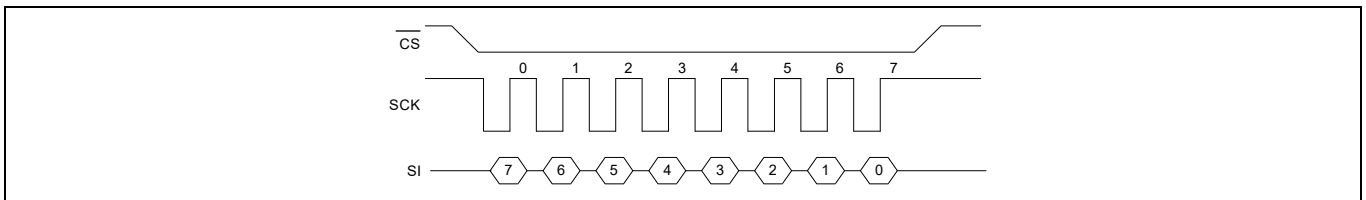

Figure 5 SPI mode 3

3.5 Power-up to first access

The CY15B102QM is not accessible for a t_{PU} time after power-up. Users must comply with the timing parameter, t_{PU} , which is the minimum time from V_{DD} (min) to the first $\overline{\text{CS}}$ LOW. Refer to **“Power cycle timing”** on page 29 for details.

4 Functional description

4.1 Command structure

There are 13 commands, called opcodes, that can be issued by the bus master to the CY15B102QM (see [Table 2](#)). These opcodes control the functions performed by the memory.

Table 2 Opcode commands

Name	Description	Opcode		Max. Frequency (MHz)
		Hex	Binary	
Register Access				
RDSR	Read Status Register	05h	0000 0101b	50
WRSR	Write Status Register	01h	0000 0001b	50
Memory Write				
WRITE	Write memory data	02h	0000 0010b	50
Memory Read				
READ	Read memory data	03h	0000 0011b	40
FSTRD	Fast read memory data	0Bh	0000 1011b	50
Special Sector Memory Access				
SSWR	Special Sector Write	42h	0100 0010b	50
SSRD	Special Sector Read	4Bh	0100 1011b	40
Identification and Serial Number				
RDID	Read device ID	9Fh	1001 1111b	50
RUID	Read Unique ID	4Ch	0100 1100b	50
WRSN	Write Serial Number	C2h	1100 0010b	50
RDSN	Read Serial Number	C3h	11000 011b	50
Low Power Mode Commands				
DPD	Enter Deep Power-Down	BAh	1011 1010b	50
HBN	Enter Hibernate Mode	B9h	1011 1001b	50
Reserved				
Reserved	Reserved	Unused opcodes are reserved for future use.		–

Functional description

Status register and write protection

The write protection features of the CY15B102QM are multi-tiered and are enabled through the status register. The Status Register is organized as follows. (The default value shipped from the factory for BP0, BP1, bits 4–5, and WPEN is ‘0’ and WEL, bit 6 is ‘1’).

Table 3 Status register

Bit 7	Bit 6	Bit 5	Bit 4	Bit 3	Bit 2	Bit 1	Bit 0
WPEN (0)	X (1)	X (0)	X (0)	BP1 (0)	BP0 (0)	WEL (1)	X (0)

Table 4 Status register bit definition

Bit	Definition	Description
Bit 0	Don't care	This bit is non-writable and always returns ‘0’ upon read.
Bit 1 (WEL)	Write Enable (Don't Care)	WEL indicates if the device is write enabled. This bit defaults to ‘1’ (enabled) on power-up. WEL = 1 = Write enabled This bit is non-writable and always returns ‘1’ upon read. WEL is not reset after executing write (WRSR, WRITE, WRSN, SSWR) commands.
Bit 2 (BP0)	Block Protect bit ‘0’	Used for block protection. For details, see Table 5 .
Bit 3 (BP1)	Block Protect bit ‘1’	Used for block protection. For details, see Table 5 .
Bit 4–5	Don't care	These bits are non-writable and always return ‘0’ upon read.
Bit 6	Don't care	This bit is non-writable and always returns ‘1’ upon read.
Bit 7 (WPEN)	WriteProtect Enablebit	Used to enable the function of Write Protect Pin (\overline{WP}). For details, see Table 6 .

Bits 0 and 4–5 are fixed at ‘0’ and WEL, bit 6 is fixed at ‘1’; none of these bits can be modified. Note that bit 0 (“Ready or Write in progress” bit in serial flash and EEPROM) is unnecessary, as the F-RAM writes in real-time and is never busy, so it reads out as a ‘0’. An exception to this is when the device is waking up either from “**Deep power-down mode (DPD, BAh)**” on page 18 or “**Hibernate mode (HBN, B9h)**” on page 19. The BP1 and BP0 control the software write-protection features and are nonvolatile bits. The WEL flag indicates the state of the Write Enable Latch. Attempting to directly write the WEL bit in the Status Register has no effect on its state. This bit is internally set permanently on power-up and does not clear to ‘0’ on the rising edge of CS following any write (WRSR, WRITE, WRSN, SSWR) commands.

BP1 and BP0 are memory block write protection bits. They specify portions of memory that are write-protected as shown in [Table 5](#).

Table 5 Block memory write protection

BP1	BP0	Protected address range
0	0	None
0	1	30000h to 3FFFFh (upper 1/4)
1	0	20000h to 3FFFFh (upper 1/2)
1	1	00000h to 3FFFFh (all)

The BP1 and BP0 bits are the only mechanisms that protect the memory from writes. The remaining write protection features protect inadvertent changes to the block protect bits.

The write protect enable bit (WPEN) in the Status Register controls the effect of the hardware write protect (\overline{WP}) pin. Refer to [Figure 21](#) for the \overline{WP} pin timing diagram. When the WPEN bit is set to ‘0’, the status of the \overline{WP} pin is ignored. When the WPEN bit is set to ‘1’, a LOW on the \overline{WP} pin inhibits a write to the Status Register. Thus the Status Register is write-protected only when WPEN = ‘1’ and \overline{WP} = ‘0’. [Table 6](#) summarizes the write protection conditions.

Table 6 Write protection

WEL	WPEN	WP	Protected blocks	Unprotected blocks	Status register
1	0	X	Protected	Unprotected	Unprotected
1	1	0	Protected	Unprotected	Protected
1	1	1	Protected	Unprotected	Unprotected

4.1.1 Register access commands

Read Status Register (RDSR, 05h)

The RDSR command allows the bus master to verify the contents of the Status Register. Reading the Status Register provides information about the current state of the write-protection features. Following the RDSR opcode, the CY15B102QM will return one byte with the contents of the Status Register.

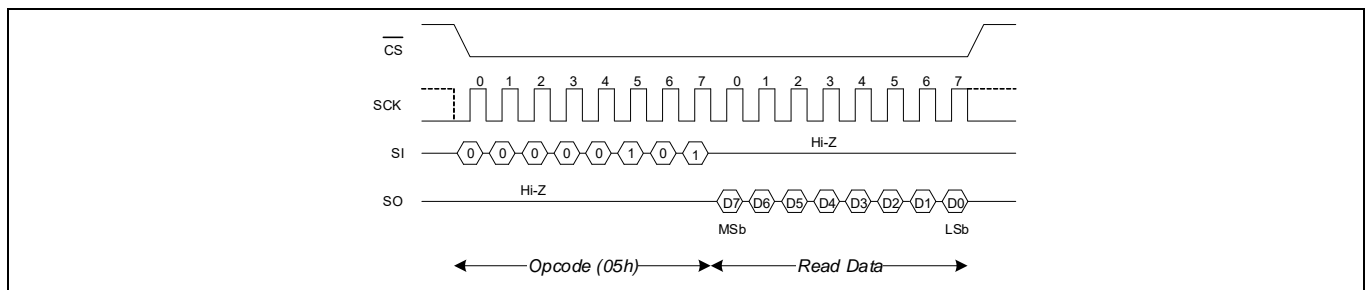

Figure 6 RDSR bus configuration

Write Status Register (WRSR, 01h)

The WRSR command allows the SPI bus master to write into the Status Register and change the write protect configuration by setting the WPEN, BP0, and BP1 bits as required. Before issuing a WRSR command, the WP pin must be HIGH or inactive. Note that on the CY15B102QM, WP only prevents writing to the Status Register, not the memory array.

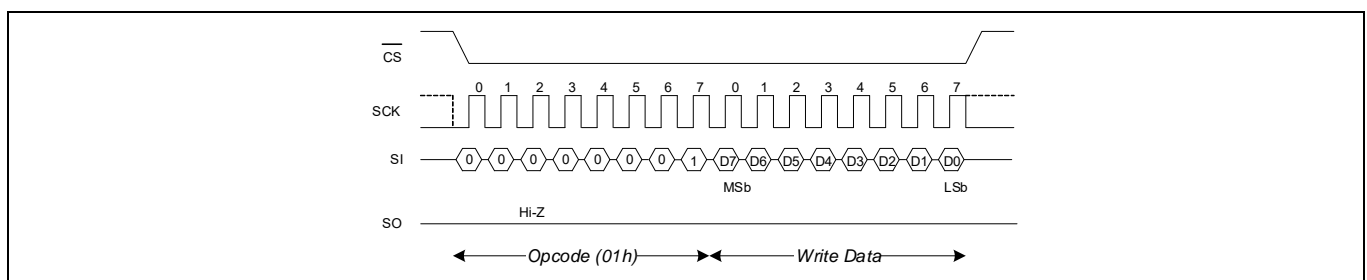

Figure 7 WRSR bus configuration

4.1.2 Memory operation

The SPI interface, which is capable of a high clock frequency, highlights the fast write capability of the F-RAM technology. Unlike serial flash and EEPROMs, the CY15B102QM can perform sequential writes at bus speed. No page register is needed and any number of sequential writes may be performed.

4.1.3 Memory write operation commands

Write operation (WRITE, 02h)

All writes to the memory begin with a WRITE opcode with \overline{CS} being asserted. The WRITE opcode is followed by a three-byte address containing the 18-bit address (A17–A0) of the first data byte to be written into the memory. The upper six bits of the three-byte address are ignored. Subsequent bytes are data bytes, which are written sequentially. Addresses are incremented internally as long as the bus master continues to issue clocks and keeps \overline{CS} LOW. If the last address of 3FFFFh is reached, the internal address counter will roll over to 00000h. Every data byte to be written is transmitted on SI in 8-clock cycles with MSb first and the LSb last. The rising edge of \overline{CS} terminates a write operation. The CY15B102QM write operation is shown in **Figure 8**.

Notes

- When a burst write reaches a protected block address, the automatic address increment stops and all the subsequent data bytes received for write will be ignored by the device. EEPROMs use page buffers to increase their write throughput. This compensates for the technology's inherently slow write operations. F-RAM memories do not have page buffers because each byte is written to the F-RAM array immediately after it is clocked in (after the eighth clock). This allows any number of bytes to be written without page buffer delays.
- If power is lost in the middle of the write operation, only the last completed byte will be written.

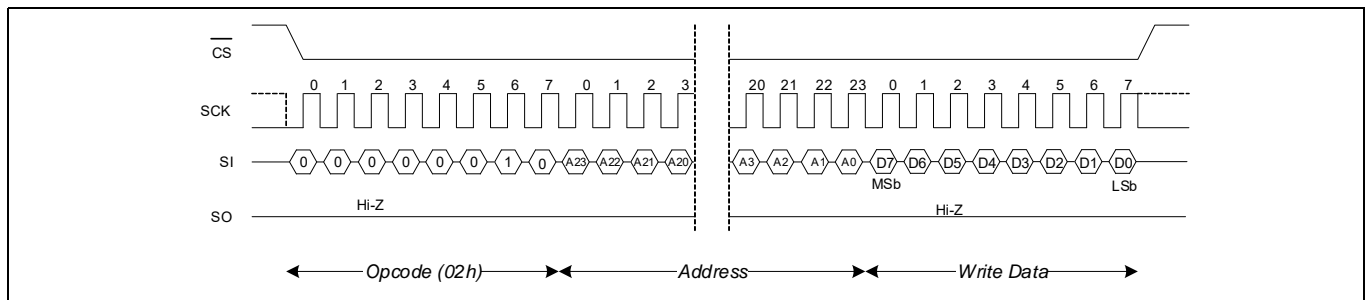

Figure 8 Memory write operation

4.1.4 Memory read operation commands

Read operation (READ, 03h)

After the falling edge of \overline{CS} , the bus master can issue a READ opcode. Following the READ command is a three-byte address containing the 18-bit address (A17–A0) of the first byte of the read operation. The upper six bits of the address are ignored. After the opcode and address are issued, the device drives out the read data on the next eight clocks. The SI input is ignored during read data bytes. Subsequent bytes are data bytes, which are read out sequentially. Addresses are incremented internally as long as the bus master continues to issue clocks and \overline{CS} is LOW. If the last address of 3FFFFh is reached, the internal address counter will roll over to 00000h. The device also provides a writable, 8-byte serial number registers, which can be used to identify a specific board or a system. The rising edge of \overline{CS} terminates a read operation and tristates the SO pin. The CY15B102QM read operation is shown in **Figure 9**.

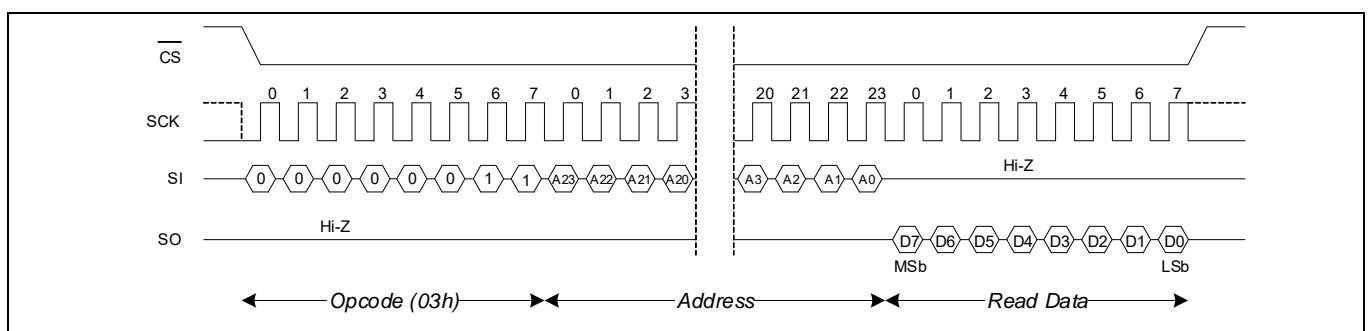

Figure 9 Memory read operation

Fast read operation (FAST_READ, 0Bh)

The CY15B102QM supports a FAST READ opcode (0Bh) that is provided for opcode compatibility with serial flash devices. The FAST READ opcode is followed by a three-byte address containing the 18-bit address (A17–A0) of the first byte of the read operation and then a dummy byte. The dummy byte inserts a read latency of 8-clock cycle. The fast read operation is otherwise the same as an ordinary read operation except that it requires an additional dummy byte. After receiving the opcode, address, and a dummy byte, the CY15B102QM starts driving its SO line with data bytes, with MSb first, and continues transmitting as long as the device is selected and the clock is available. In case of bulk read, the internal address counter is incremented automatically, and after the last address 3FFFFh is reached, the internal address counter rolls over to 00000h. When the device is driving data on its SO line, any transition on its SI line is ignored. The rising edge of \overline{CS} terminates a fast read operation and tristates the SO pin. The CY15B102QM Fast Read operation is shown in **Figure 10**.

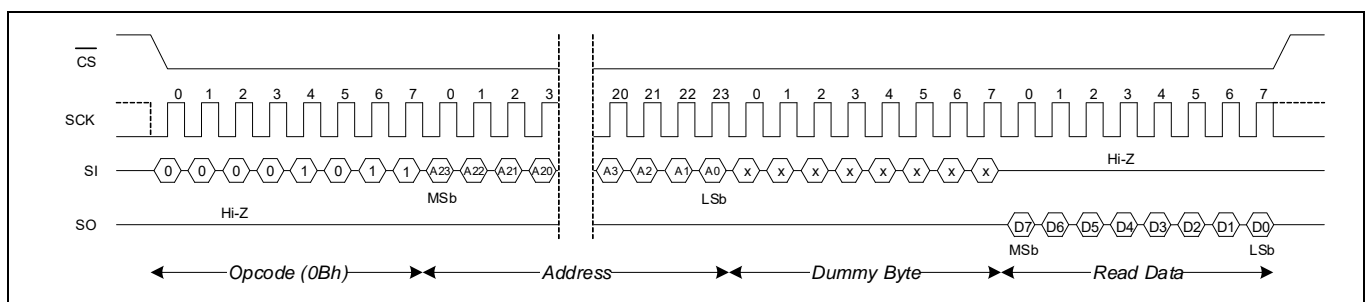

Figure 10 Fast read operation

4.1.5 Special sector memory access commands

Special sector write (SSWR, 42h)

All writes to the 256-byte special begin with a SSWR opcode with \overline{CS} being asserted. The SSWR opcode is followed by a three-byte address containing the 8-bit sector address (A7–A0) of the first data byte to be written into the special sector memory. The upper 16 bits of the three-byte address are ignored. Subsequent bytes are data bytes, which are written sequentially. Addresses are incremented internally as long as the bus master continues to issue clocks and keeps \overline{CS} LOW. Once the internal address counter auto increments to XXX7Fh, \overline{CS} should toggle HIGH to terminate the ongoing SSWR operation. Every data byte to be written is transmitted on SI in 8-clock cycles with MSb first and the LSb last. The rising edge of \overline{CS} terminates a write operation. The CY15B102QM special sector write operation is shown in **Figure 11**.

Notes

- If power is lost in the middle of the write operation, only the last completed byte will be written.
- The special sector F-RAM memory guarantees to retain data integrity up to three cycles of standard reflow soldering.

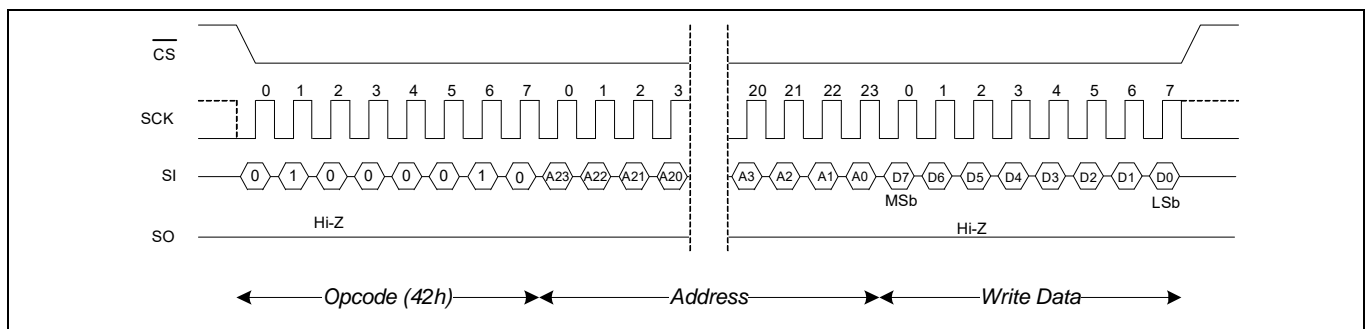

Figure 11 Special sector write operation

Special sector read (SSRD, 4Bh)

After the falling edge of \overline{CS} , the bus master can issue an SSRD opcode. Following the SSRD command is a three-byte address containing the 8-bit address (A7–A0) of the first byte of the special sector read operation. The upper 16 bits of the address are ignored. After the opcode and address are issued, the device drives out the read data on the next eight clocks. The SI input is ignored during read data bytes. Subsequent bytes are data bytes, which are read out sequentially. Addresses are incremented internally as long as the bus master continues to issue clocks and \overline{CS} is LOW. Once the internal address counter auto increments to XXX7Fh, \overline{CS} should toggle HIGH to terminate the ongoing SSRD operation. Every read data byte on SO is driven in 8-clock cycles with MSb first and the LSb last. The rising edge of \overline{CS} terminates a special sector read operation and tristates the SO pin. The CY15B102QM special sector read operation is shown in **Figure 12**.

Note The special sector F-RAM memory guarantees to retain data integrity up to three cycles of standard reflow soldering.

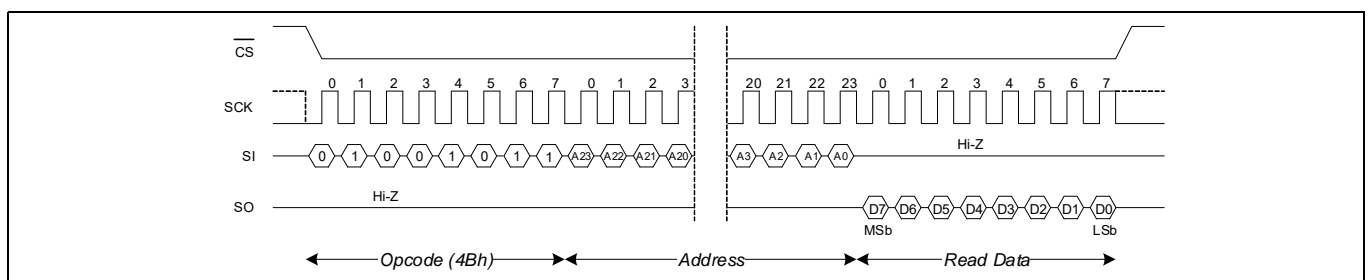

Figure 12 Special sector write read operation

4.1.6 Identification and serial number commands

Read device ID (RDID, 9Fh)

The CY15B102QM device can be interrogated for its manufacturer, product identification, and die revision. The RDID opcode 9Fh allows the user to read the 9-byte manufacturer ID and product ID, both of which are read-only bytes. The JEDEC-assigned manufacturer ID places the Cypress (Ramtron) identifier in bank 7; therefore, there are six bytes of the continuation code 7Fh followed by the single byte C2h. There are two bytes of product ID, which includes a family code, a density code, a sub code, and the product revision code. Table 6 shows 9-Byte Device ID field description. Refer to **“Ordering information”** on page 30 for 9-Byte device ID of an individual part. The CY15B102QM read device ID operation is shown in **Figure 13**.

Note The least significant data byte (Byte 0) shifts out first and the most significant data byte (Byte 8) shifts out last.

Table 7 9-byte device ID

Device ID field description							
Manufacturer ID [71:16]	Family [15:13]	Density [12:9]	Inrush [8]	Sub type [7:5]	Revision [4:3]	Voltage [2]	Frequency [1:0]
56-bit	3-bit	4-bit	1-bit	3-bit	2-bit	1-bit	2-bit

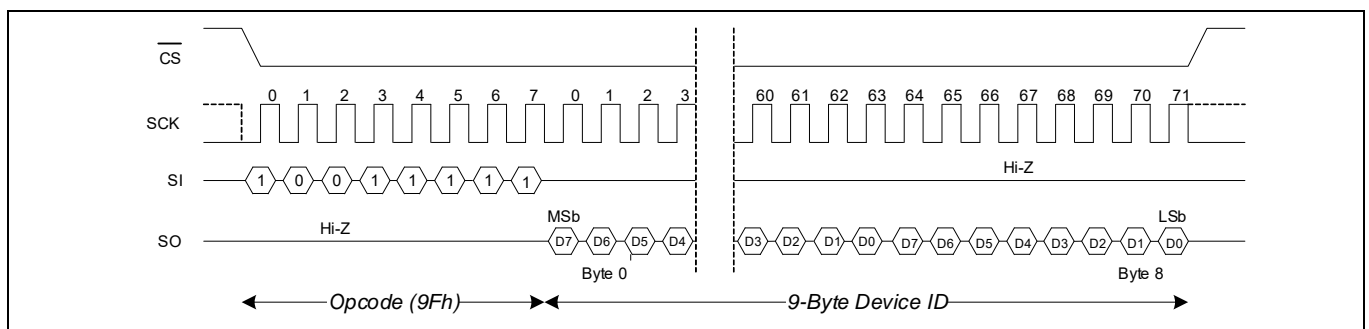

Figure 13 Read device ID

Read unique ID (RUID, 4Ch)

The CY15B102QM device can be interrogated for unique ID which is a factory programmed, 64-bit number unique to each device. The RUID opcode, 4Ch allows to read the 8-byte, read only unique ID. The CY15B102QM read unique ID operation is shown in **Figure 14**.

Notes

- The least significant data byte (Byte 0) shifts out first and the most significant data byte (Byte 7) shifts out last.
- The unique ID registers are guaranteed to retain data integrity of up to three cycles of the standard reflow soldering.

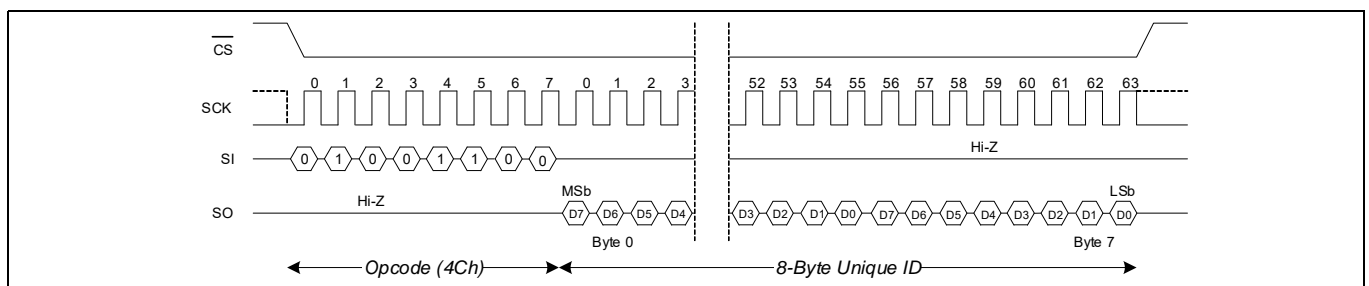

Figure 14 Read unique ID

Functional description

Write serial number (WRSN, C2h)

The serial number is an 8-byte one-time programmable memory space provided to the user to uniquely identify a PC board or a system. A serial number typically consists of a two-byte Customer ID, followed by five bytes of a unique serial number and one byte of CRC check. However, the end application can define its own format for the 8-byte serial number. All writes to the Serial Number Register begin with a WRSN opcode with \overline{CS} being asserted. The WRSN instruction can be used in burst mode to write all the 8 bytes of serial number. After the last byte of the serial number is shifted in, \overline{CS} must be driven high to complete the WRSN operation. The CY15B102QM write serial number operation is shown in [Figure 15](#).

Note The CRC checksum is not calculated by the device. The system firmware must calculate the CRC checksum on the 7-byte content and append the checksum to the 7-byte user-defined serial number before programming the 8-byte serial number into the serial number register. The factory default value for the 8-byte Serial Number is '0000000000000000h'.

Table 8 8-byte serial number

16-bit customer identifier		40-bit unique number					8-bit CRC
SN[63:56]	SN[55:48]	SN[47:40]	SN[39:32]	SN[31:24]	SN[23:16]	SN[15:8]	SN[7:0]

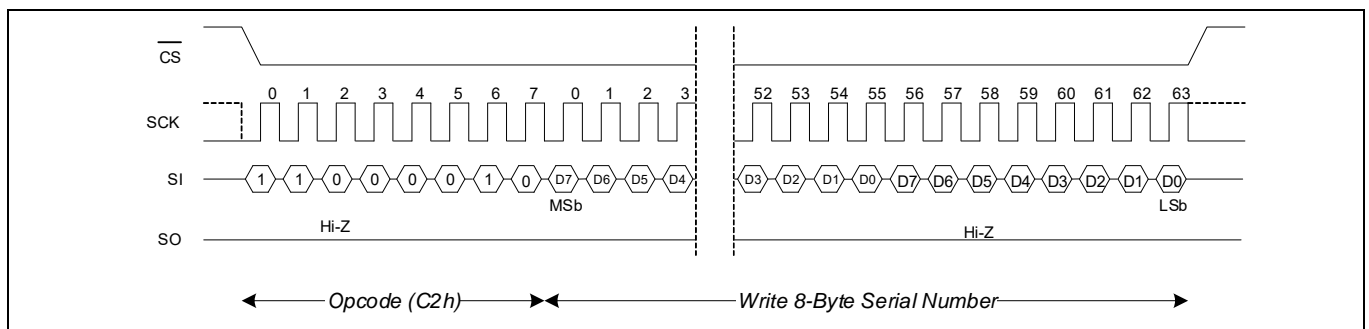

Figure 15 Write serial number operation

Read serial number (RDSN, C3h)

The CY15B102QM device incorporates an 8-byte serial space provided to the user to uniquely identify the device. The serial number is read using the RDSN instruction. A serial number read may be performed in burst mode to read all the eight bytes at once. After the last byte of the serial number is read, the device loops back to the first byte of the serial number. An RDSN instruction can be issued by shifting the opcode for RDSN after \overline{CS} goes LOW. The CY15B102QM read serial number operation is shown in [Figure 16](#).

Note The least significant data byte (Byte 0) shifts out first and the most significant data byte (Byte 7) shifts out last.

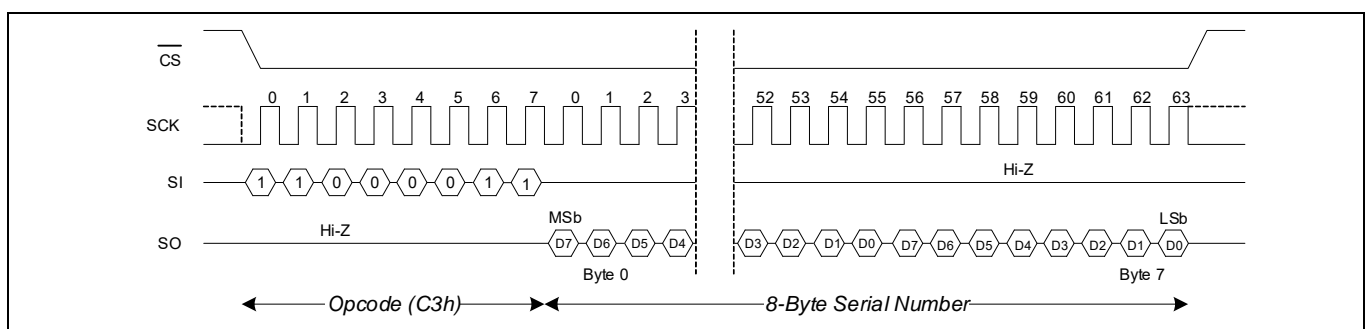

Figure 16 Read serial number operation

4.1.7 Low power mode commands

Deep power-down mode (DPD, BAh)

A power-saving Deep Power-Down mode is implemented on the CY15B102QM device. The device enters the Deep Power-Down mode after t_{ENTDPD} time after the DPD opcode BAh is clocked in and a rising edge of \overline{CS} is applied. When in Deep Power-Down mode, the SCK and SI pins are ignored and SO will be Hi-Z, but the device continues to monitor the \overline{CS} pin.

A \overline{CS} pulse-width of t_{CSDPD} exits the DPD mode after t_{EXTDPD} time. The \overline{CS} pulse-width can be generated either by sending a dummy command cycle or toggling \overline{CS} alone while SCK and I/Os don't care. The I/Os remain in hi-Z state during the wakeup from deep power-down. Refer to [Figure 17](#) for DPD entry and [Figure 18](#) for DPD exit timing.

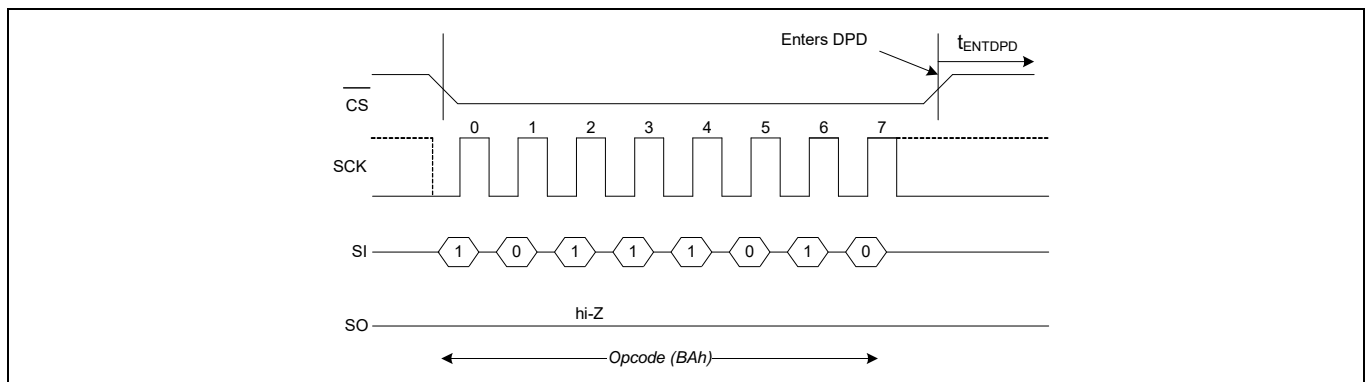

Figure 17 DPD entry timing

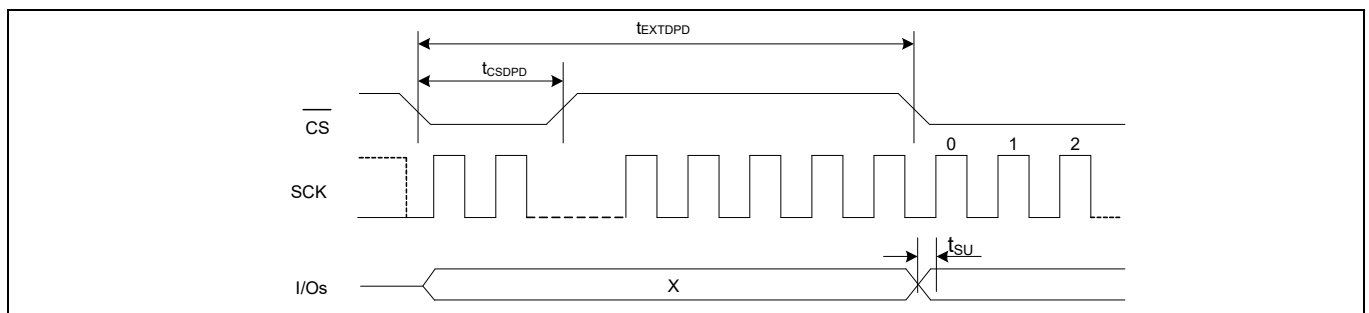

Figure 18 DPD exit timing

Functional description

Hibernate mode (HBN, B9h)

A lowest power Hibernate mode is implemented on the CY15B102QM device. The device enters Hibernate mode after t_{ENTHIB} time after the HBN opcode B9h is clocked in and a rising edge of \overline{CS} is applied. When in Hibernate mode, the SCK and \overline{SI} pins are ignored and SO will be Hi-Z, but the device continues to monitor the \overline{CS} pin. On the next falling edge of \overline{CS} , the device will return to normal operation within t_{EXTHIB} time. The SO pin remains in a Hi-Z state during the wakeup from hibernate period. The device does not necessarily respond to an opcode within the wakeup period. To exit the Hibernate mode, the controller may send a “dummy” read, for example, and wait for the remaining t_{EXTHIB} time.

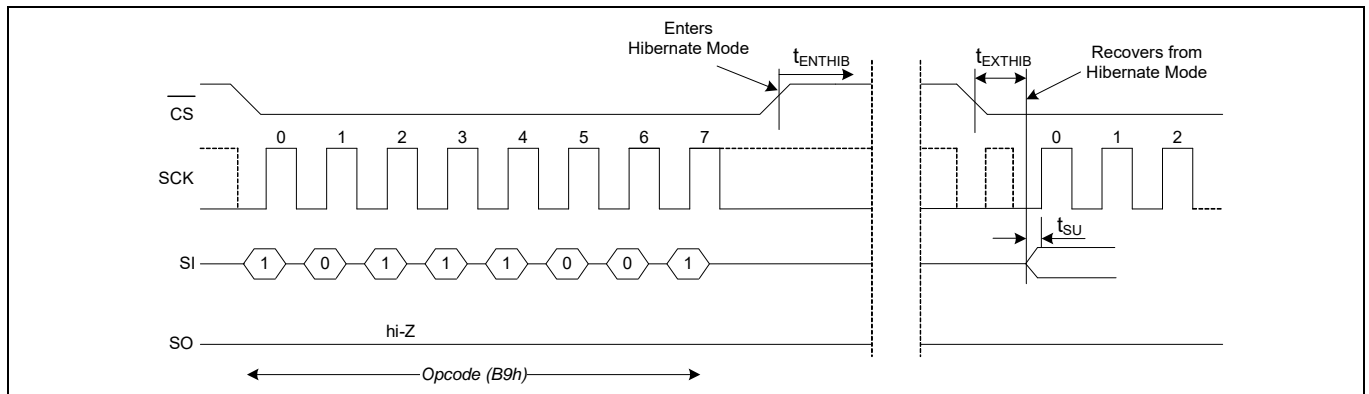

Figure 19 Hibernate mode operation

Endurance

The CY15B102QM devices are capable of being accessed at least 10^{15} times, reads or writes. An F-RAM memory operates with a read and restore mechanism. Therefore, an endurance cycle is applied on a row basis for each access (read or write) to the memory array. The F-RAM architecture is based on an array of rows and columns of 32K rows of 64-bit each. The entire row is internally accessed once, whether a single byte or all eight bytes are read or written. Each byte in the row is counted only once in an endurance calculation. **Table 9** shows endurance calculations for a 64-byte repeating loop, which includes an opcode, a starting address, and a sequential 64-byte data stream. This causes each byte to experience one endurance cycle through the loop. F-RAM read and write endurance is virtually unlimited at a 50-MHz clock rate.

Table 9 Time to reach endurance limit for repeating 64-byte loop

SCK freq (MHz)	Endurance cycles/sec	Endurance cycles/year	Years to reach 10^{15} limit
50	91,900	2.90×10^{12}	345
40	73,040	2.30×10^{12}	43.
20	36,520	1.16×10^{12}	864
10	18,380	5.79×10^{11}	1727
5	9,190	2.90×10^{11}	3454

Maximum ratings

5 Maximum ratings

Exceeding the maximum ratings may impair the useful life of the device. User guidelines are not tested.

Storage temperature	-65°C to +125°C
Maximum accumulated storage time	
At 125°C ambient temperature	1000 h
At 85°C ambient temperature	10 Years
Maximum junction temperature	125°C
Supply voltage on V_{DD} relative to V_{SS} :	
CY15B102QM:	-0.5 V to +4.1 V
Input voltage	$V_{IN} \leq V_{DD} + 0.5 V$
DC voltage applied to outputs in High-Z state	-0.5 V to $V_{DD} + 0.5 V$
Transient voltage (< 20 ns) on any pin to ground potential	-2.0 V to $V_{DD} + 2.0 V$
Package power dissipation capability ($T_A = 25^\circ C$)	1.0 W
Surface mount lead soldering temperature (3 seconds)	+260°C
DC output current (1 output at a time, 1s duration)	15 mA
Electrostatic discharge voltage	
Human Body Model (JEDEC Std JESD22-A114-B)	2 kV
Charged Device Model (JEDEC Std JESD22-C101-A)	500 V
Latch-up current	>140 mA

Operating range

6 Operating range

Table 10 Operating range

Device	Range	Ambient temperature	V _{DD}
CY15B102QM	Industrial	-40°C to +85°C	1.8 V to 3.6 V

7 DC electrical characteristics

Table 11 DC electrical characteristics

Over the **Operating range**

Parameter	Description	Test conditions	Min	Typ ^[2,3]	Max	Unit	
V _{DD}	Power supply	–	1.80	3.30	3.60	V	
I _{DD}	V _{DD} supply current	V _{DD} = 1.8 V to 3.6 V; SCK toggling between V _{DD} – 0.2 V and V _{SS} , other inputs V _{SS} or V _{DD} – 0.2 V. SO = Open	f _{SCK} = 40 MHz	–	2.4	3	mA
			f _{SCK} = 50 MHz	–	3	3.7	mA
I _{SB}	V _{DD} standby current	V _{DD} = 1.8 V to 3.6 V; CS = V _{DD} . All other inputs V _{SS} or V _{DD}	T _A = 25°C	–	2.6	–	μA
			T _A = 85°C	–		70	μA
I _{DPD}	Deep power down current	V _{DD} = 1.8 V to 3.6 V; CS = V _{DD} . All other inputs V _{SS} or V _{DD}	T _A = 25°C	–	0.8	–	μA
			T _A = 85°C	–		16	μA
I _{HBN}	Hibernate mode current	V _{DD} = 1.8 V to 3.6 V; CS = V _{DD} . All other inputs V _{SS} or V _{DD} .	T _A = 25°C	–	0.1	–	μA
			T _A = 85°C	–		1.6	μA
I _{LI}	Input leakage current on I/O pins except WP pin	V _{SS} < V _{IN} < V _{DD}		–1	–	1	μA
	Input leakage current on WP pin			–100	–	1	μA
I _{LO}	Output leakage current	V _{SS} < V _{OUT} < V _{DD}	–1	–	1	μA	
V _{IH}	Input HIGH voltage	–	0.7 × V _{DD}	–	V _{DD} + 0.3	V	
V _{IL}	Input LOW voltage	–	–0.3	–	0.3 × V _{DD}	V	
V _{OH1}	Output HIGH voltage	I _{OH} = –1 mA, V _{DD} = 2.7 V	2.40	–	–	V	
V _{OH2}	Output HIGH voltage	I _{OH} = –100 μA	V _{DD} – 0.2	–	–	V	
V _{OL1}	Output LOW voltage	I _{OL} = 2 mA, V _{DD} = 2.7 V	–	–	0.40	V	
V _{OL2}	Output LOW voltage	I _{OL} = 150 μA	–	–	0.20	V	

Notes

2. Typical values are at 25°C, V_{DD} = V_{DD (typ)}.
3. This parameter is guaranteed by characterization; not tested in production.

8 Data retention and endurance

Table 12 Data retention and endurance

Parameter	Description	Test conditions	Min	Max	Unit
T _{DR}	Data retention	T _A = 85°C	10	–	Years
		T _A = 70°C	141	–	Years
		T _A = 60°C	151	–	Years
		T _A = 50°C	160	–	Years
NV _C	Endurance	Over operating temperature	10 ¹⁵	–	Cycles

Capacitance

9 Capacitance

Table 13 Capacitance

For all packages.

Parameter ^[4]	Description	Test conditions	Max	Unit
C _O	Output pin capacitance (SO)	T _A = 25°C, f = 1 MHz, V _{DD} = V _{DD(typ)}	8	pF
C _I	Input pin capacitance		6	pF

Note

4. This parameter is guaranteed by characterization; not tested in production.

Thermal resistance

10 Thermal resistance

Table 14 Thermal resistance

Parameter ^[5]	Description	Test conditions	8-pin SOIC package	Unit
Θ_{JA}	Thermal resistance (junction to ambient)	Test conditions follow standard test methods and procedures for measuring thermal impedance, per EIA/JESD51.	96.0	°C/W
Θ_{JC}	Thermal resistance (junction to case)		86.8	°C/W

Note

5. This parameter is guaranteed by characterization; not tested in production.

11 AC test conditions

Input pulse levels	10% and 90% of V_{DD}
Input rise and fall times	3 ns
Input and output timing reference levels	$0.5 \times V_{DD}$
Output load capacitance	30 pF

12 AC switching characteristics

Table 15 AC switching characteristics

Over the **Operating range**

Parameters ^[6]		Description	40 MHz		50 MHz		Unit
Parameter	Alt. Parameter		Min	Max	Min	Max	
f _{SCK}	–	SCK clock frequency	0	40	0	50	MHz
t _{CH}	–	Clock HIGH time	11	–	9	–	ns
t _{CL}	–	Clock LOW time	11	–	9	–	ns
t _{CLZ} ^[7]	–	Clock LOW to Output low-Z	0	–	0	–	ns
t _{CSS}	t _{CSU}	Chip select setup	5	–	5	–	ns
t _{CSH}	t _{CSH}	Chip select hold - mode 0	5	–	5	–	ns
t _{CSH1}	t _{CSH1}	Chip select hold - mode 3	10	–	10	–	ns
t _{HZCS}	t _{OD} ^[8,9]	Output disable time	–	12	–	10	ns
t _{CO}	t _{ODV}	Output data valid time	–	9	–	8	ns
t _{OH}	–	Output hold time	1	–	1	–	ns
t _{CS}	t _D	Deselect time	40	–	40	–	ns
t _{SD}	t _{SU}	Data setup time	5	–	5	–	ns
t _{HD}	t _H	Data hold time	5	–	5	–	ns
t _{WPS}	t _{WHSL}	\overline{WP} setup time (w.r.t \overline{CS})	20	–	20	–	ns
t _{WPH}	t _{SHWL}	\overline{WP} hold time (w.r.t \overline{CS})	20	–	20	–	ns

Notes

- Test conditions assume a signal transition time of 3 ns or less, timing reference levels of $0.5 \times V_{DD}$, input pulse levels of 10% to 90% of V_{DD} , and output loading of the specified I_{OL}/I_{OH} and 30-pF load capacitance shown in **“AC test conditions”** on page 26.
- Guaranteed by design.
- t_{HZCS} is specified with a load capacitance of 5 pF. Transition is measured when the output enters a high-impedance state.
- This parameter is guaranteed by characterization; not tested in production.

AC switching characteristics

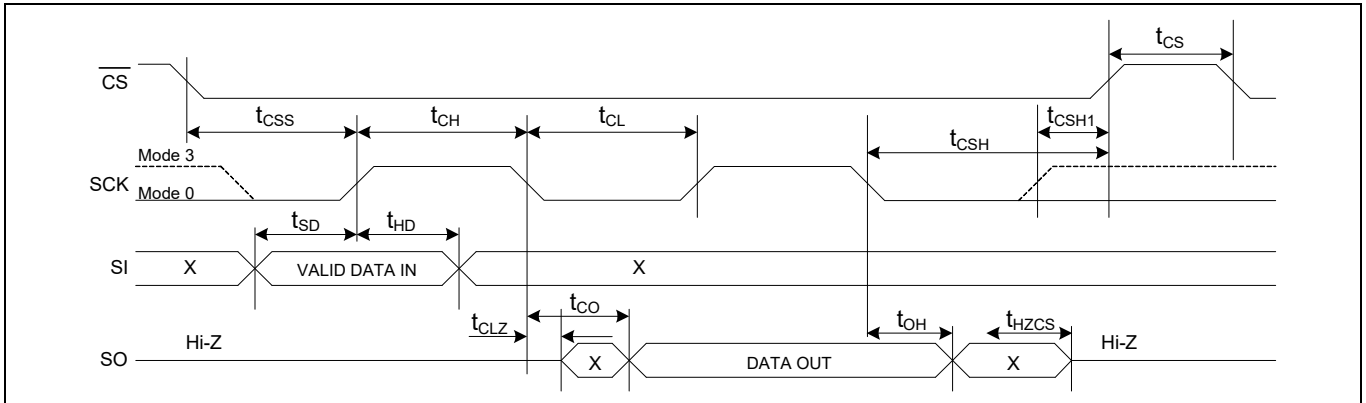

Figure 20 Synchronous data timing (Mode 0 and Mode 3)

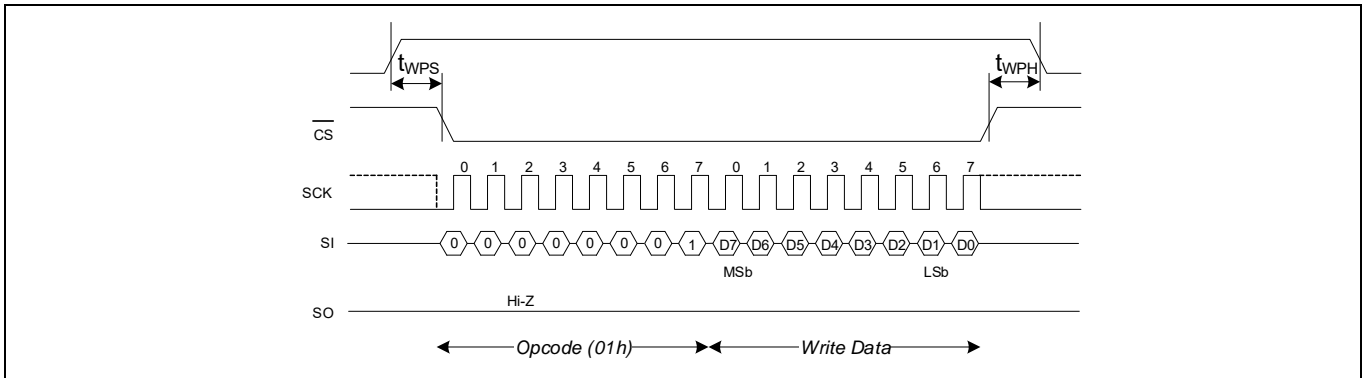

Figure 21 Write protect timing during write status register (WRSR) operation

13 Power cycle timing

Table 16 Power cycle timing

Over the **Operating range**

Parameters ^[10]		Description	Min	Max	Unit
Parameter	Alt. Parameter				
t_{PU}	–	Power-up $V_{DD(min)}$ to first access (\overline{CS} LOW)	450	–	μs
t_{VR} ^[11]	–	V_{DD} power-up ramp rate	50	–	$\mu s/V$
t_{VF} ^[11, 12]	–	V_{DD} power-down ramp rate	100	–	$\mu s/V$
t_{ENTDPD} ^[13]	t_{PD}	\overline{CS} HIGH to enter deep power-down (\overline{CS} HIGH to deep power-down mode current)	–	3	μs
t_{CSDPD}	–	\overline{CS} pulse width to wake up from deep power-down mode	0.015	$4 \times 1/f_{SCK}$	μs
t_{EXTDPD}	t_{RPD}	\overline{CS} LOW to exit deep-power-down (\overline{CS} LOW to ready for access)	–	10	μs
t_{ENTHIB} ^[14]	–	\overline{CS} HIGH to enter hibernate (\overline{CS} HIGH to enter hibernate mode current)	–	3	μs
t_{EXTHIB}	t_{REC}	\overline{CS} LOW to exit hibernate (\overline{CS} LOW to ready for access)	–	450	μs

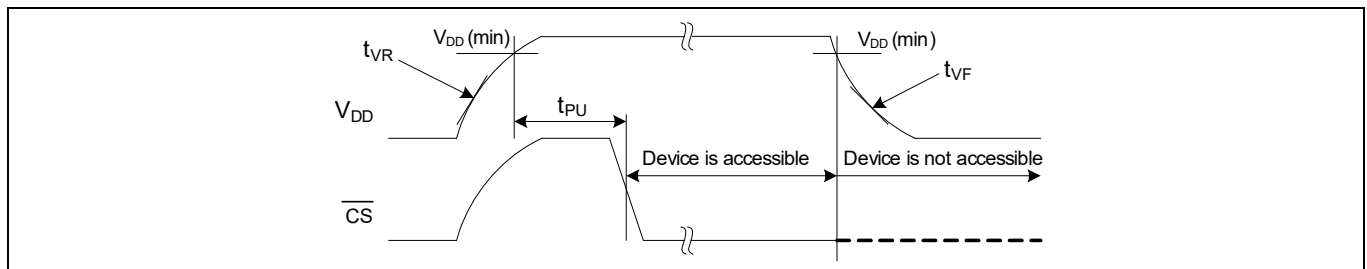

Figure 22 Power cycle timing

Notes

10. Test conditions assume a signal transition time of 3 ns or less, timing reference levels of $0.5 \times V_{DD}$, input pulse levels of 10% to 90% of V_{DD} , and output loading of the specified I_{OL}/I_{OH} and 30-pF load capacitance shown in “AC test conditions” on page 26.
11. Slope measured at any point on the V_{DD} waveform.
12. This parameter is guaranteed by characterization; not tested in production.
13. Guaranteed by design. Refer to **Figure 17** for Deep Power Down mode timing.
14. Guaranteed by design. Refer to **Figure 19** for Hibernate mode timing.

14 Ordering information

Table 17 Ordering part numbers

Ordering code	Device ID	Package diagram	Package type	Operating range
CY15B102QM-50SWXI	7F7F7F7F7F7FC26A00	51-85066	8-pin SOIC	Industrial
CY15B102QM-50SWXIT				

All these parts are Pb-free. Contact your local sales representative for availability of these parts.

14.1 Ordering code definitions

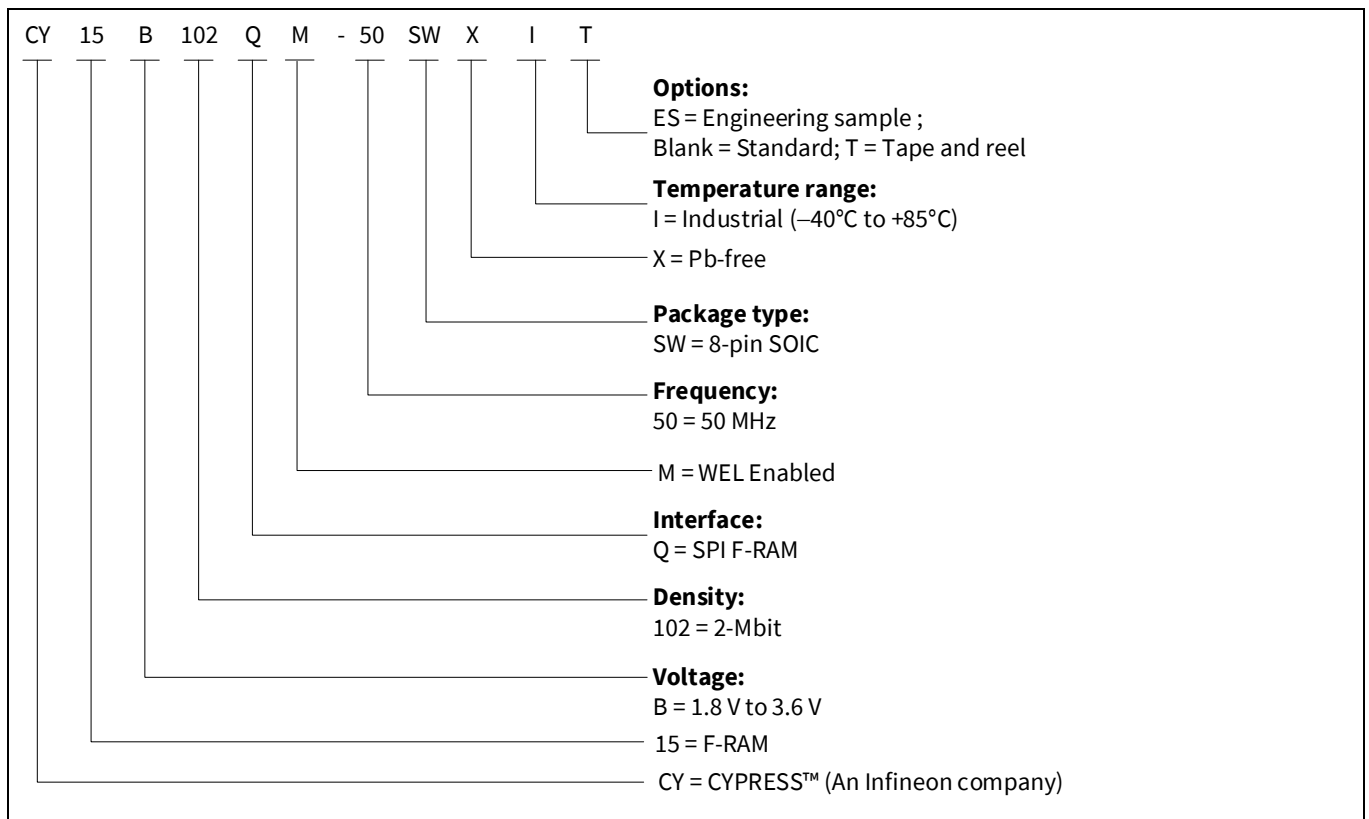

Package diagram

15 Package diagram

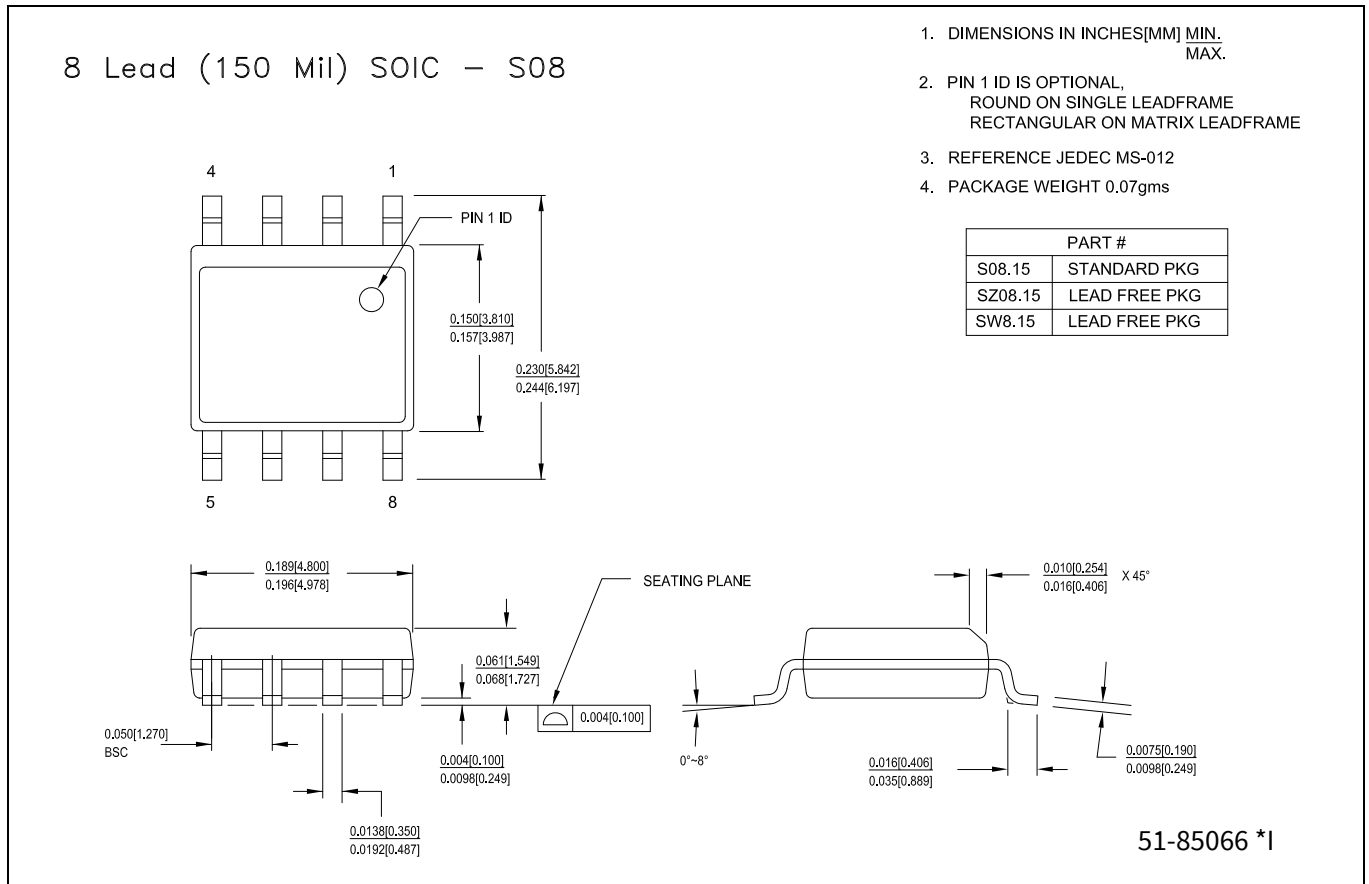

Figure 23 8-pin SOIC (150 Mils) package outline, 51-85066

16 Acronyms

Table 18 Acronyms used in this document

Acronym	Description
CPHA	Clock Phase
CPOL	Clock Polarity
EEPROM	Electrically Erasable Programmable Read-Only Memory
EIA	Electronic Industries Alliance
F-RAM	Ferroelectric Random Access Memory
I/O	Input/Output
JEDEC	Joint Electron Devices Engineering Council
JESD	JEDEC standards
LSb	Least Significant Bit
MSb	Most Significant Bit
RoHS	Restriction of Hazardous Substances
SPI	Serial Peripheral Interface
SOIC	Small Outline Integrated Circuit

17 Document conventions

17.1 Units of measure

Table 19 Units of measure

Symbol	Unit of measure
°C	degree Celsius
Hz	hertz
kHz	kilohertz
kΩ	kilohm
Mbit	megabit
MHz	megahertz
μA	microampere
μF	microfarad
μs	microsecond
mA	milliampere
ms	millisecond
ns	nanosecond
W	ohm
%	percent
pF	picofarad
V	volt
W	watt

Revision history

Revision history

Document revision	Date	Description of changes
*A	2022-01-20	Post to external web.
*B	2022-09-12	Updated Features : Updated description. Updated Pin definitions : Updated Table 1 . Updated to new template.

Trademarks

All referenced product or service names and trademarks are the property of their respective owners.

Edition 2022-09-12
Published by
Infineon Technologies AG
81726 Munich, Germany

© 2022 Infineon Technologies AG.
All Rights Reserved.

Do you have a question about this document?
Go to www.infineon.com/support

Document reference
002-33164 Rev. *B

IMPORTANT NOTICE

The information given in this document shall in no event be regarded as a guarantee of conditions or characteristics ("Beschaffenhheitsgarantie").

With respect to any examples, hints or any typical values stated herein and/or any information regarding the application of the product, Infineon Technologies hereby disclaims any and all warranties and liabilities of any kind, including without limitation warranties of non-infringement of intellectual property rights of any third party.

In addition, any information given in this document is subject to customer's compliance with its obligations stated in this document and any applicable legal requirements, norms and standards concerning customer's products and any use of the product of Infineon Technologies in customer's applications.

The data contained in this document is exclusively intended for technically trained staff. It is the responsibility of customer's technical departments to evaluate the suitability of the product for the intended application and the completeness of the product information given in this document with respect to such application.

For further information on the product, technology, delivery terms and conditions and prices please contact your nearest Infineon Technologies office (www.infineon.com).

WARNINGS

Due to technical requirements products may contain dangerous substances. For information on the types in question please contact your nearest Infineon Technologies office.

Except as otherwise explicitly approved by Infineon Technologies in a written document signed by authorized representatives of Infineon Technologies, Infineon Technologies' products may not be used in any applications where a failure of the product or any consequences of the use thereof can reasonably be expected to result in personal injury.