

USB Billboard controller

Features

- USB 2.0-certified, Full-speed (12 Mbps)
 - Supports native Billboard Device Class Driver
 - Integrated USB termination resistors
- CY7C65210/210A: Single-channel I²C interface
 - Master up to 400 kHz
 - 190 bytes for each transmit and receive buffer
- CY7C65217/217A: Dual-channel UART/I²C interface
 - UART interface
 - Supports 2-pin
 - Data rates up to 115200 bps
 - 190 bytes for each transmit and receive buffer
 - Data format: 7 or 8 data bits, 1 or 2 stop bits
 - No parity, even, odd, mark, or space parity
 - Supports parity, overrun, and framing errors
 - Supports single-channel RS-232 and RS-422 interface
 - I²C interface
 - Master up to 400 kHz
 - 190 bytes for each transmit and receive buffer
- General-purpose input/output (GPIO) pins:
 - CY7C65210: 9
 - CY7C65217: 7
 - CY7C65210A: 11
 - CY7C65217A: 9
- 2560 bytes flash for storing configuration parameters
- Billboard Device Class-specific descriptors
- Driver support for Billboard device
 - Billboard Device Class is natively supported by Windows 10
- Clocking: Integrated 48-MHz clock oscillator
- Supports bus- or self-powered configurations
- USB Suspend mode for low power
- Operating voltage: 1.71 V to 5.5 V
- Operating temperature:
 - Commercial: 0°C to 70°C
 - Industrial: -40°C to 85°C
 - Automotive: -40°C to 105°C
- ESD protection: 2.2 kV HBM
- RoHS-compliant package
 - 24-lead QFN (4.0 mm × 4.0 mm, 0.55 mm, 0.5-mm pitch)

Applications

Applications

Any Type-C Device Container that supports Alternate Mode requires Billboard device support such as:

- Dongles for Type-C
- Docking stations
- Monitors
- Automotive

Block diagram - CY7C65210/CY7C65210A

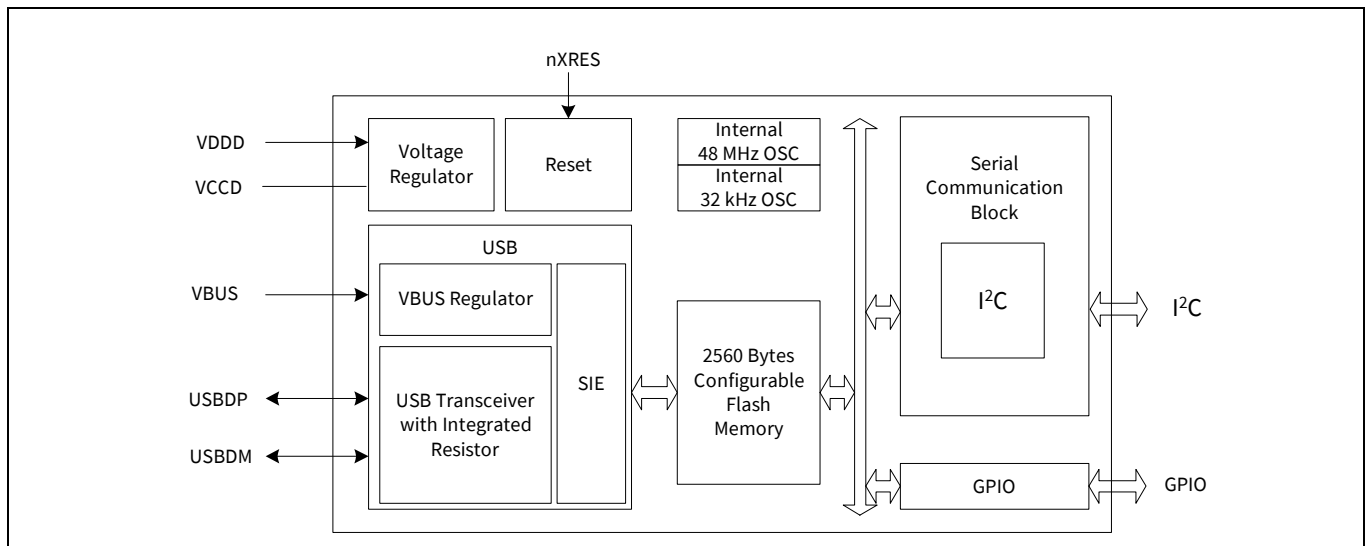

Block diagram - CY7C65217/CY7C65217A

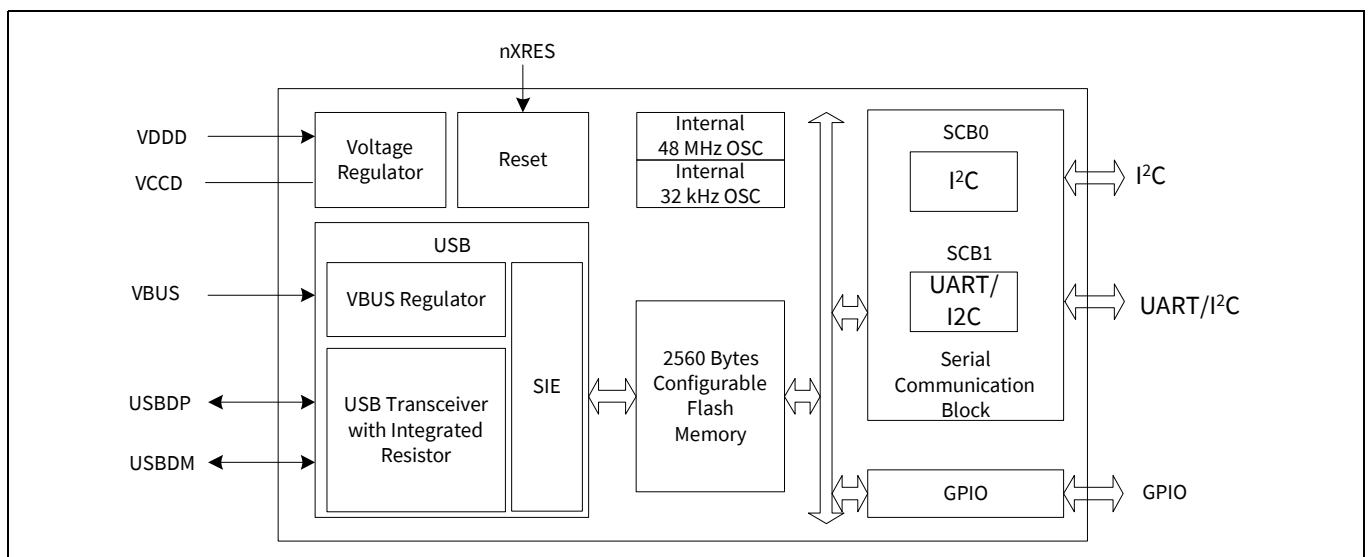

Table of contents

Features	1
Applications	2
Block diagram – CY7C65210/CY7C65210A	2
Block diagram – CY7C65217/CY7C65217A	2
Table of contents	3
1 Functional description	4
1.1 Comparison of Billboard parts.....	4
2 Pin description – CY7C65210/CY7C65210A	5
3 Pin description – CY7C65217/CY7C65217A	7
4 GPIO configuration	9
5 Functional overview	10
5.1 USB and Billboard device functionality.....	10
5.1.1 USB	10
5.1.2 Billboard device functionality	10
5.2 Serial communication	10
5.2.1 I2C interface	10
5.3 UART interface	10
5.4 GPIO interface	11
5.5 Memory.....	11
5.6 System resources.....	11
5.6.1 Power system.....	11
5.6.2 Clock system	11
5.6.3 Internal 48 MHz oscillator	11
5.6.4 Internal 32 kHz oscillator.....	11
5.6.5 Reset.....	11
5.7 Suspend and Resume	11
5.8 Wakeup.....	11
5.9 Internal flash configuration.....	12
6 Electrical specifications	16
6.1 Absolute maximum ratings	16
6.2 Operating conditions.....	16
6.3 Device-level specifications	17
6.4 GPIO	19
6.5 nXRES.....	21
6.6 UART specifications	21
6.7 I2C specifications	21
6.8 Flash Memory specifications	21
7 Application schematic	22
8 Ordering information	24
8.1 Ordering code definitions.....	24
9 Packaging information	25
10 Acronyms	26
11 More information	27
12 Document conventions	28
12.1 Units of measure	28
Revision history	29

1 Functional description

CY7C6521x^[1] is a Full-speed USB controller, which enumerates as a Billboard device. It integrates a voltage regulator, an oscillator, and flash memory for storing configuration parameters, offering a cost-effective solution. CY7C6521x supports bus-powered mode and enables efficient system power management with suspend and remote wake-up signals. It is available in a 24-pin QFN package.

For a complete list of related resources, click [here](#).

1.1 Comparison of Billboard parts

Table 1 Comparison of Billboard parts

Feature	CY7C65210	CY7C65217	CY7C65210A	CY7C65217A
Billboard spec	1.1	1.1	1.21	1.21
Number of GPIOs	9	7	11	9
Suspend/Wakeup support	Yes	Yes	No ^[2]	No ^[2]

Notes

1. CY7C6521x refers to CY7C65210, CY7C65217, CY7C65210A, and CY7C65217A.
2. Because these features are not relevant to Billboard, support for these features is removed.

2 Pin description – CY7C65210/CY7C65210A

Table 2 Pin description – CY7C65210/CY7C65210A

Pin ^[3]	Type	Name	Default	Description
1	GPIO	GPIO_6	Tristate	GPIO
2	GPIO	GPIO_7	Tristate	GPIO
3	Power	VSSD	–	Digital ground
4	GPIO	GPIO_8	Tristate	GPIO
5	GPIO	GPIO_9	Tristate	GPIO
6	GPIO	GPIO_10	Tristate	GPIO
7	GPIO	GPIO_11	POWER#	GPIO (CY7C65210)
	GPIO	GPIO_11	Tristate	GPIO (CY7C65210A)
8	Output	SUSPEND	–	On CY7C65210, this pin indicates that the device in Suspend mode. Can be configured as active LOW/HIGH using the configuration utility.
	GPIO	GPIO_12	Tristate	On CY7C65210A, this pin serves as GPIO
9	Input	WAKEUP	–	On CY7C65210, this pin is configured to wake up the device from Suspend mode. Can be configured as active LOW/HIGH using the configuration utility.
	GPIO	GPIO_13	Tristate	On CY7C65210A, this pin serves as GPIO
10	USBIO	USBDP	–	USB Data signal plus, integrates termination resistor and a 1.5 kΩ pull-up resistor
11	USBIO	USBDM	–	USB Data signal minus, integrates termination resistor

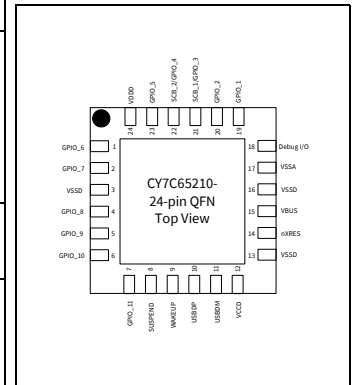

Note

3. Any pin acting as an input pin should not be left unconnected.

Pin description – CY7C65210/CY7C65210A

Table 2 Pin description – CY7C65210/CY7C65210A (continued)

Pin ^[3]	Type	Name	Default	Description
12	Power	VCCD	–	This pin should be decoupled to ground using a 1 μ F capacitor or by connecting a 1.8 V supply.
13	Power	VSSD	–	Digital ground
14	nXRES	nXRES	–	Chip reset, active LOW. Can be left unconnected or have a pull-up resistor connected if not used.
15	Power	VBUS	–	VBUS supply, 3.15 V to 5.25 V
16	Power	VSSD	–	Digital ground
17	Power	VSSA	–	Analog ground
18	Input	Debug I/O	–	Used for debug purpose. Should be left floating.
19	GPIO	GPIO_1	Input	Can be used as wakeup source to wakeup device from Suspend mode.
20	GPIO	GPIO_2	Tristate	GPIO
21	SCB/GPIO	SCB_1/ GPIO_3	SCL	I ² C SCL
22	SCB/GPIO	SCB_2/ GPIO_4	SDA	I ² C SDA
23	GPIO	GPIO_5	Tristate	GPIO
24	Power	VDDD	–	Supply to the device core and Interface, 1.71 V to 5.5 V

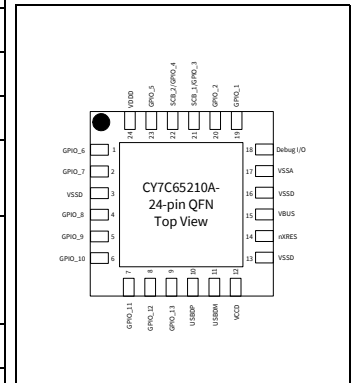

Note

3. Any pin acting as an input pin should not be left unconnected.

3 Pin description – CY7C65217/CY7C65217A

Table 3 Pin description – CY7C65217/CY7C65217A

Pin ^[4]	Type	Name	Default	Description
1	GPIO	GPIO_6	Tristate	GPIO
2	GPIO	GPIO_7	Tristate	GPIO
3	Power	VSSD	–	Digital ground
4	SCB/GPIO	SCB1_0/ GPIO_8	RXD	UART RXD/I ² C SCL
5	SCB/GPIO	SCB1_1/ GPIO_9	TXD	UART TXD/I ² C SDA
6	GPIO	GPIO_10	Tristate	GPIO
7	GPIO	GPIO_11	POWER#	GPIO (CY7C65217)
	GPIO	GPIO_11	Tristate	GPIO (CY7C65217A)
8	Output	SUSPEND	–	On CY7C65217, this pin indicates that the device in Suspend mode. Can be configured as active LOW/HIGH using the configuration utility.
	GPIO	GPIO_12	Tristate	GPIO
9	Input	WAKEUP	–	On CY7C65217, this pin is configured to wake up the device from Suspend mode. Can be configured as active LOW/HIGH using the configuration utility.
	GPIO	GPIO_13	Tristate	On CY7C65217A, this pin serves as GPIO
10	USBIO	USBDP	–	USB Data signal plus, integrates termination resistor and a 1.5-kΩ pull-up resistor
11	USBIO	USBDM	–	USB Data signal minus, integrates termination resistor

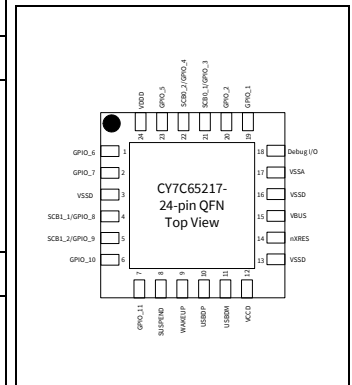

Note

4. Any pin acting as an input pin should not be left unconnected.

Table 3 Pin description – CY7C65217/CY7C65217A (continued)

Pin ^[4]	Type	Name	Default	Description
12	Power	VCCD	–	This pin should be decoupled to ground using a 1 μ F capacitor or by connecting a 1.8 V supply.
13	Power	VSSD	–	Digital ground
14	nXRES	nXRES	–	Chip reset, active LOW. Can be left unconnected or have a pull-up resistor connected if not used.
15	Power	VBUS	–	VBUS supply, 3.15 V to 5.25 V
16	Power	VSSD	–	Digital ground
17	Power	VSSA	–	Analog ground
18	Input	Debug I/O	–	Used for debug purpose. Should be left floating
19	GPIO	GPIO_1	Input	Can be used as wakeup source to wakeup device from Suspend mode
20	GPIO	GPIO_2	Tristate	GPIO
21	SCB/GPIO	SCB0_1/ GPIO_3	SCL	SCB0 I ² C SCL
22	SCB/GPIO	SCB0_2/ GPIO_4	SDA	SCB0 I ² C SDA
23	GPIO	GPIO_5	Tristate	GPIO
24	Power	VDDD	–	Supply to the device core and Interface, 1.71 V to 5.5 V

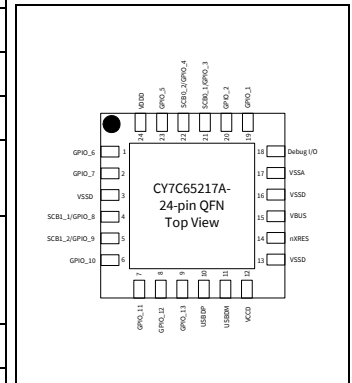

Note

4. Any pin acting as an input pin should not be left unconnected.

4 GPIO configuration

Table 4 GPIO configuration

GPIO configuration option	Description
INPUT	Input GPIO
POWER#	This active low output signal is used to control power to an external logic through a switch to cut power off during an Unconfigured USB device and USB suspend. 0 - USB device in Configured state 1 - USB device in Unconfigured state or during USB suspend mode Note: CY7C65210A and CY7C65217A do not support POWER#.
TRISTATE	I/O Tristated (Open-Drain)
OUTPUT	Drive LOW or HIGH

5 Functional overview

5.1 USB and Billboard device functionality

5.1.1 USB

CY7C6521x has a built-in USB 2.0 Full-Speed transceiver. The transceiver incorporates the internal USB series termination resistors on the USB data lines and a 1.5 k Ω pull-up resistor on USBDP.

5.1.2 Billboard device functionality

CY7C6521x is used to communicate Alternate Modes supported by a Device Container to a USB Host system. CY7C6521x sends this information through BOS descriptor and string descriptors in human-readable format. CY7C6521x supports the Billboard descriptor as part of the complete BOS descriptor. The CY7C65210/65217 supports USB Billboard Device class Rev. 1.1 while the CY7C65210A/65217A supports USB Billboard Device class Rev. 1.21. For further details on the device class, refer to the [USB Billboard Device Class specification](#).

5.2 Serial communication

CY7C65210 and CY7C65210A have one Serial Communication Block (SCB) whereas CY7C65217 and CY7C65217A have two SCBs that implement either UART or I²C interface.

5.2.1 I²C interface

The I²C interface implements full multi-master mode and supports up to 400 kHz. For further details on the protocol, refer to the NXP I²C specification, Rev. 5.

Notes:

- I²C ports are not tolerant to higher voltages. Therefore, they cannot be hot-swapped or powered up independently when chip is not powered.
- The minimum fall time of the SCL is met (as per NXP I²C specification rev. 5) when V_{DD} is between 1.71 V and 3.0 V. When V_{DD} is within the range of 3.0 V to 3.6 V, it is recommended to add a 50 pF capacitor on the SCL signal.

5.3 UART interface

Only the SCB1 interface of CY7C65217 and CY7C65217A can be configured as a UART interface.

The 2-pin UART interface (RXD and TXD) provides asynchronous serial communication with other UART devices operating at speeds of up to 115200. It supports seven or eight data bits, one or two stop bits, odd, even, mark, space, and no parity. The UART interface supports full-duplex communication with a signaling format that is compatible with the standard UART protocol. The UART pins may be interfaced to industry-standard RS-232/RS-422 transceivers to manage different voltage levels. Common UART functions, such as parity error^[5] and frame error^[6], are supported. The UART parameters can be set using native APIs.

Notes

5. Parity error gets detected when UART transmitter device is configured for odd parity and UART receiver device is configured for even parity.
6. Frame error gets detected when UART transmitter device is configured for 7 bits data width and 1 stop bit, whereas UART receiver device is configured for 8 bit data width and 2 stop bits.

5.4 GPIO interface

CY7C65210 has nine configurable GPIOs whereas CY7C65217 has seven configurable GPIOs. CY7C65210A has eleven configurable GPIOs whereas CY7C65217A has nine configurable GPIOs.

The configurable options are as follows:

- INPUT: Input GPIO
- POWER#: Power control
- TRISTATE: I/O tristated
- OUTPUT: Drive LOW or HIGH

5.5 Memory

CY7C6521x has a 2560 bytes configurable flash. Flash is used to store USB parameters such as VID/PID, serial number, product and manufacturer descriptors, and Billboard Device Class-specific descriptors.

5.6 System resources

5.6.1 Power system

CY7C6521x supports USB Suspend mode to control power usage. CY7C6521x operates in bus-powered or self-powered modes over a range of 3.15 V to 5.5 V.

5.6.2 Clock system

CY7C6521x has a fully integrated clock with no external components required. The clock system is responsible for providing clocks to all subsystems.

5.6.3 Internal 48 MHz oscillator

The internal 48-MHz oscillator is the primary source of internal clocking in CY7C6521x.

5.6.4 Internal 32 kHz oscillator

The internal 32-kHz oscillator is primarily used to generate clocks for peripheral operation in USB Suspend mode.

5.6.5 Reset

The reset block provides reliable power-on reset and brings the device back to the default known state. The nXRES (active LOW) pin can be used by the external devices to reset CY7C6521x.

5.7 Suspend and Resume

The CY7C65210 and CY7C65217 device asserts the SUSPEND pin when the USB bus enters the suspend state. This helps in meeting the stringent suspend current requirement of the USB 2.0 specification, while using the device in bus-powered mode. The device resumes from the suspend state under either of the two following conditions:

- Any activity is detected on the USB bus
- The WAKEUP pin is asserted to generate remote wakeup to the host

5.8 Wakeup

The WAKEUP pin on CY7C65210 and CY7C65217 is used to generate the remote wakeup signal on the USB bus. The remote wakeup signal is sent only if the host enables this feature through the SET_FEATURE request. The device communicates support for the remote wakeup to the host through the configuration descriptor during the USB enumeration process.

5.9 Internal flash configuration

The internal flash memory can be used to store the configuration parameters provided in [Table 5](#).

Table 5 Internal flash configuration for CY7C65210/CY7C65210A

Parameter	Default value	Description
USB configuration		
USB Vendor ID (VID)	0x04B4	Default Cypress VID. Can be configured to customer VID.
USB Product ID (PID)	0x5210	Default Cypress PID. Can be configured to customer PID.
Manufacturer string	Infineon Technologies Semiconductor	Can be configured with any string up-to 126 characters ^[7]
Product string	Billboard device	Can be configured with any string up-to 126 characters ^[7]
Serial string	User-defined	Can be configured with any string up-to 126 characters ^[7] . If the serial string is not configured by the user, a unique serial number will be generated using the wafer die parameters.
Power mode	Bus powered	Can be configured to bus-powered or self-powered mode
Max current draw	100 mA	Can be configured to any value from 0 to 500 mA. The configuration descriptor will be updated based on this
Remote wakeup	Enabled	Can be disabled on CY7C65210. Remote wakeup is initiated by asserting the WAKEUP or GPIO_1 pin
	Disabled	On CY7C65210A, this feature is removed.
bcdDevice	0x00	Can be configured with specific binary coded decimal number

Notes

7. Maximum available configuration space for all string descriptors is 1920 bytes. Each string descriptor can be configured up to 126 characters.
8. These GPIOs are available only on CY7C65210A.

Functional overview

Table 5 Internal flash configuration for CY7C65210/CY7C65210A (continued)

Parameter	Default value	Description
GPIO configuration		
GPIO_1	Input	GPIO can be configured as shown in “GPIO configuration” on page 9
GPIO_2	Tristate	
GPIO_3	I ² C SCL	
GPIO_4	I ² C SDA	
GPIO_5	Tristate	
GPIO_6	Tristate	
GPIO_7	Tristate	
GPIO_8	Tristate	
GPIO_9	Tristate	
GPIO_10	Tristate	
GPIO_11	Power# (CY7C65210)	
	Tristate (CY7C65210A)	
GPIO_12	Tristate ^[8]	
GPIO_13	Tristate ^[8]	
Billboard device class descriptor configuration		
iAdditionalInfoURL	USB-C Power Delivery Controllers	Can be configured with any string up-to 126 characters ^[7]
bNumberOfAlternateModes	0x01	Can be configured with any value from 0x01 to 0x08
bPreferredAlternateMode	0x00	Can be configured with any value from 0x00 to 0x07
VCONN Power	0x0000	Can be configured with any value from 0x0000 to 0x0006 or it can be configured with value 0x8000
SVID	0xFF01	Can be configured to specific SVID
bAlternateMode	0x01	Can be configured with any value from 0x01 to 0x08
iAlternateModeString	Type-C to Display adapter. For further assistance, see https://help.vesa.org/dp-usb-type-c	Can be configured with any string up-to 126 characters ^[7]
dwAlternateModeVdo	0x000C00C5	Can be configured with any 4-byte value (applicable only for CY7C65210A/CY7C65217A)

Notes

7. Maximum available configuration space for all string descriptors is 1920 bytes. Each string descriptor can be configured up to 126 characters.
8. These GPIOs are available only on CY7C65210A.

Table 6 Internal Flash configuration for CY7C65217/CY7C65217A

Parameter	Default value	Description
USB configuration		
USB Vendor ID (VID)	0x04B4	Default Infineon VID. Can be configured to customer VID
USB Product ID (PID)	0x5217	Default Infineon PID. Can be configured to customer PID
Manufacturer string	Infineon Technologies Semiconductor	Can be configured with any string up-to 126 characters ^[9]
Product string	Billboard device	Can be configured with any string up-to 126 characters ^[9]
Serial string	User-defined	Can be configured with any string up-to 126 characters ^[9] . If the Serial string is not configured by the user then a unique serial number will be generated using the wafer die parameters.
Power mode	Bus powered	Can be configured to bus-powered or self-powered mode
Max current draw	100 mA	Can be configured to any value from 0 to 500 mA. The configuration descriptor will be updated based on this
Remote wakeup	Enabled	Can be disabled on CY7C65217. Remote wakeup is initiated by asserting the WAKEUP or GPIO_1 pin.
	Disabled	On CY7C65217A, this feature is removed
bcdDevice	0x00	Can be configured with specific binary coded decimal number

Notes

9. Maximum available configuration space for all string descriptors is 1920 bytes. Each string descriptor can be configured up to 126 characters.

10. These GPIOs are available only on CY7C65217A.

Table 6 Internal Flash configuration for CY7C65217/CY7C65217A (continued)

Parameter	Default value	Description
GPIO configuration		
GPIO_1	Input	GPIO can be configured as shown in Table 4
GPIO_2	Tristate	
GPIO_3	SCB0 I ² C SCL	
GPIO_4	SCB0 I ² C SDA	
GPIO_5	Tristate	
GPIO_6	Tristate	
GPIO_7	Tristate	
GPIO_8	SCB1 UART RXD	
GPIO_9	SCB1 UART TXD	
GPIO_10	Tristate	
GPIO_11	Power#(CY7C65217)	
	Tristate(CY7C65217A)	
GPIO_12	Tristate ^[10]	
GPIO_13	Tristate ^[10]	
Billboard device class descriptor configuration		
iAdditionalInfoURL	USB-C Power Delivery Controllers	Can be configured with any string up-to 126 characters ^[9]
bNumberOfAlternate-Modes	0x01	Can be configured with any value from 0x01 to 0x08
bPreferredAlternateMode	0x00	Can be configured with any value from 0x00 to 0x07
VCONN Power	0x0000	Can be configured with any value from 0x0000 to 0x0006 or it can be configured with value 0x8000
SVID	0xFF01	Can be configured to specific SVID
bAlternateMode	0x01	Can be configured with any value from 0x01 to 0x08
iAlternateModeString	Type-C to Display adapter. For further assistance, see https://help.vesa.org/dp-usb-type-c	Can be configured with any string up-to 126 characters ^[9]
dwAlternateModeVdo	0x000C00C5	Can be configured with any 4-byte value (applicable only for CY7C65210A and CY7C65217A)

Notes

- Maximum available configuration space for all string descriptors is 1920 bytes. Each string descriptor can be configured up to 126 characters.
- These GPIOs are available only on CY7C65217A.

6 Electrical specifications

6.1 Absolute maximum ratings

Exceeding maximum ratings^[11] may shorten the useful life of the device.

Table 7 Absolute maximum ratings

Parameter	Maximum ratings
Storage temperature (Industrial, commercial)	-55°C to +100°C
Storage temperature (Automotive)	-55°C to +150°C
Ambient temperature with power supplied (Industrial, commercial)	-40°C to +85°C
Ambient temperature with power supplied (Automotive)	-40°C to +105°C
Supply voltage to ground potential	
V_{DDD}	6.0 V
V_{BUS}	6.0 V
V_{CCD}	1.95 V
V_{GPIO}	$V_{DDD} + 0.5$ V
Static discharge voltage ESD protection levels:	
HBM per JESD22-A114	2.2-kV
Latch-up current	140 mA
Current per GPIO	25 mA

6.2 Operating conditions

Table 8 Operating conditions

Parameter	Operating conditions
T_A (ambient temperature under bias)	
Commercial	0°C to 70°C
Industrial	-40°C to +85°C
Automotive	-40°C to +105°C
V_{BUS} supply voltage	3.15 V to 5.50 V
V_{DDD} supply voltage	1.71 V to 5.50 V
V_{CCD} supply voltage	1.71 V to 1.89 V

Note

11. Usage above the Absolute Maximum conditions may cause permanent damage to the device. Exposure to Absolute Maximum conditions for extended periods of time may affect device reliability. When used below Absolute Maximum conditions but above normal operating conditions, the device may not operate to specification.

6.3 Device-level specifications

Table 9 DC specifications

Parameter	Description	Min	Typ	Max	Unit	Details/conditions
V _{BUS}	V _{BUS} supply voltage	3.15	3.30	3.45	V	Set and configure the correct voltage range using a configuration utility for V _{BUS} . Default 5 V
		4.35	5.00	5.5	V	
V _{DDD}	V _{DDD} supply voltage	1.71	1.80	1.89	V	Used to set I/O and core voltage. Set and configure the correct voltage range using a configuration utility for V _{DDD} . Default 3.3 V
		2.0	3.3	5.5	V	
V _{CCD}	Output voltage (for core logic)	–	1.80	–	V	Do not use this supply to drive the external device. <ul style="list-style-type: none"> • 1.71 V ≤ V_{DDD} ≤ 1.89 V: Short the V_{CCD} pin with the V_{DDD} pin • V_{DDD} > 2 V – Connect a 1-μF capacitor (C_{efc}) between the V_{CCD} pin and ground
C _{efc}	External regulator voltage bypass	1.00	1.30	1.60	μF	X5R ceramic or better
I _{DD1}	Operating supply current	–	20	–	mA	USB 2.0 FS, UART at 1-Mbps single channel, no GPIO switching
I _{DD2}	USB suspend supply current	–	5	–	μA	Does not include current through a pull-up resistor on USB _{DP}

Electrical specifications

Table 10 AC specifications

Parameter	Description	Min	Typ	Max	Unit	Details/conditions
Fall Time_FS	FS USB fall Time	-	7.815	-	ns	90% to 10% of full swing, 50 pF load
Rise Time_FS	FS USB rise Time	-	8.367	-	ns	10% to 90% of full swing, 50 pF load
TRFM_FS	FS rise/fall matching	-	107.024	-	%	-
VCRS_FS	FS crossover voltage	-	1.797	-	V	-
TDJ1	FS driver jitter (next)	-	-0.339	-	ns	-
TDJ2	FS driver jitter (paired)	-	-0.285	-	ns	-
TFDEOP	FS differential to EOP Skew	-	-0.076	-	ns	-
F1	Frequency	47.04	48	48.96	MHz	Non-USB mode
F2		47.88	48	48.12	MHz	USB mode
Zout	USB driver output impedance	28	-	44	W	-
Twakeup	Wakeup from USB Suspend mode	-	25	-	μs	-

Electrical specifications

6.4 GPIO
Table 11 GPIO DC specification

Parameter	Description	Min	Typ	Max	Unit	Details/conditions
$V_{IH}^{[12]}$	Input voltage HIGH threshold	$0.7 \times V_{DDD}$	–	–	V	CMOS Input
V_{IL}	Input voltage LOW threshold	–	–	$0.3 \times V_{DDD}$	V	CMOS Input
$V_{IH}^{[12]}$	LVTTL input, $V_{DDD} < 2.7\text{ V}$	$0.7 \times V_{DDD}$	–	–	V	–
V_{IL}	LVTTL input, $V_{DDD} < 2.7\text{ V}$	–	–	$0.3 \times V_{DDD}$	V	–
$V_{IH}^{[12]}$	LVTTL input, $V_{DDD} \geq 2.7\text{ V}$	2	–	–	V	–
V_{IL}	LVTTL input, $V_{DDD} \geq 2.7\text{ V}$	–	–	0.8	V	–
V_{OH}	CMOS output voltage HIGH level	$V_{DDD} - 0.4$	–	–	V	$I_{OH} = 4\text{ mA}$, $V_{DDD} = 5\text{ V} \pm 10\%$
V_{OH}	CMOS output voltage HIGH level	$V_{DDD} - 0.6$	–	–	V	$I_{OH} = 4\text{ mA}$, $V_{DDD} = 3.3\text{ V} \pm 10\%$
V_{OH}	CMOS output voltage HIGH level	$V_{DDD} - 0.5$	–	–	V	$I_{OH} = 1\text{ mA}$, $V_{DDD} = 1.8\text{ V} \pm 5\%$
V_{OL}	CMOS output voltage LOW level	–	–	0.4	V	$I_{OL} = 8\text{ mA}$, $V_{DDD} = 5\text{ V} \pm 10\%$
V_{OL}	CMOS output voltage LOW level	–	–	0.6	V	$I_{OL} = 8\text{ mA}$, $V_{DDD} = 3.3\text{ V} \pm 10\%$
V_{OL}	CMOS output voltage LOW level	–	–	0.6	V	$I_{OL} = 4\text{ mA}$, $V_{DDD} = 1.8\text{ V} \pm 5\%$
Rpullup	Pull-up resistor	3.5	5.6	8.5	k Ω	–
Rpulldown	Pull-down resistor	3.5	5.6	8.5	k Ω	–
I_{IL}	Input leakage current (absolute value)	–	–	2	nA	25°C, $V_{DDD} = 3.0\text{ V}$
C_{IN}	Input capacitance	–	–	7	pF	–
Vhystttl	Input hysteresis LVTTL; $V_{DDD} > 2.7\text{ V}$	25	40	C	mV	–
Vhyscmos	Input hysteresis CMOS	$0.05 \times V_{DDD}$	–	–	mV	–

Note

 12. V_{IH} must not exceed $V_{DDD} + 0.2\text{ V}$.

Electrical specifications

Table 12 GPIO AC specifications

Parameter	Description	Min	Typ	Max	Unit	Details/conditions
T _{RiseFast1}	Rise Time in Fast mode	2	–	12	ns	V _{DDD} = 3.3 V/ 5.5 V, Cload = 25 pF
T _{FallFast1}	Fall Time in Fast mode	2	–	12	ns	V _{DDD} = 3.3 V/ 5.5 V, Cload = 25 pF
T _{RiseSlow1}	Rise Time in Slow mode	10	–	60	ns	V _{DDD} = 3.3 V/ 5.5 V, Cload = 25 pF
T _{FallSlow1}	Fall Time in Slow mode	10	–	60	ns	V _{DDD} = 3.3 V/ 5.5 V, Cload = 25 pF
T _{RiseFast2}	Rise Time in Fast mode	2	–	20	ns	V _{DDD} = 1.8 V, Cload = 25 pF
T _{FallFast2}	Fall Time in Fast mode	20	–	100	ns	V _{DDD} = 1.8 V, Cload = 25 pF
T _{RiseSlow2}	Rise Time in Slow mode	2	–	20	ns	V _{DDD} = 1.8 V, Cload = 25 pF
T _{FallSlow2}	Fall Time in Slow mode	20	–	100	ns	V _{DDD} = 1.8 V, Cload = 25 pF

Electrical specifications

6.5 nXRES

Table 13 nXRES DC specifications

Parameter	Description	Min	Typ	Max	Unit	Details/conditions
V _{IH}	Input voltage HIGH threshold	0.7 × V _{DDD}	–	–	V	–
V _{IL}	Input voltage LOW threshold	–	–	0.3 × V _{DDD}	V	–
R _{pullup}	Pull-up resistor	3.5	5.6	8.5	kΩ	–
C _{IN}	Input capacitance	–	5	–	pF	–
V _{hysxres}	Input voltage hysteresis	–	100	–	mV	–

Table 14 nXRES AC specifications

Parameter	Description	Min	Typ	Max	Unit	Details/conditions
Tresetwidth	Reset pulse width	1	–	–	μs	–

6.6 UART specifications

Table 15 UART AC specifications

Parameter	Description	Min	Typ	Max	Unit	Details/conditions
F _{UART}	UART bit rate	0.3	–	3000	kbps	Single SCB: TX + RX Dual SCB: TX or RX

6.7 I²C specifications

Table 16 I²C AC specifications

Parameter	Description	Min	Typ	Max	Unit	Details/conditions
F _{I2C}	I ² C frequency	1	–	400	kHz	–

6.8 Flash Memory specifications

Table 17 Flash Memory specifications

Parameter	Description	Min	Typ	Max	Unit	Details/conditions
Fend	Flash endurance	100K	–	–	cycles	–
Fret	Flash retention. T _A ≤ 85°C, 10K program/erase cycles	10	–	–	years	–

7 Application schematic

Figure 1 shows the application schematic for CY7C65210. See the [“Pin description – CY7C65210/CY7C65210A”](#) on page 5 for signal details.

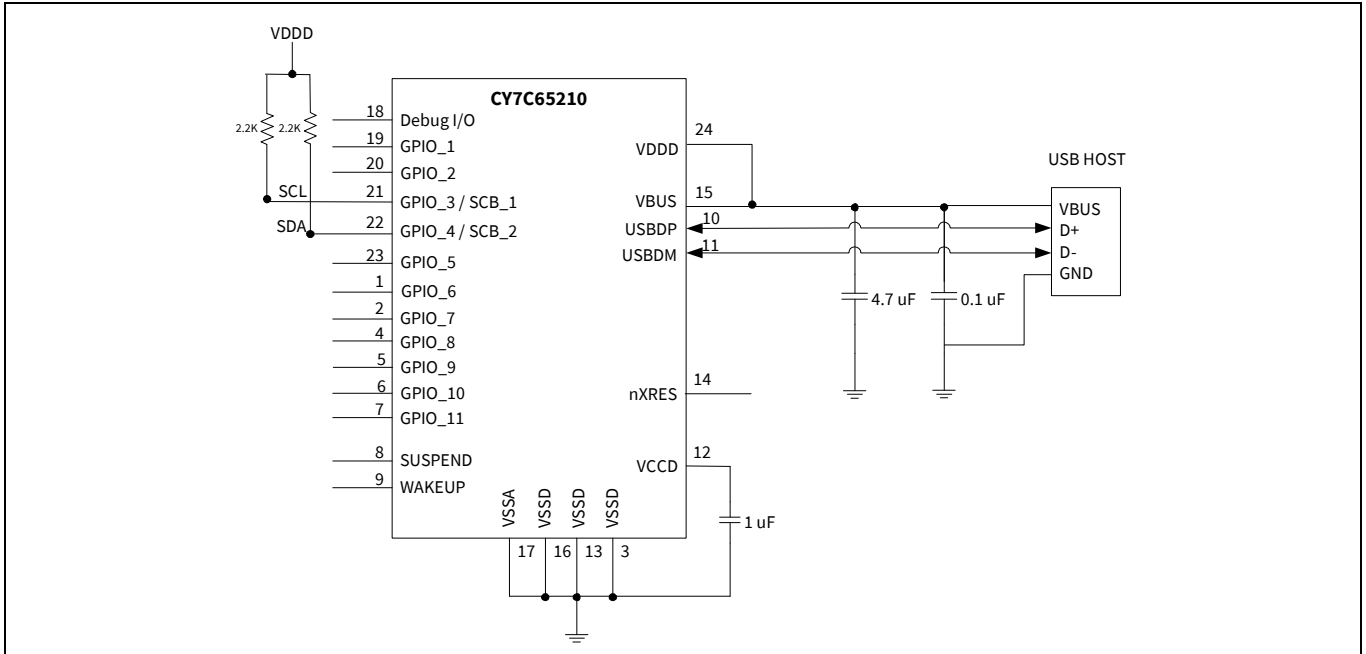

Figure 1 CY7C65210 application schematic

Figure 2 shows the application schematic for CY7C65210A. See the [“Pin description – CY7C65210/CY7C65210A”](#) on page 5 for signal details.

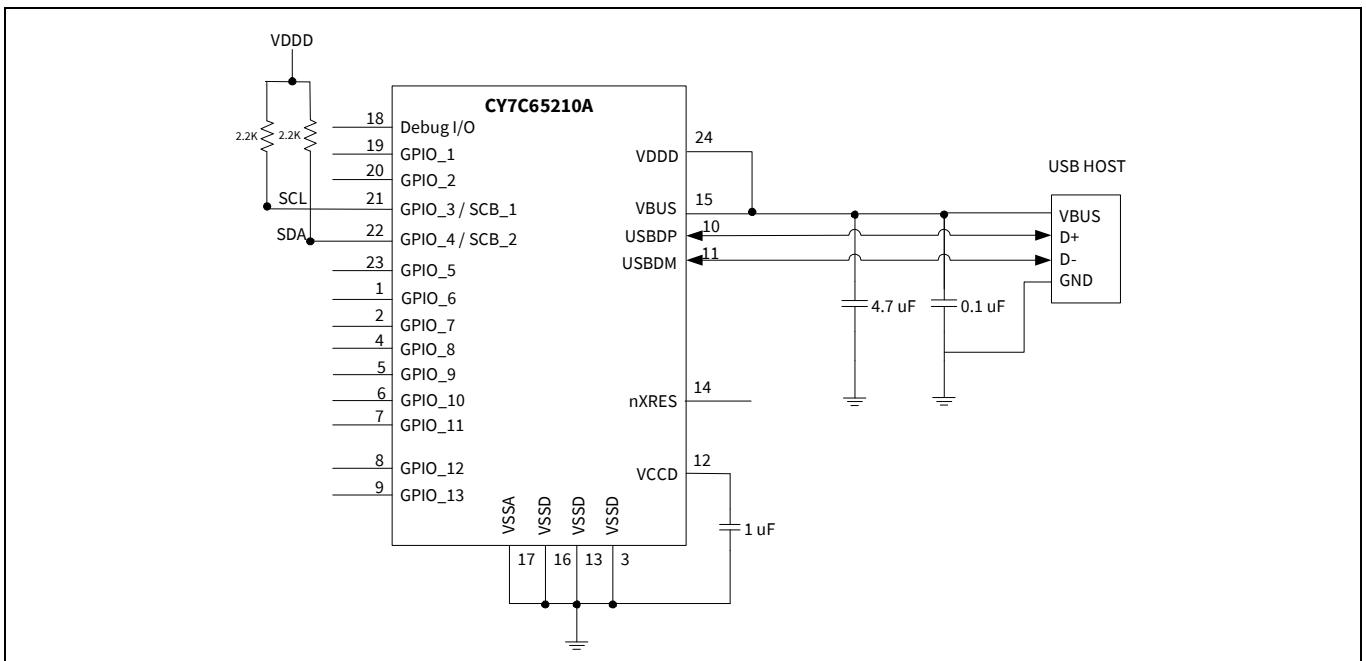

Figure 2 CY7C65210A application schematic

Application schematic

Figure 3 shows the application schematic for CY7C65217. See the **“Pin description – CY7C65217/CY7C65217A”** on page 7 for signal details.

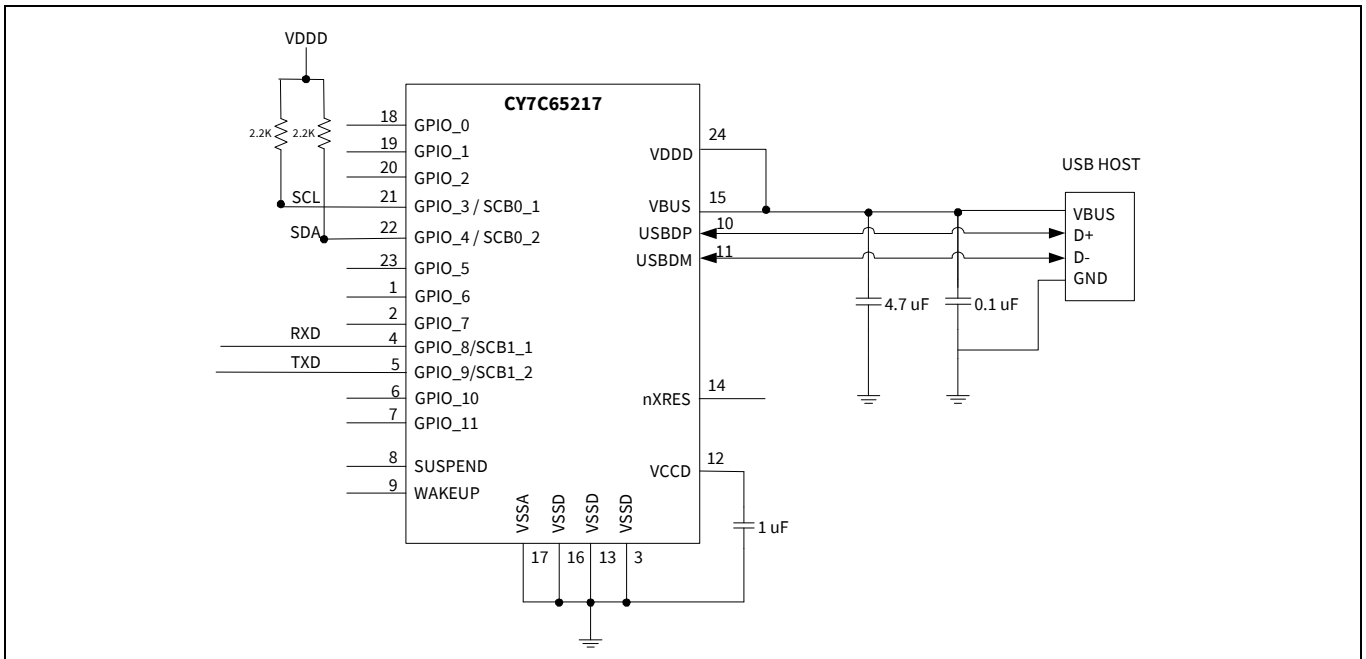

Figure 3 CY7C65217 application schematic

Figure 4 shows the application schematic for CY7C65217A. See the **“Pin description – CY7C65217/CY7C65217A”** on page 7 for signal details.

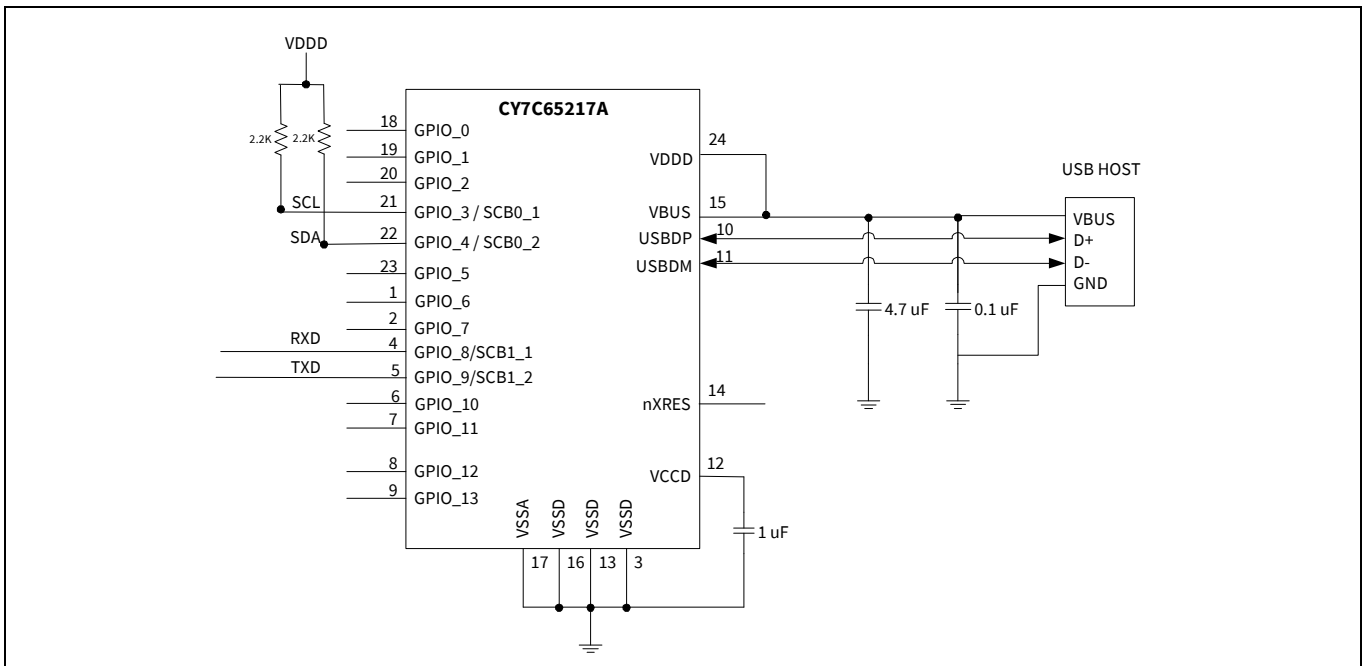

Figure 4 CY7C65217A application schematic

Ordering information

8 Ordering information

Table 18 lists the key package features and ordering codes of CY7C65210, CY7C65217, CY7C65210A, and CY7C65217A. For more information, contact your local sales representative.

Table 18 Key features and ordering information

Product	Package	Temperature range
CY7C65210-24LTXI	24-lead QFN (4.00 × 4.00 × 0.55 mm, 0.5 mm pitch) (Pb-free)	Industrial
CY7C65210-24LTXIT	24-lead QFN (4.00 × 4.00 × 0.55 mm, 0.5 mm pitch) (Pb-free) – tape and reel	Industrial
CY7C65210A-24LTXI	24-lead QFN (4.00 × 4.00 × 0.55 mm, 0.5 mm pitch) (Pb-free)	Industrial
CY7C65210A-24LTXIT	24-lead QFN (4.00 × 4.00 × 0.55 mm, 0.5 mm pitch) (Pb-free) – tape and reel	Industrial
CY7C65217-24LTXI	24-lead QFN (4.00 × 4.00 × 0.55 mm, 0.5 mm pitch) (Pb-free)	Industrial
CY7C65217-24LTXIT	24-lead QFN (4.00 × 4.00 × 0.55 mm, 0.5 mm pitch) (Pb-free) – tape and reel	Industrial
CY7C65217A-24LTXI	24-lead QFN (4.00 × 4.00 × 0.55 mm, 0.5 mm pitch) (Pb-free)	Industrial
CY7C65217A-24LTXIT	24-lead QFN (4.00 × 4.00 × 0.55 mm, 0.5 mm pitch) (Pb-free)	Industrial
CY7C65210A-24LQXS	24-lead QFN (4.00 × 4.00 × 0.55 mm, 0.5 mm pitch) (Pb-free)	Automotive
CY7C65210A-24LQXST	24-lead QFN (4.00 × 4.00 × 0.55 mm, 0.5 mm pitch) (Pb-free) – tape and reel	Automotive

8.1 Ordering code definitions

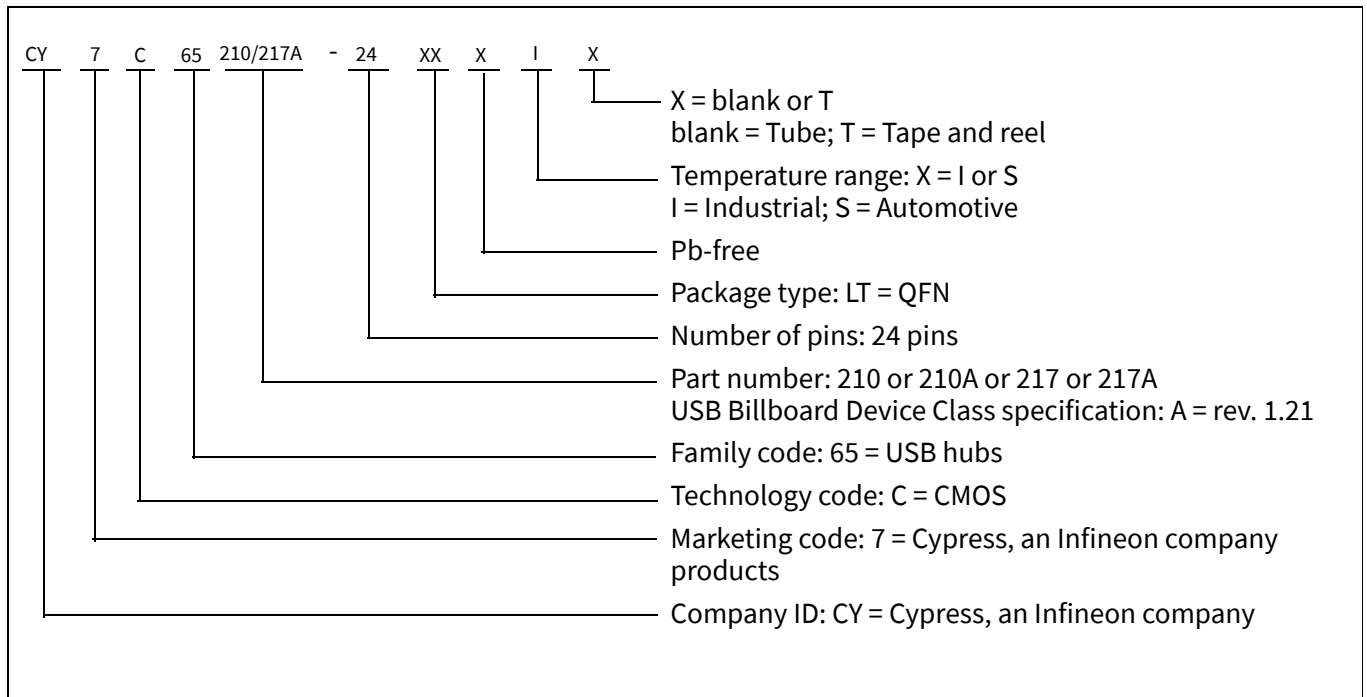

9 Packaging information

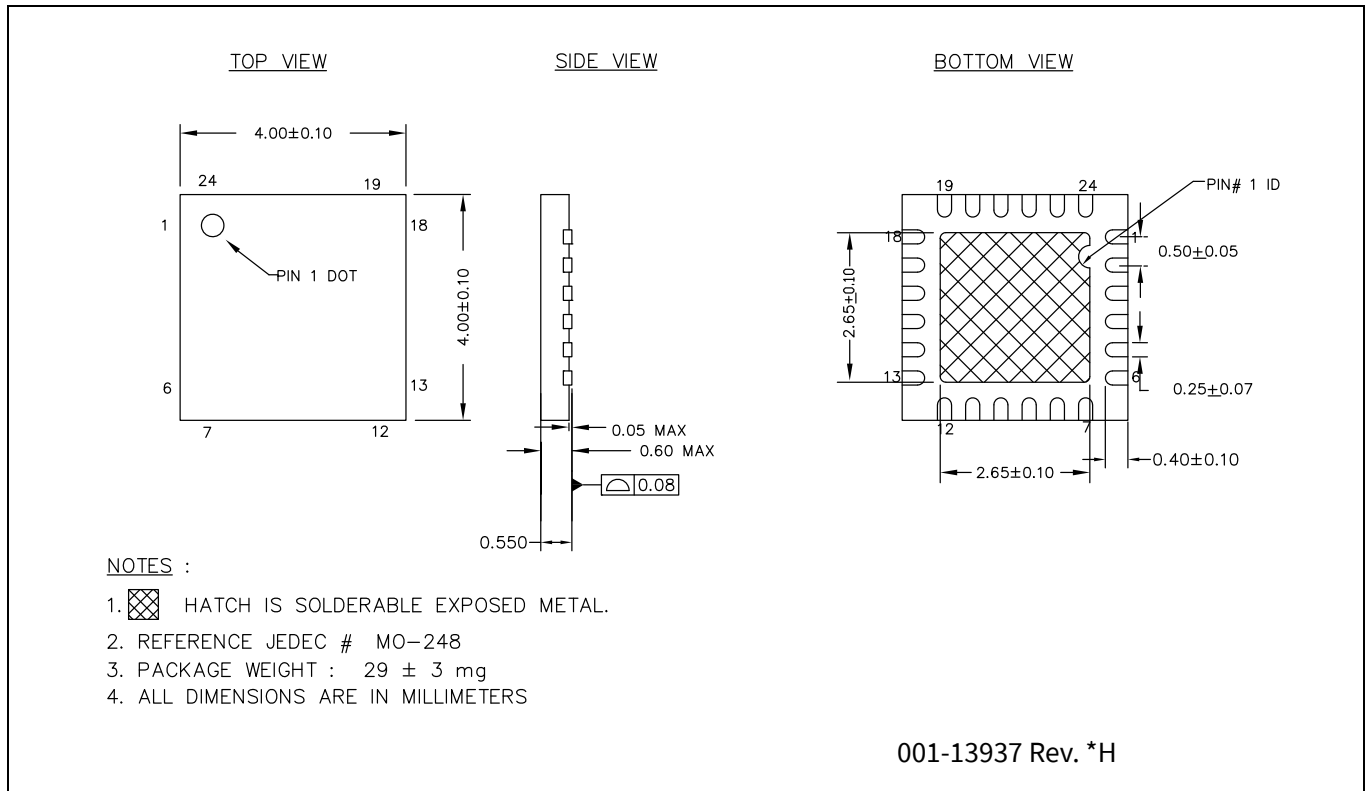

Figure 5 24-lead QFN ((4 × 4 × 0.6 mm) LQ24A/LQ24B 2.65 × 2.65 E-Pad (Sawn)) package outline (PG-VQFN-24), 001-13937

Table 19 Package characteristics

Parameter	Description	Min	Typ	Max	Unit
T _A	Operating ambient temperature (Industrial)	-40	25	85	°C
T _A	Operating ambient temperature (Automotive)	-40	25	105	°C
THJ	Package θ _{JA}	-	18.4	-	°C/W
THJ	Package θ _{JC}	-	3.5	-	°C/W

Table 20 Solder reflow peak temperature

Package	Maximum peak temperature	Maximum time at peak temperature
24-pin QFN	260°C	30 s

Table 21 Package moisture sensitivity level (MSL), IPC/JEDEC J-STD-2

Package	MSL
24-pin QFN	MSL 3

10 Acronyms

Table 22 Acronyms used in this document

Acronym	Description
BOS	binary device object store
ESD	electrostatic discharge
GPIO	general purpose input/output
HBM	Human-body model
I ² C	inter-integrated circuit
MCU	microcontroller unit
OSC	oscillator
PID	product identification
SCB	Serial Communication block
SCL	I ² C serial clock
SDA	I ² C serial data
SIE	serial interface engine
SVID	standard or vendor ID
UART	Universal Asynchronous Receiver/Transmitter
USB	Universal Serial Bus
VID	Vendor Identification

More information

11 More information

Infineon provides a wealth of data at www.infineon.com to help you to select the right device for your design, and to help you to quickly and effectively integrate the device into your design.

- Overview: [USB portfolio](#), [USB roadmap](#)
- USB 2.0 product selectors: [USB 2.0 peripheral controllers](#), [EZ-USB™ serial bridge controller](#), [EZ-USB™ encore](#)
- Code Examples: [USB Full-Speed](#)
- Models: [IBIS](#)

12 Document conventions

12.1 Units of measure

Table 23 Units of measure

Symbol	Unit of measure
°C	degree celsius
DMIPS	Dhrystone million instructions per second
kΩ	kilo-ohm
KB	kilobyte
kHz	kilohertz
kV	kilovolt
Mbps	megabits per second
MHz	megahertz
mm	millimeter
V	volt

Revision history

Document revision	Date	Description of changes
**	2015-04-10	New data sheet.
*A	2015-07-22	<p>Updated Features: Replaced 10 with 9 under “General-purpose input/output (GPIO) pins”. Replaced “1536 bytes flash for storing configuration parameters” with “2560 bytes flash for storing configuration parameters”. Updated “Pin Description – CY7C65210”: Updated details corresponding to pins 18, 19, 21 and 22. Updated Functional overview: Updated GPIO interface: Updated description. Updated Memory: Updated description. Updated Internal flash configuration: Updated Table 5: Updated details corresponding to Serial string, and Remote wakeup parameters under “USB Configuration”. Removed GPIO_0 parameter and its details under “GPIO Configuration”. Updated details corresponding to iAdditionalInfoURL, and iAlternateModeString parameters under “Billboard Device class Descriptor Configuration”. Updated Packaging information: spec 001-13937 – Changed revision from *E to *F.</p>
*B	2015-08-13	<p>Updated Document Title to read as “CY7C65210/CY7C65217, USB Billboard Controller”. Added CY7C65217 part related information in all instances across the document. Replaced CY7C65210 with CY7C6521x in the required instances across the document. Updated Features: Updated details under “I²C interface”. Updated Functional description: Added Note 1 and referred the same note in CY7C6521x. Added “Block Diagram – CY7C65217”. Added “Pin Description – CY7C65217”. Updated Functional overview: Added UART interface. Updated Internal flash configuration: Updated Table 5: Updated details corresponding to GPIO_3, and GPIO_4 parameters under “GPIO Configuration”. Added Table 6. Updated Serial communication: Updated description. Updated GPIO interface: Updated description. Updated Application schematic: Added Figure 3. Updated Ordering information: Updated part numbers.</p>

Revision history

Document revision	Date	Description of changes
*C	2016-06-16	Updated Features : Updated details under “Driver support for Billboard Device”. Updated “Pin Description – CY7C65217”: No changes in detail. Removed all existing shades. Updated GPIO configuration : Added “TRISTATE” and “OUTPUT” options. Updated Functional overview : Updated USB and Billboard device functionality : Updated Billboard device functionality : Updated description. Updated UART interface : Added Note 5 and referred the same note in “parity error”. Added Note 6 and referred the same note in “frame error”. Updated GPIO interface : Updated description. Updated Internal flash configuration : Updated Table 6 : Updated details corresponding to GPIO_8 and GPIO_9 parameters under “GPIO Configuration”. Updated Electrical specifications : Added UART specifications . Updated Application schematic : Updated Figure 3 .
*D	2017-06-09	Updated Cypress Logo and Copyright.

Revision history

Document revision	Date	Description of changes
*E	2017-10-13	<p>Updated Document Title to read as “CY7C65210/CY7C65217/CY7C65210A/CY7C65217A, USB Billboard Controller”.</p> <p>Added CY7C65210A, CY7C65217A parts related information in all instances across the document.</p> <p>Updated Pin Description – CY7C65210/CY7C65210A: Replaced “CY7C65210” with “CY7C65210/CY7C65210A” in heading. Updated details corresponding to pins 7, 8 and 9.</p> <p>Updated Pin Description – CY7C65217/CY7C65217A: Replaced “CY7C65217” with “CY7C65217/CY7C65217A” in heading. Updated details corresponding to pins 7, 8 and 9.</p> <p>Updated GPIO configuration: Updated details in “Description” column corresponding to POWER# option.</p> <p>Updated Functional overview: Updated USB and Billboard device functionality: Updated Billboard device functionality: Updated description.</p> <p>Updated Internal flash configuration: Updated Table 5: Updated details corresponding to Serial string, and Remote wakeup parameters under “USB Configuration”.</p> <p>Updated details corresponding to GPIO_11 parameter under “GPIO Configuration”.</p> <p>Added GPIO_12, GPIO_13 parameters and their details under “GPIO Configuration”.</p> <p>Added dwAlternateModeVdo parameter and its details under “Billboard Device Class Descriptor Configuration”.</p> <p>Updated Table 6: Updated details corresponding to Serial string, and Remote wakeup parameters under “USB Configuration”.</p> <p>Updated details corresponding to GPIO_11 parameter under “GPIO Configuration”.</p> <p>Added GPIO_12, GPIO_13 parameters and their details under “GPIO Configuration”.</p> <p>Added dwAlternateModeVdo parameter and its details under “Billboard Device Class Descriptor Configuration”.</p> <p>Updated Application schematic: Added Figure 2. Added Figure 4.</p> <p>Updated Ordering information: Updated part numbers.</p>
*F	2018-04-02	<p>Updated to new template. Completing Sunset Review.</p>
*G	2024-05-07	<p>Added Automotive Temperature Range related information in all instances across the document.</p> <p>Updated Electrical specifications: Updated Operating conditions: Updated Table 8. Updated Device-level specifications: Removed description below heading.</p> <p>Updated Ordering information: Updated part numbers. Updated Ordering code definitions. Updated Packaging information: Spec 001-13937 – Changed revision from *F to *H.</p> <p>Migrated to Infineon template. Updated metadata. Completing Sunset Review.</p>

Revision history

Document revision	Date	Description of changes
*H	2024-09-09	Updated Packaging information: No change in revisions. Updated Table 19.

Trademarks

All referenced product or service names and trademarks are the property of their respective owners.

Edition 2024-09-09

Published by

**Infineon Technologies AG
81726 Munich, Germany**

**© 2024 Infineon Technologies AG.
All Rights Reserved.**

Do you have a question about this document?

Email:

erratum@infineon.com

Document reference

001-97082 Rev. *H

IMPORTANT NOTICE

The information given in this document shall in no event be regarded as a guarantee of conditions or characteristics ("Beschaffenheitsgarantie").

With respect to any examples, hints or any typical values stated herein and/or any information regarding the application of the product, Infineon Technologies hereby disclaims any and all warranties and liabilities of any kind, including without limitation warranties of non-infringement of intellectual property rights of any third party.

In addition, any information given in this document is subject to customer's compliance with its obligations stated in this document and any applicable legal requirements, norms and standards concerning customer's products and any use of the product of Infineon Technologies in customer's applications.

The data contained in this document is exclusively intended for technically trained staff. It is the responsibility of customer's technical departments to evaluate the suitability of the product for the intended application and the completeness of the product information given in this document with respect to such application.

WARNINGS

Due to technical requirements products may contain dangerous substances. For information on the types in question please contact your nearest Infineon Technologies office.

Except as otherwise explicitly approved by Infineon Technologies in a written document signed by authorized representatives of Infineon Technologies, Infineon Technologies' products may not be used in any applications where a failure of the product or any consequences of the use thereof can reasonably be expected to result in personal injury.