

XDPL8210 CDM10VD 35 W reference design with IPN80R900P7

For LED driver with isolated 0 to 10 V dimming and dim-to-off operation

Order code: REF-XDPL8210-U35W

About this document

Scope and purpose

This document is an engineering report for the XDPL8210 CDM10VD 35 W reference design (part ordering number: REF-XDPL8210-U35W; SP number: SP001886070), which uses Infineon's XDPL8210 High Power Factor (HPF) Flyback controller, CDM10VD isolated 0 to 10 V dimming interface IC and IPN80R900P7 MOSFET.

Intended audience

Power supply design engineers, field application engineers.

Table of contents

About this document	1
Table of contents	1
1 Introduction and safety information	2
2 Design features	3
3 Board specifications	4
4 Schematic and PCB layout	7
5 Performance	9
5.1 Non-dimming	9
5.1.1 Line and load regulation	9
5.1.2 System efficiency	10
5.1.3 Power Factor (PF) and Total Harmonic Distortion (iTHD)	10
5.1.4 Current harmonics	11
5.1.5 Thermal test	12
5.1.6 Conducted emissions (EN55015B).....	14
5.2 Dimming	16
5.2.1 Standby power	16
5.2.2 LED current dimming curve	17
5.2.3 PF and iTHD	18
5.3 Protections	18
5.3.1 Input UVP and maximum power limitation during brown-out	18
5.3.2 Input OVP	19
5.3.3 Adaptive output OVP	19
6 BOM and transformer specifications	21
7 References	24
Revision history	25

Introduction and safety information

1 Introduction and safety information

The XDPL8210 CDM10VD 35 W reference design is a digitally configurable HPF LED driver with universal AC input of 90 V_{rms} to 305 V_{rms}, wide output LED load range of 18 V to 54 V, and isolated 0 to 10 V dimming. It has a non-dimmed output current set-point of 830 mA and an output power limitation set-point of 35 W.

The 35 W reference design is ready to be tested out of the box, as shown in **Figure 1**. There is no need for any pre-programming by the user, as the XDPL8210 chip on the reference board has already been burned with the first full configuration set of working parameters.

A simple test set-up can be done by connecting the board's AC input (L – live, N – neutral) to the AC source, the board's output to the LEDs (+, -) and 0 to 10 V dimming input to the DC source, based on **Figure 1**.

Attention: *Lethal voltages are present on this reference design. Do not operate the board unless you are trained to handle high voltage circuits. Do not leave this board unattended when it is powered up.*

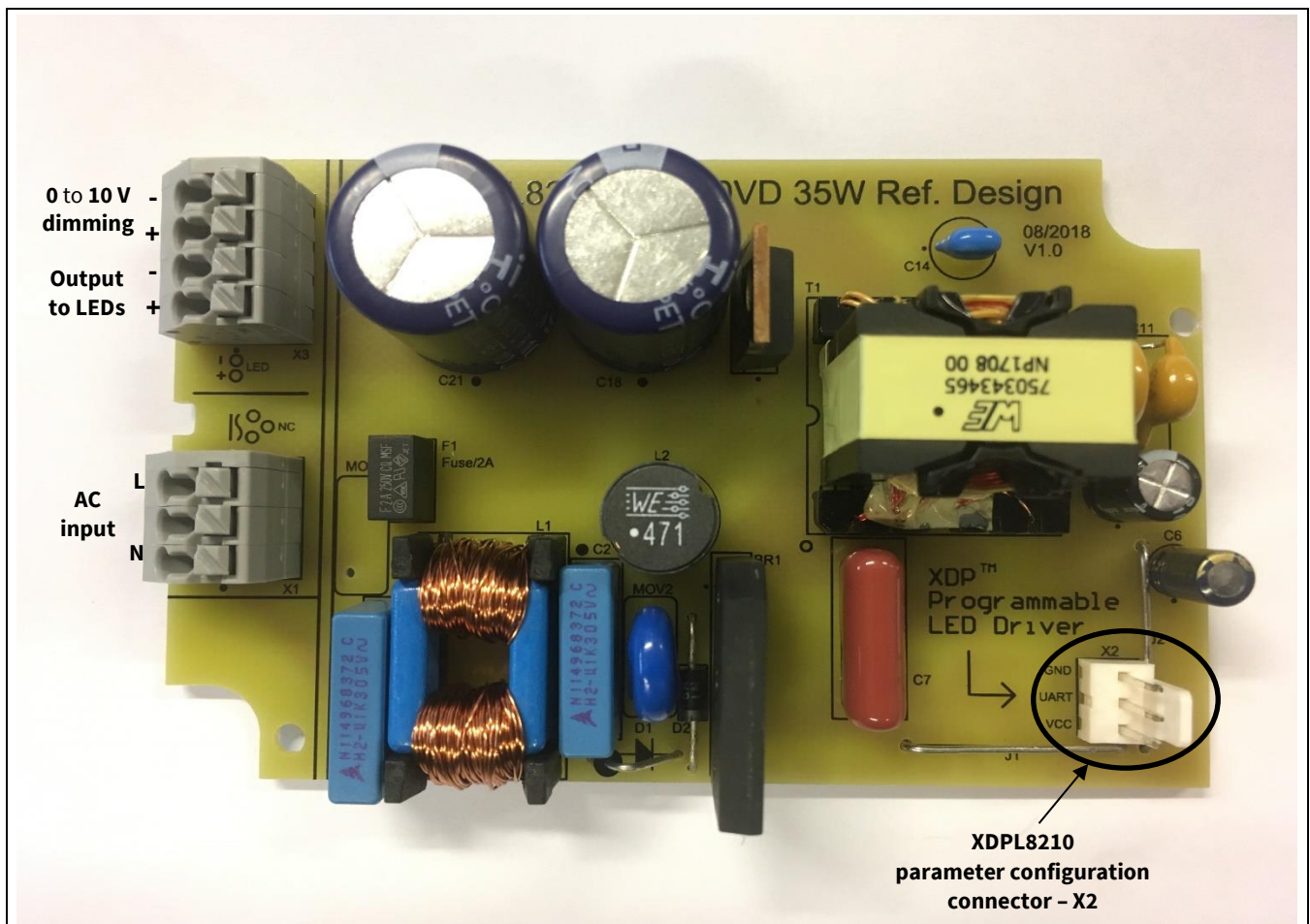

Figure 1 XDPL8210 CDM10VD 35 W reference design

Design features

2 Design features

- **Primary Side Regulated (PSR) Constant Current (CC) output**
- Supports **universal input with 90 V_{rms} to 305 V_{rms}**
- **HPF and low Total Harmonic Distortion (iTHD)**
- **High efficiency with QR mode with first valley switching (QRM1) operation at high output power**
- **High efficiency with frequency controlled Discontinuous Conduction Mode (DCM) operation at medium output power**
- **Dim-to-off operation with low standby power**
- Transformer-less **IEC60929-compliant isolated 0 to 10 V dimming using CDM10VD**
- **Maximum output power limit setting**
- **UL1310 Class 2 output for 54 V LED driver design with adaptive output Over Voltage Protection (OVP)**
- **Input OVP and Under Voltage (brown-in/brown-out) Protection (UVP)**
- **Output short protection**
- **Configurable dimming parameters**, e.g. dimming curve (linear/quadratic), minimum current, dim-to-off option (enabled/disabled)
- **Configurable protection parameters**, e.g. protection thresholds and reaction (auto-restart/latch)
- **Low Bill of Materials (BOM)**

Note: CDM10VD is a device that transmits analog voltage-based signals from a 0 to 10 V dimmer or potentiometer to the dimming or PWM input of a lighting controller IC in the form of a 5 mA current-based PWM signal to drive an external isolated optocoupler. It replaces many components in a traditional solution and reduces BOM and PCB space significantly. For more details about CDM10VD, please visit the Infineon website:

<https://www.infineon.com/cms/en/product/power/lighting-ics/dimming-interface-ics/cdm10vd/>

Board specifications

3 Board specifications

Figure 2 shows the operating window of the reference design.

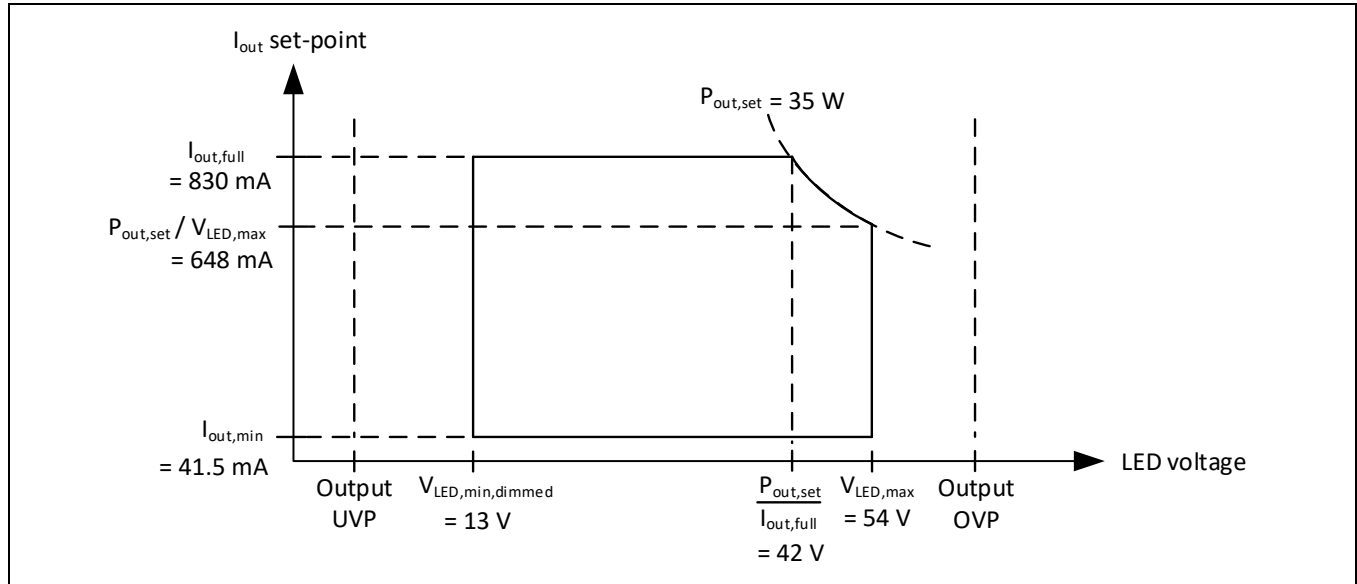

Figure 2 Operating window

Table 1 and Table 2 respectively list the electrical specifications and system protection parameter values of the reference design.

Table 1 Electrical specifications

Specification	Symbol	Value	Unit
Normal operational AC input voltage	V AC	90 ~ 305	V _{rms}
Normal operational AC input frequency	F _{line}	47 ~ 63	Hz
Steady-state maximum output current set-point	I _{out, full}	830	mA
Steady-state maximum output power limit set-point	P _{out, set}	35	W
Steady-state maximum output LED load voltage	V _{LED, max}	54	V
Steady-state minimum output LED load voltage (non-dimmed)	V _{LED, min, non-dimmed}	18	V
Steady-state minimum output LED load voltage (dimmed)	V _{LED, min, dimmed}	13	V
Total line, load regulation (non-dimmed)	ΔI _{out}	±2	%
Dimming input	V _{DIMMER}	0 ~ 10	V
Minimum output current set-point	I _{out, min}	41.5	mA
Output current dimming curve shape	C _{DIM}	Linear	-
Standby power (V AC = 120 V _{rms} to 277 V _{rms} ; V _{DIMMER} = 0 V)	P _{standby}	180	mW
Dimming input sensing interval during dim-to-off	t _{dim, sense, off}	0.4	s

XDPL8210 CDM10VD 35 W reference design with IPN80R900P7

For LED driver with isolated 0 to 10 V dimming and dim-to-off operation



Board specifications

Specification	Symbol	Value	Unit
Efficiency (V AC = 120 V _{rms} to 277 V _{rms} ; V _{LED} = 42 V to 54 V; non-dimming)	η	More than 89	%
Power Factor 1 (V AC = 230 V _{rms} ; F _{line} = 50 Hz; V _{LED} = 18 V to 54 V; non-dimming)	PF ₁	More than 0.95	-
Power Factor 2 (V AC = 120 V _{rms} to 277 V _{rms} ; F _{line} = 60 Hz; V _{LED} = 30 V to 54 V; non-	PF ₂	More than 0.92	-
Total Harmonic Distortion 1 (V AC = 230 V _{rms} ; F _{line} = 50 Hz; V _{LED} = 18 V to 54 V; non-dimming)	iTHD ₁	Less than 10	%
Total Harmonic Distortion 2 (V AC = 120 V _{rms} to 277 V _{rms} ; F _{line} = 60 Hz; V _{LED} = 18 V to 54 V; non-	iTHD ₂	Less than 15	%

Board specifications

Table 2 System protection parameter values

System protection parameter	Symbol	Value	Unit
Input OVP level ¹	V_{inOV}	352	V_{rms}
Maximum input voltage level for start-up ¹	$V_{in,start,max}$	326	V_{rms}
Brown-in/minimum input voltage level for start-up ¹	$V_{in,start,min}$	80	V_{rms}
Brown-out/input UVP level ¹	V_{inUV}	63	V_{rms}
Output OVP level ¹	V_{outOV}	56.9	V
Output OVP level during auto-restart ¹	$V_{outOV,red}$	51.3	V
Regulated mode output UVP level	V_{outUV}	6	V
Regulated mode output UVP blanking time ¹	$t_{VoutUV,blank}$	40	ms
Regulated mode maximum peak output current protection level ¹	$I_{out,max,peak}$	2.1	A
Regulated mode maximum peak output current protection blanking time ¹	$t_{Iout,max,peak,blank}$	1.0	ms
Auto-restart speed for regulated mode maximum peak output current protection ¹	Speed _{OCP,Iout}	Fast	
V_{CC} OVP level	$V_{VCC,max}$	24	V
Regulated mode Current Sense (CS) pin voltage level 1 for MOSFET maximum current cycle-by-cycle limit at lowest operational input voltage ¹	V_{OCP1}	0.50	V
IC over-temperature protection level ²	$T_{critical}$	119	°C
Maximum IC temperature for start-up	$T_{start,max}$	115	°C
Input OVP reaction	Reaction _{OVP,Vin}	Auto-restart	–
Input UVP reaction	Reaction _{UVP,Vin}	Auto-restart	–
Output OVP reaction ¹	Reaction _{OVP,Vout}	Auto-restart	–
Start-up output UVP reaction	Reaction _{UVP,Vout,start}	Auto-restart	–
Regulated mode output UVP reaction	Reaction _{UVP,Vout}	Auto-restart	–
Regulated mode maximum peak output current protection reaction	Reaction _{Iout,max,peak}	Auto-restart	–
V_{CC} OVP reaction	Reaction _{VCC,OVP}	Auto-restart	–
IC over-temperature protection reaction	Reaction _{TP}	Auto-restart	–
Fast auto-restart time	$t_{auto,restart,fast}$	0.4	s
Auto-restart time ¹	$t_{auto,restart}$	1.6	s

Note: The input, output voltage sensing for these protections are estimated from ZCD pin switching signals. To improve the input voltage estimation accuracy, CS pin switching signal is also sensed.

Note: Regulated mode is a controller operating state, which is entered after the start-up phase, to regulate the output.

¹ Configurable

² Configurable up to 143°C (lifetime is not guaranteed when IC operating junction temperature is above 125°C)

4 Schematic and PCB layout

Figure 3 shows the schematic of this reference design.

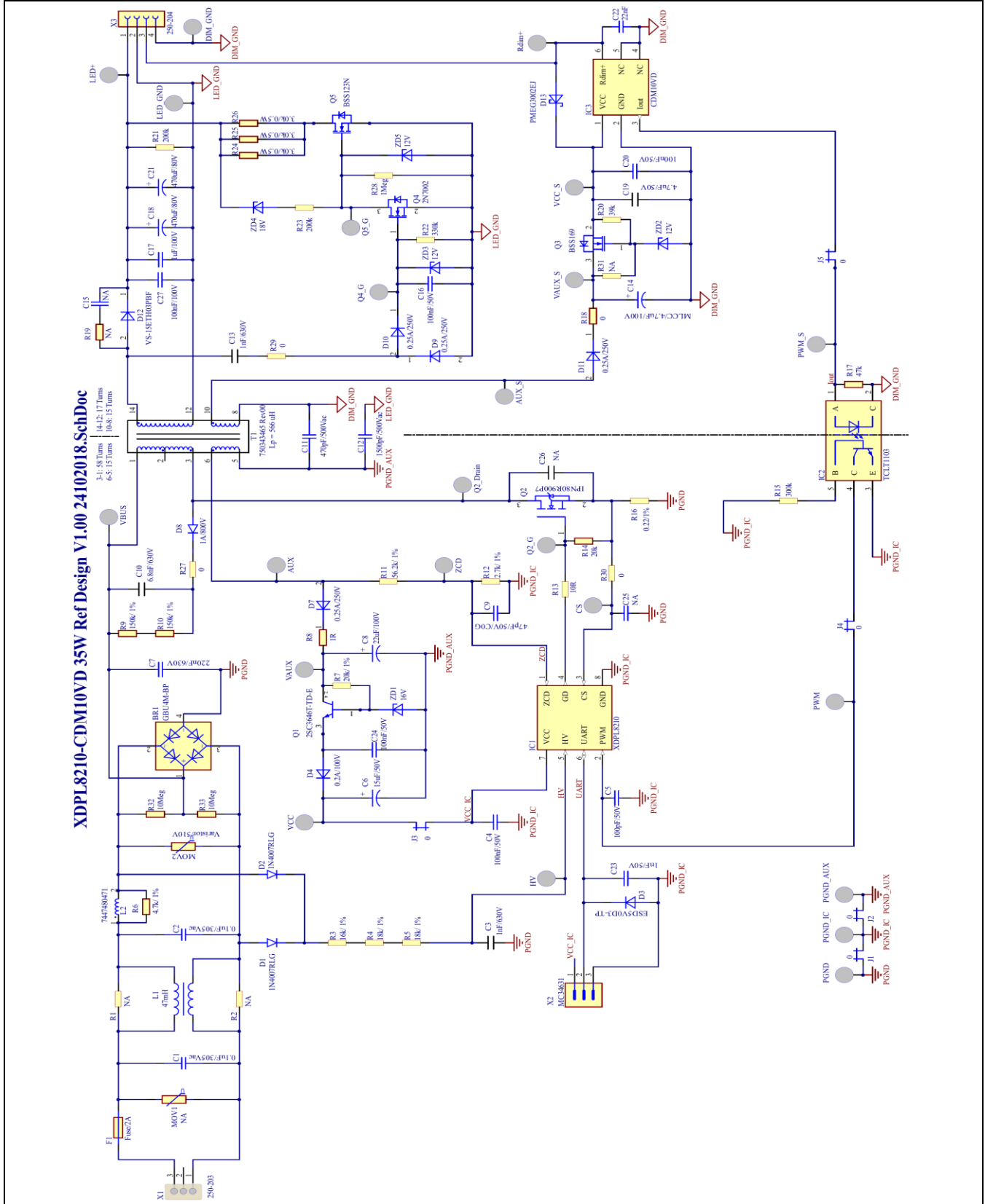

Figure 3 XDPL8210 CDM10VD 35 W reference design main board schematic

XDPL8210 CDM10VD 35 W reference design with IPN80R900P7

For LED driver with isolated 0 to 10 V dimming and dim-to-off operation



Schematic and PCB layout

The XDPL8210 CDM10VD 35 W reference design has a single-layer PCB layout design. **Figure 4** and **Figure 5** respectively show the PCB top layout (with dimensions) and bottom layout.

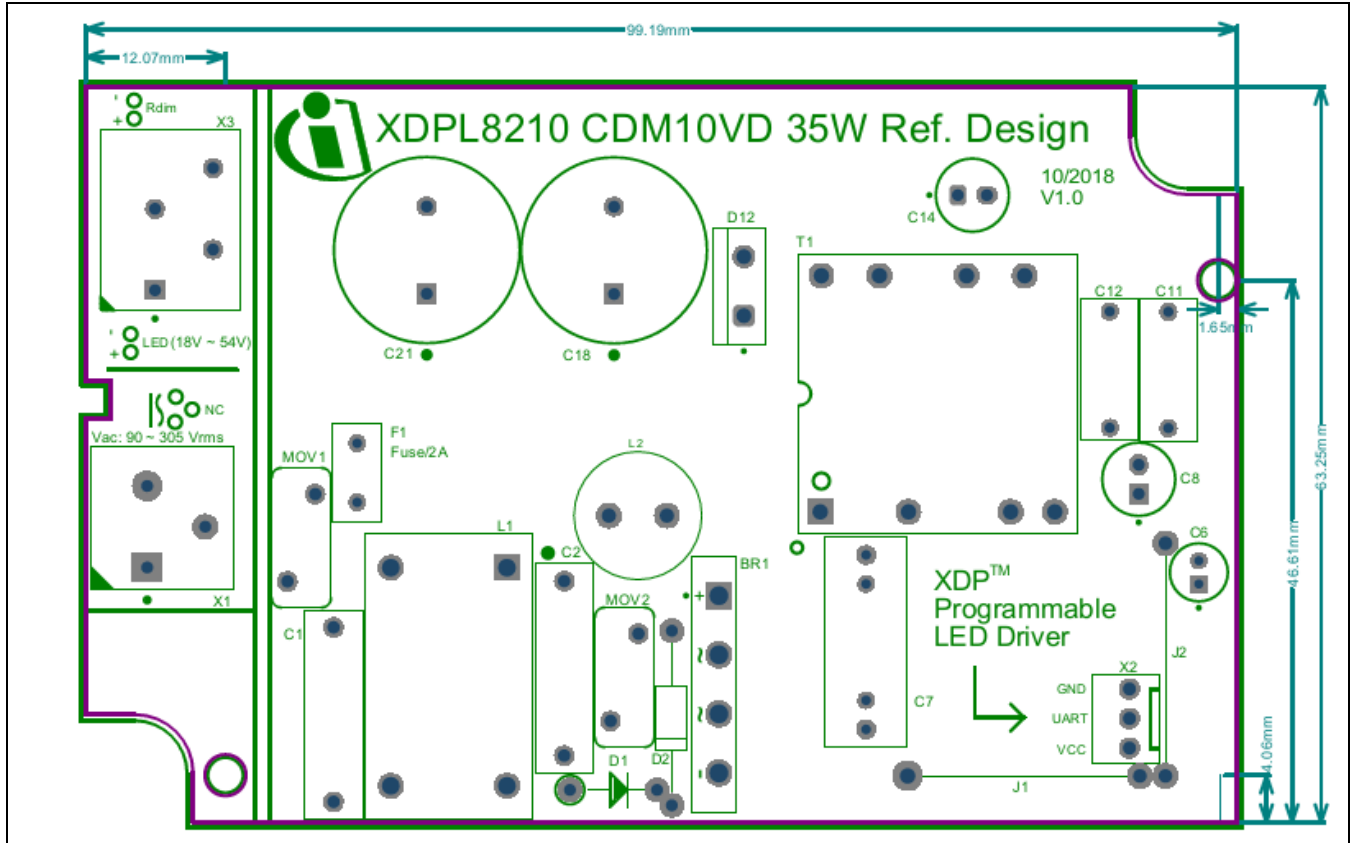

Figure 4 PCB top layout with dimensions

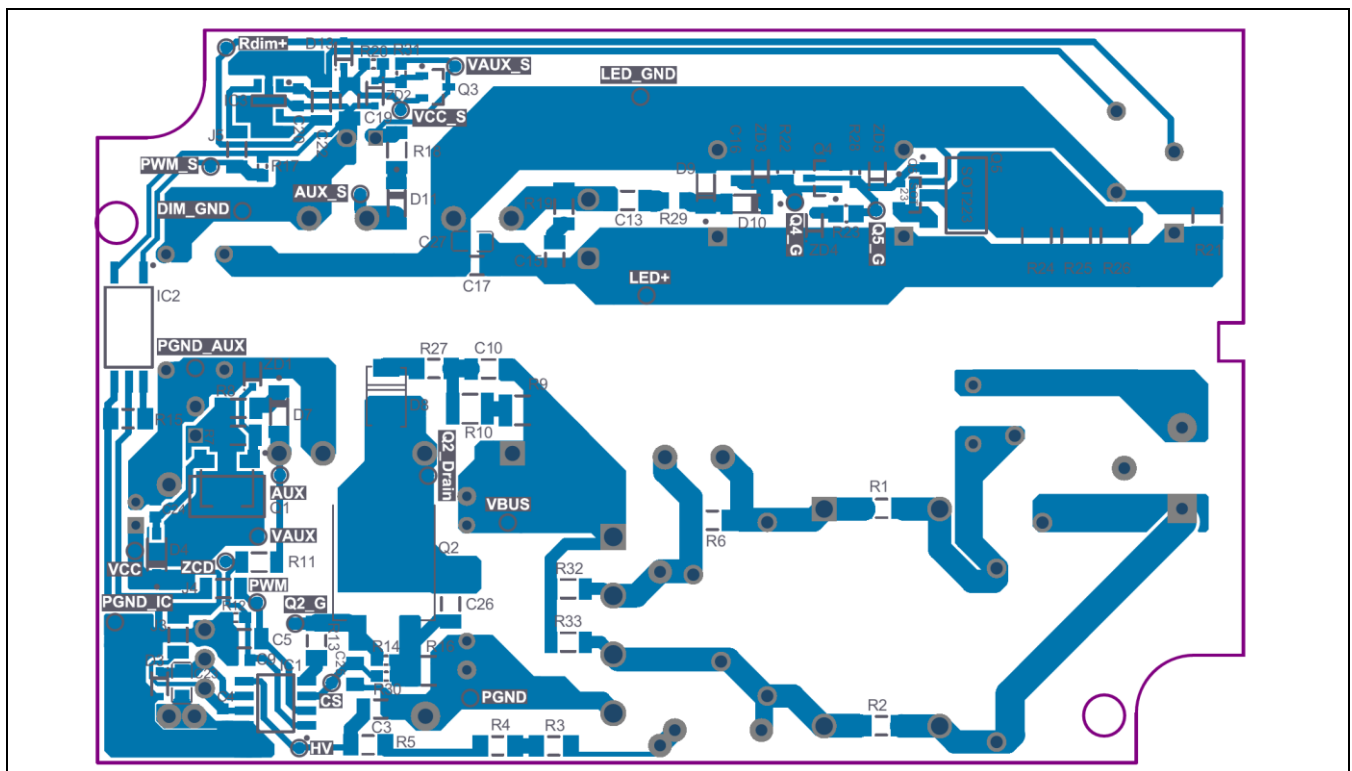

Figure 5 PCB bottom layout

Performance

5 Performance

The results shown in this section are based on the evaluation of a single reference board.

5.1 Non-dimming

The measurement results under non-dimming condition are presented in this section.

5.1.1 Line and load regulation

The total line and load regulation of the output current under non-dimming condition is well within ± 2 percent, as shown in **Figure 6**.

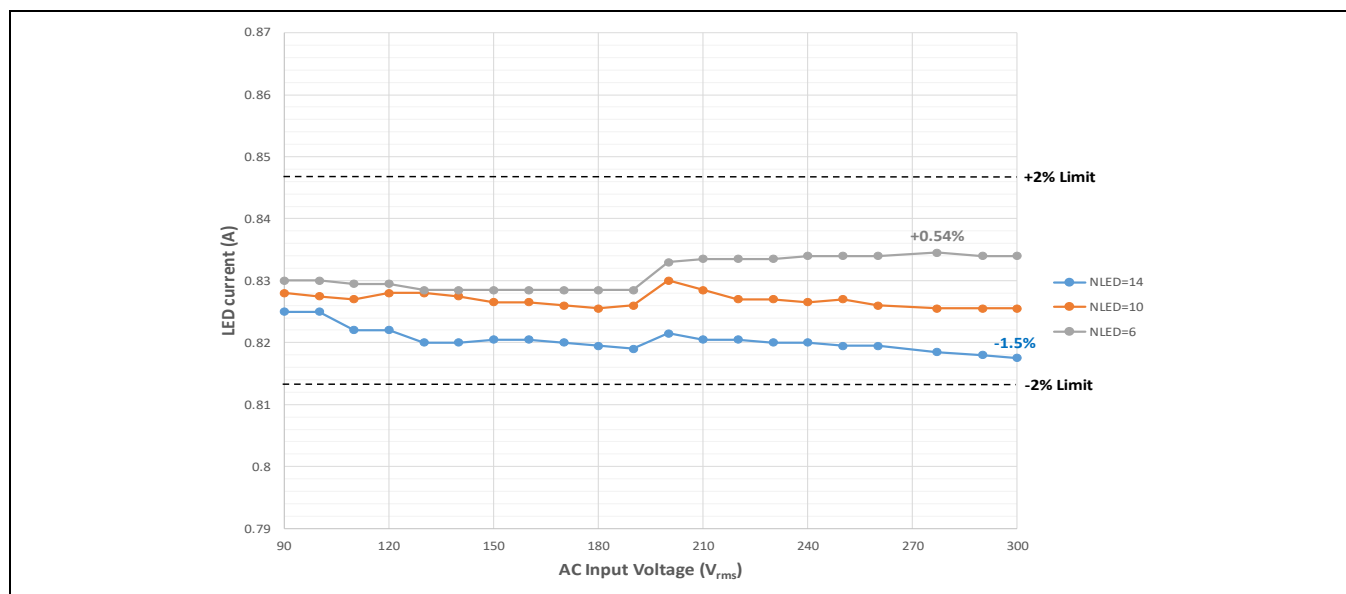

Figure 6 Line and load regulation test result (non-dimmed output current)

The total line and load regulation of the output power limit under non-dimming condition is within ± 1 percent approximately, as shown in **Figure 7**.

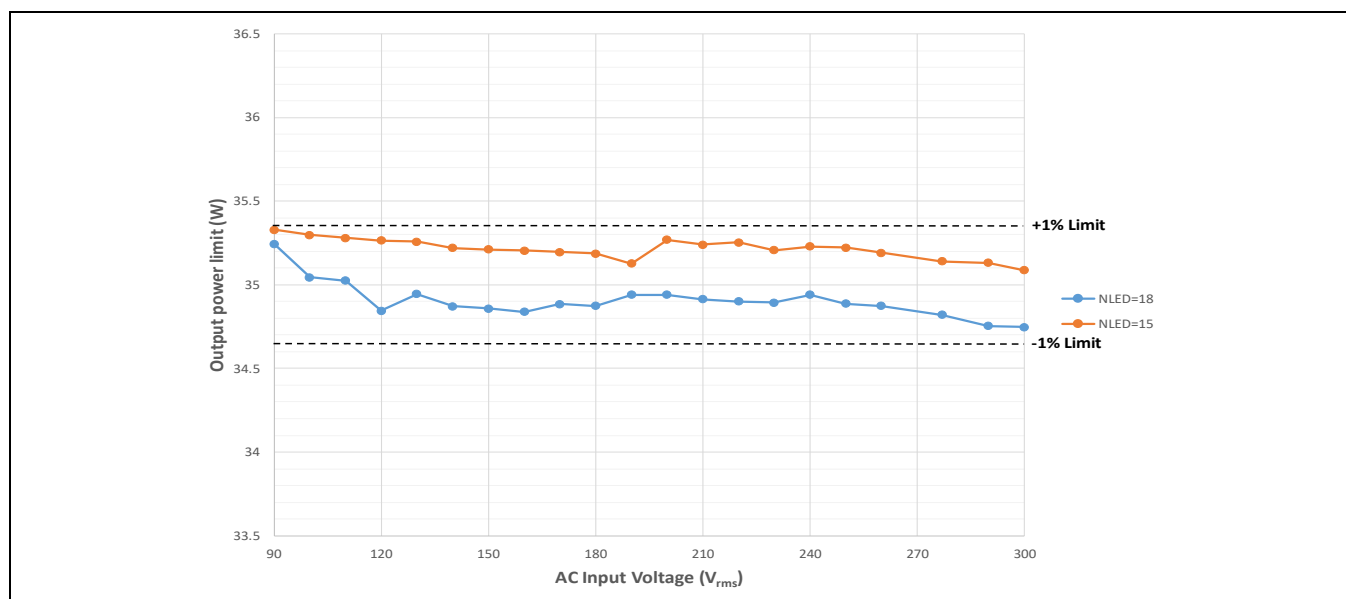

Figure 7 Line and load regulation test result (output power limit)

Performance

5.1.2 System efficiency

The system efficiency measurements under non-dimming condition are shown in **Figure 8**.

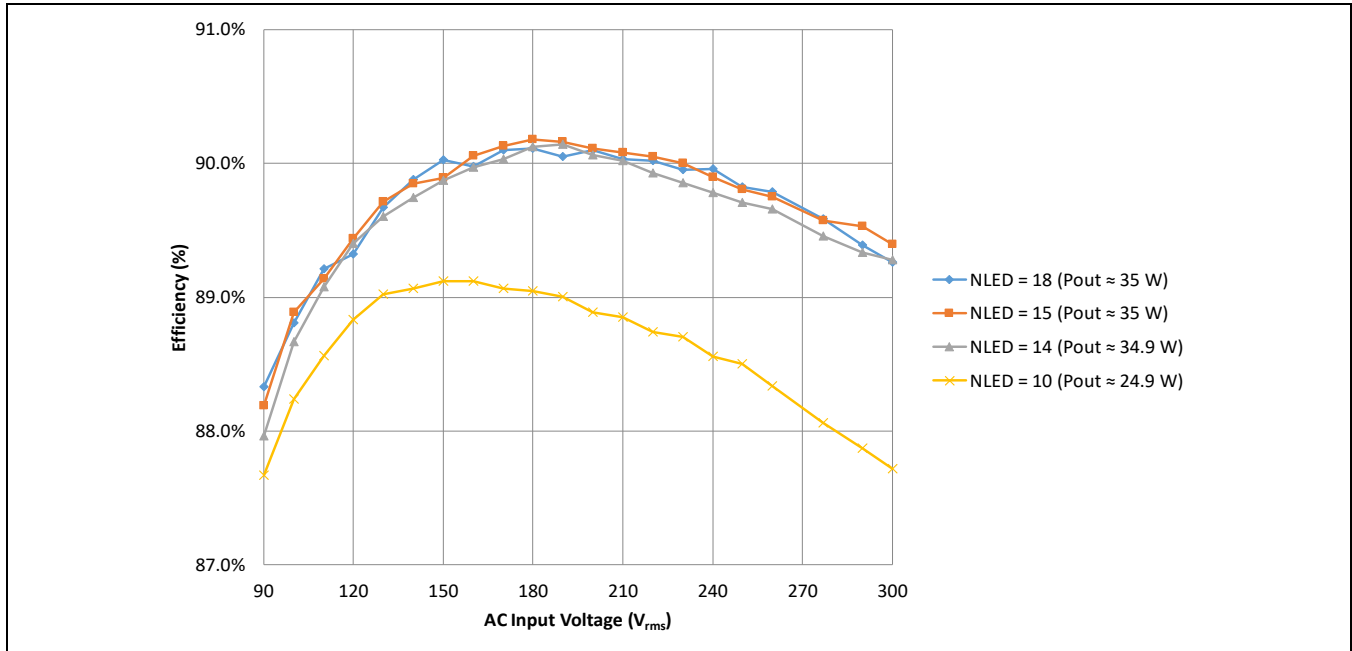

Figure 8 System efficiency test result

5.1.3 Power Factor (PF) and Total Harmonic Distortion (iTHD)

Across a wide LED load range (N_{LED} = 6 to 18) under non-dimming condition, the PF is above 0.94 with V_{AC} = 230 V_{rms} (F_{line} = 50 Hz), as shown in **Figure 9**.

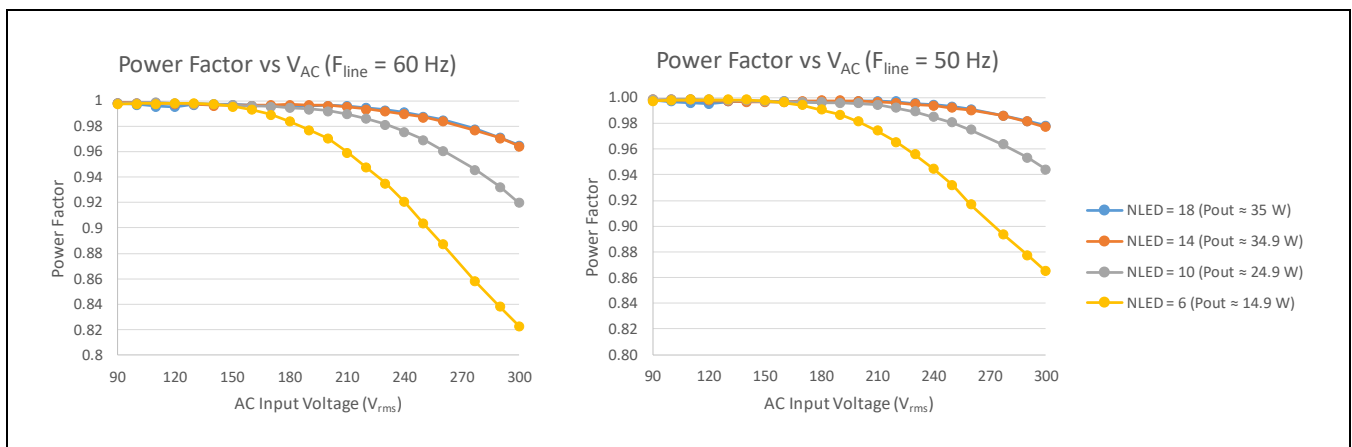

Figure 9 PF test result (non-dimming condition)

Across a wide LED load range (N_{LED} = 6 to 18) under non-dimming condition, the iTHD measurements shown in **Figure 10** are:

- Less than 10 percent with V_{AC} = 230 V_{rms} (F_{line} = 50 Hz)
- Less than 15 percent with V_{AC} = 120 V_{rms} to 277 V_{rms} (F_{line} = 60 Hz)

Performance

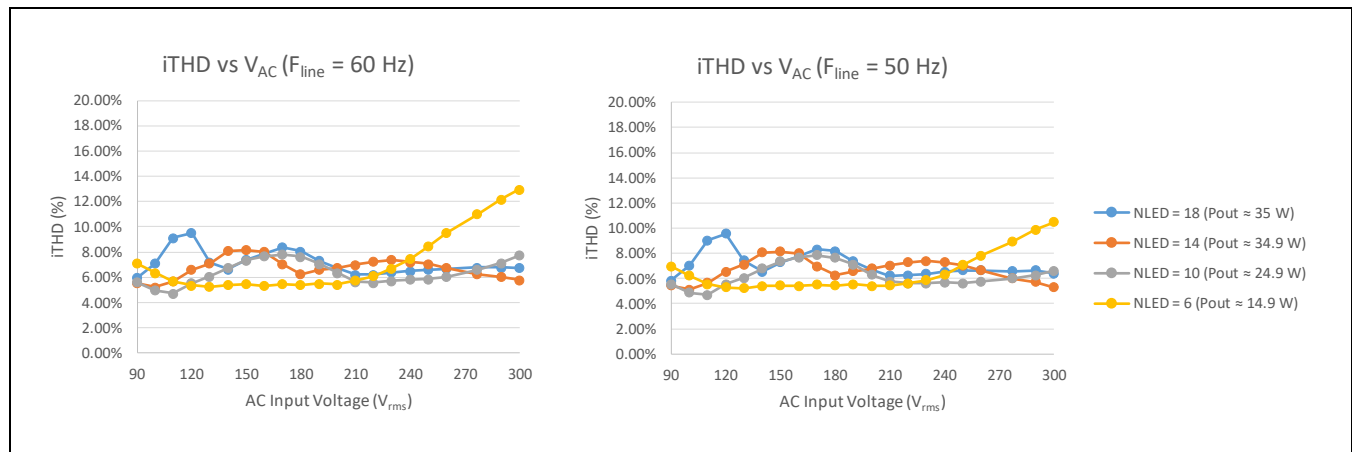

Figure 10 iTHD test result

5.1.4 Current harmonics

Figure 11 to Figure 13 show the current harmonics measurement compared to the IEC61000-3-2 Class C limit.

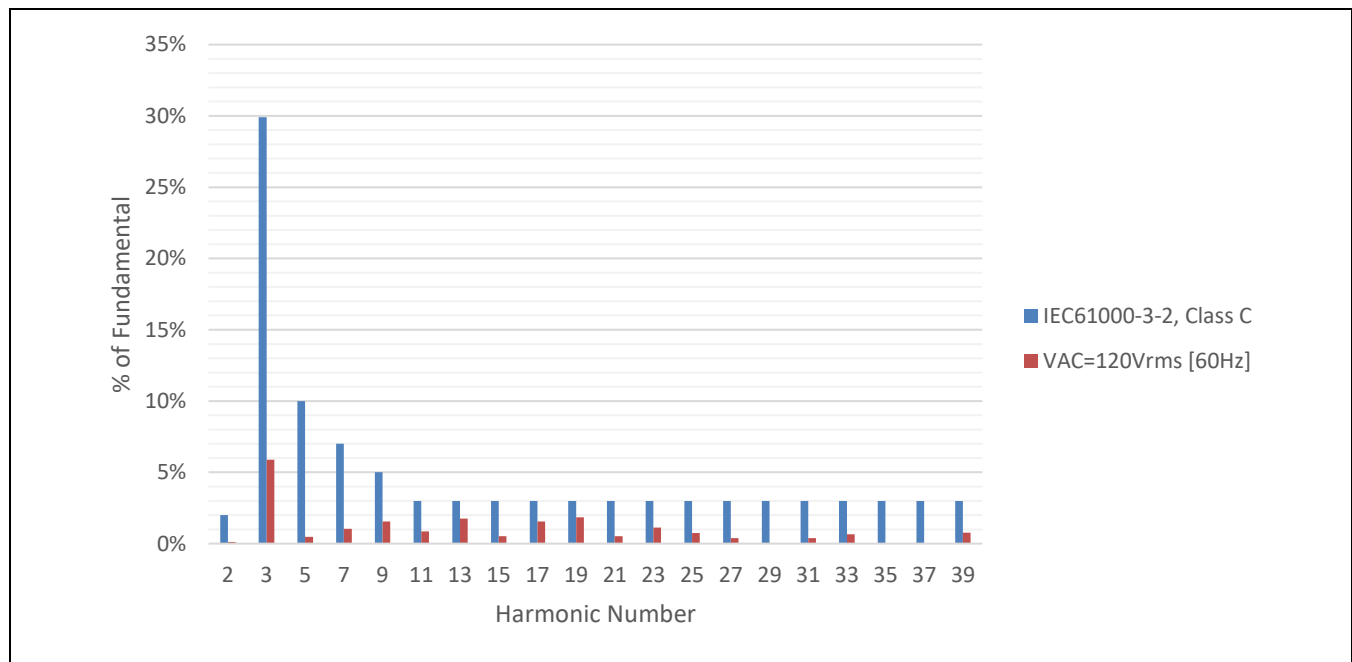

Figure 11 Current harmonics at V_{AC} = 120 V_{rms}, F_{line} = 60 Hz, N_{LED} = 15 and P_{out} = 35 W

Performance

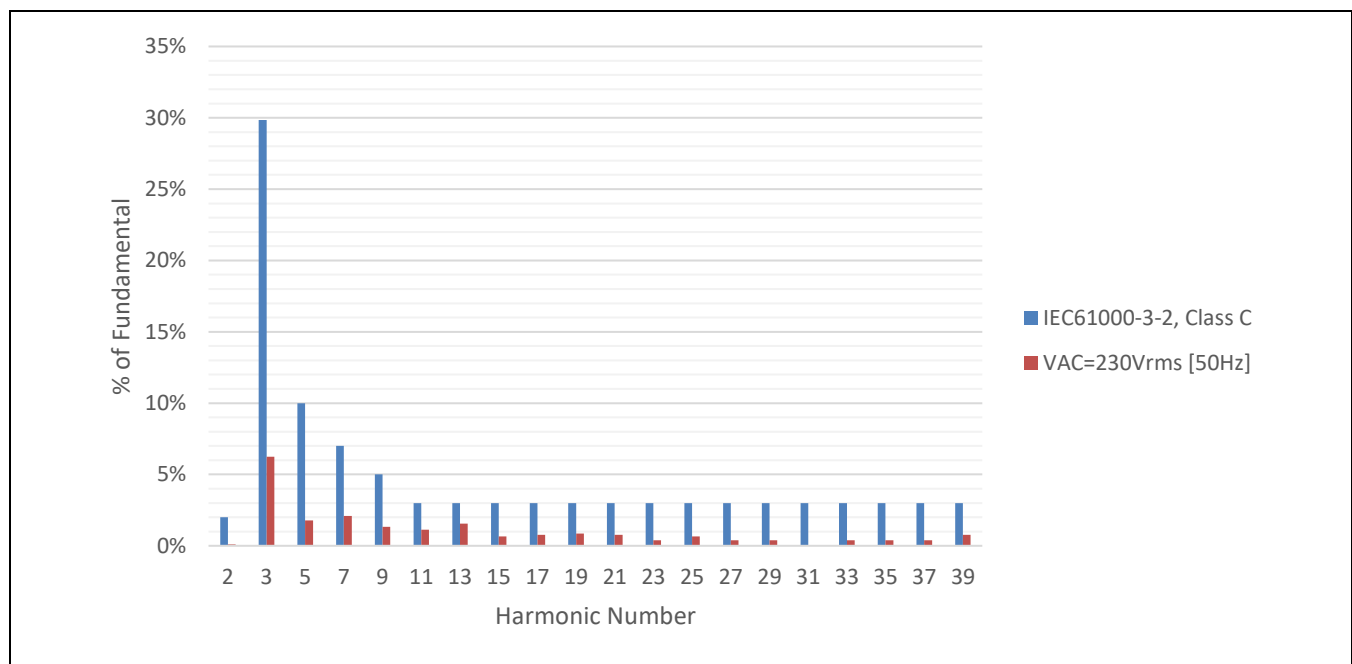

Figure 12 Current harmonics at V AC = 230 V_{rms}, F_{line} = 50 Hz, N_{LED} = 15 and P_{out} = 35 W

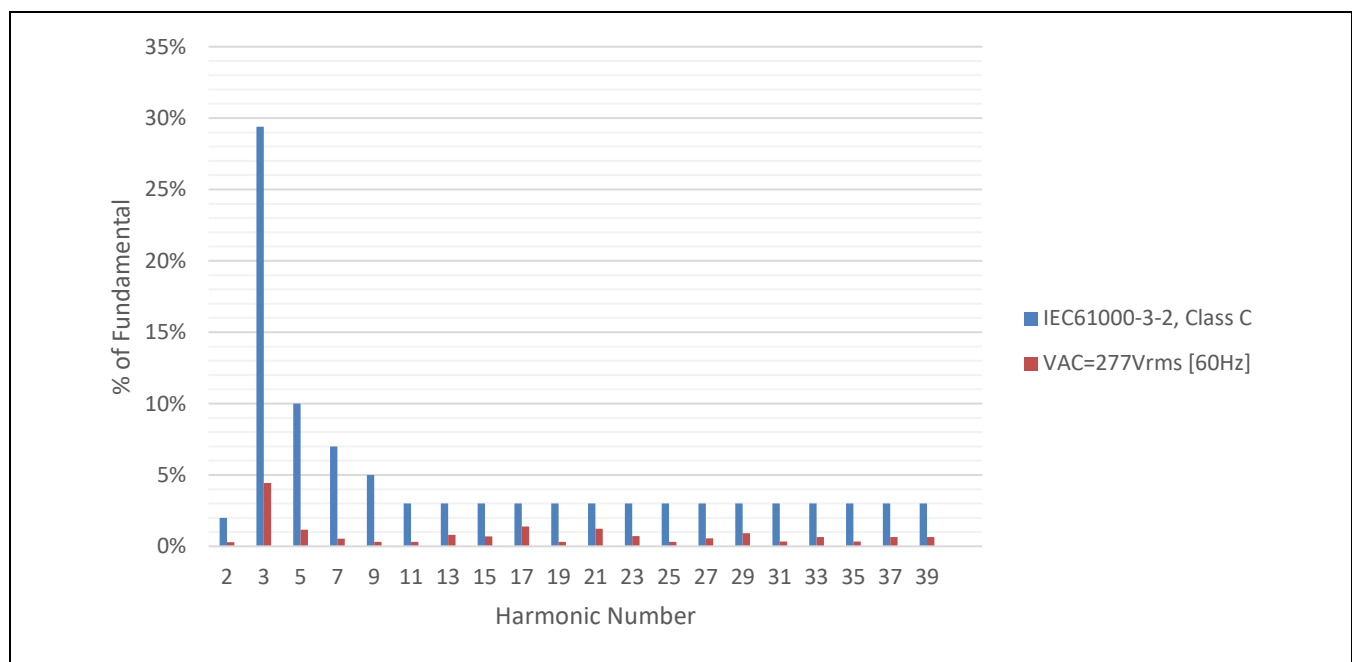

Figure 13 Current harmonics at V AC = 277 V_{rms}, F_{line} = 60 Hz, N_{LED} = 15 and P_{out} = 35 W

5.1.5 Thermal test

The open-frame thermal test was done on the reference design using an infrared thermography camera (FLIR-T62101) at an ambient temperature of approximately 25°C. The temperature measurements of the following main components (see [Table 3](#)) were taken after 1 hour running.

Performance

Table 3 Main components for temperature measurement

PCB bottom			PCB top		
Measuring point	Component	Description	Measuring point	Component	Description
sp1	IC1	Flyback controller (XDPL8210)	sp1	D12	Secondary main output diode
sp2	Q2	Flyback MOSFET (IPN800R900P7)	sp2	T1	Flyback transformer
sp3	Q3	CDM10VD V_{CC} regulator depletion MOSFET (BSS169)	sp3	PCB	PCB above Q2

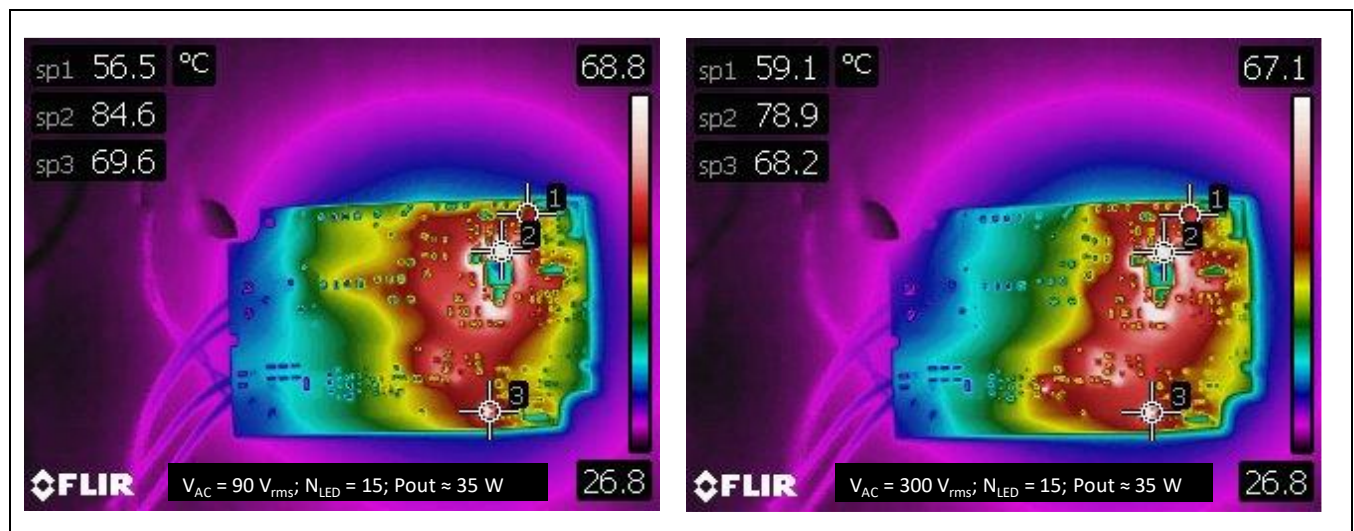

Figure 14 Infrared thermal image result of PCB bottom components

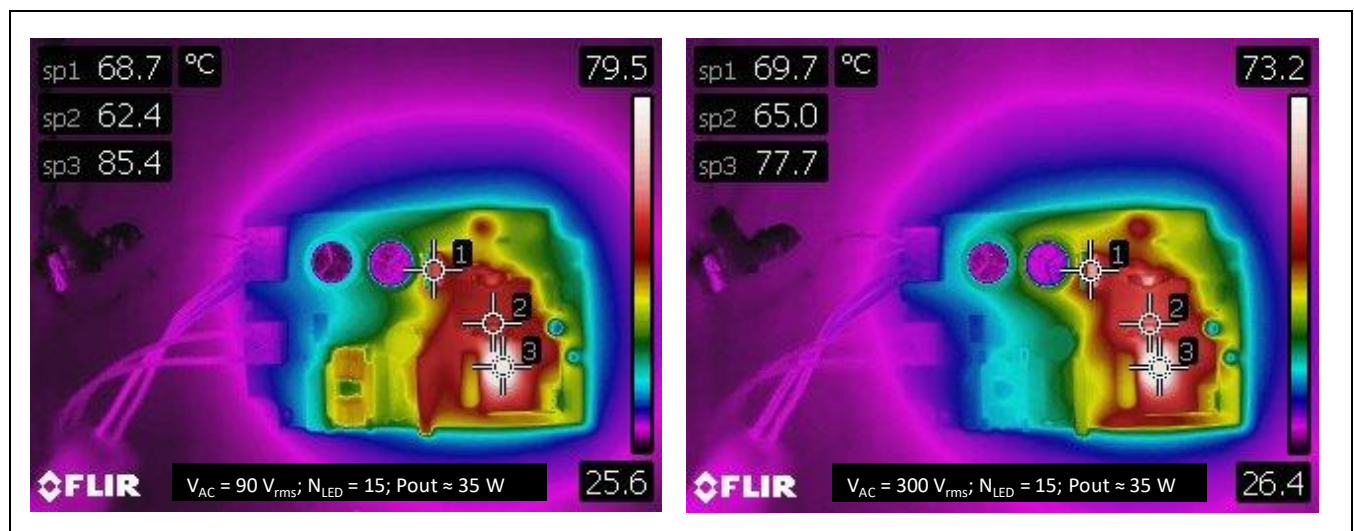

Figure 15 Infrared thermal image result of PCB top components

Performance

5.1.6 Conducted emissions (EN55015B)

The conducted emissions test was performed at full output power, and there is more than a 6 dB margin observed for both live and neutral measurements based on EN55015 standard Class B limits.

The measurement equipment used for this conducted emissions test was Schaffner NNB41 and SMR4503.

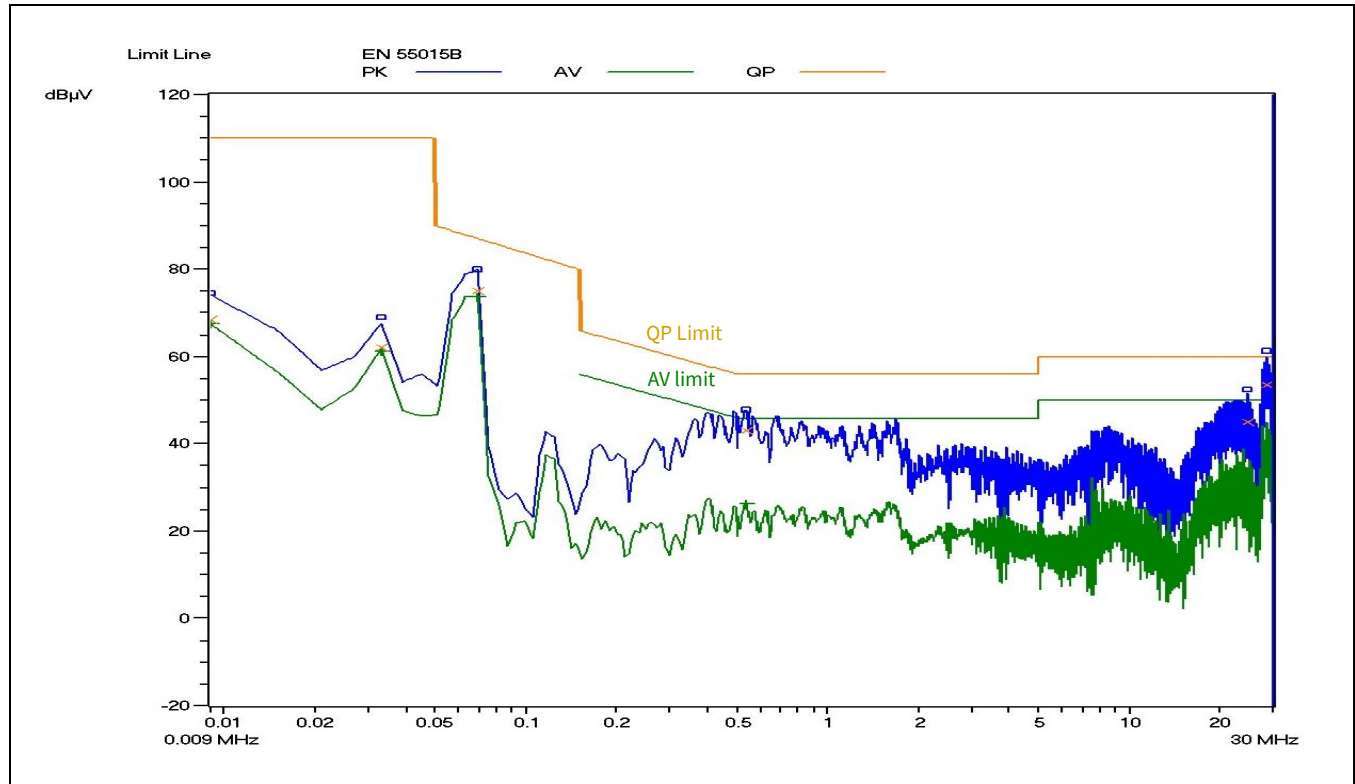

Figure 16 Conducted emissions (live) test result at $V_{AC} = 120 V_{rms}$, $F_{line} = 50 Hz$, $N_{LED} = 15$ and $P_{out} = 35 W$

Performance

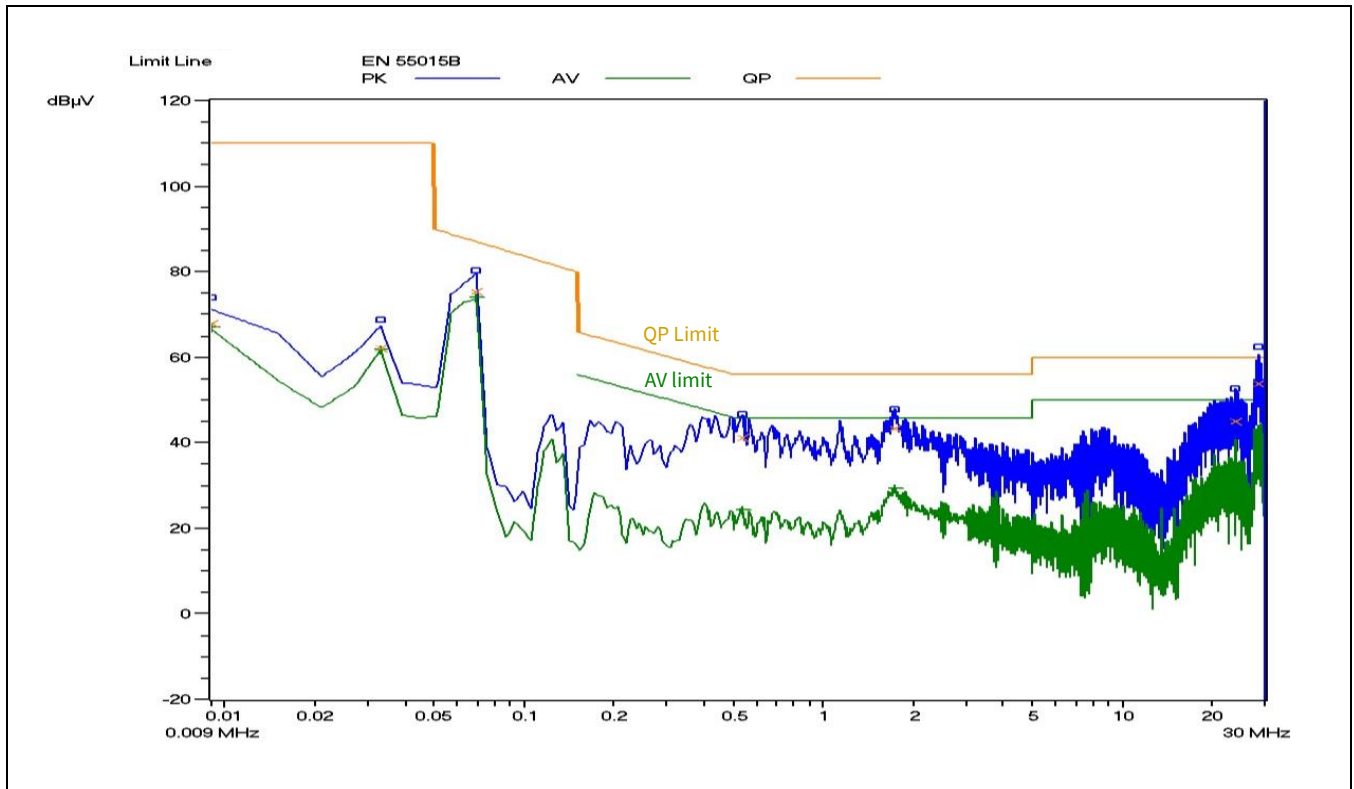

Figure 17 Conducted emissions (neutral) test result at $V_{AC} = 120 V_{rms}$, $F_{line} = 50 Hz$, $N_{LED} = 15$ and $P_{out} = 35 W$

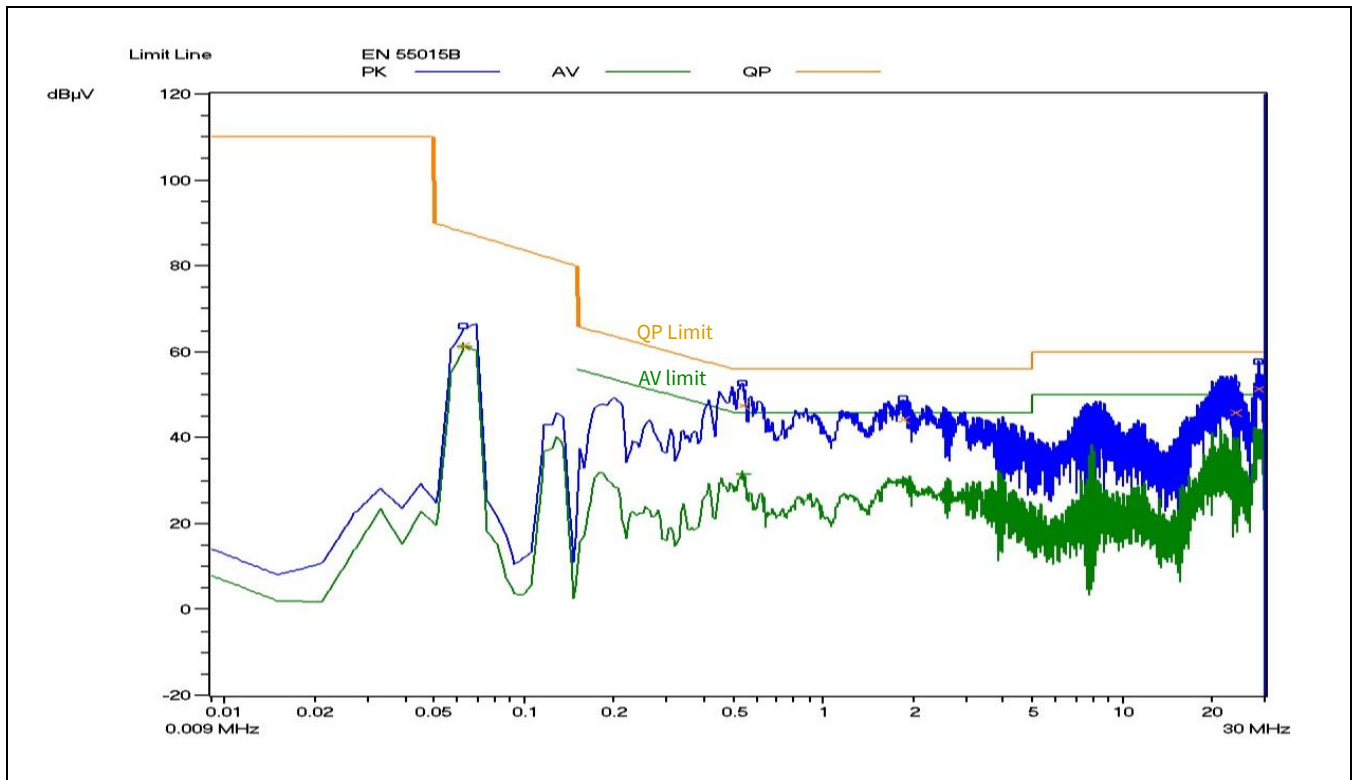

Figure 18 Conducted emissions (live) test result at $V_{AC} = 277 V_{rms}$, $F_{line} = 50 Hz$, $N_{LED} = 15$ and $P_{out} = 35 W$

Performance

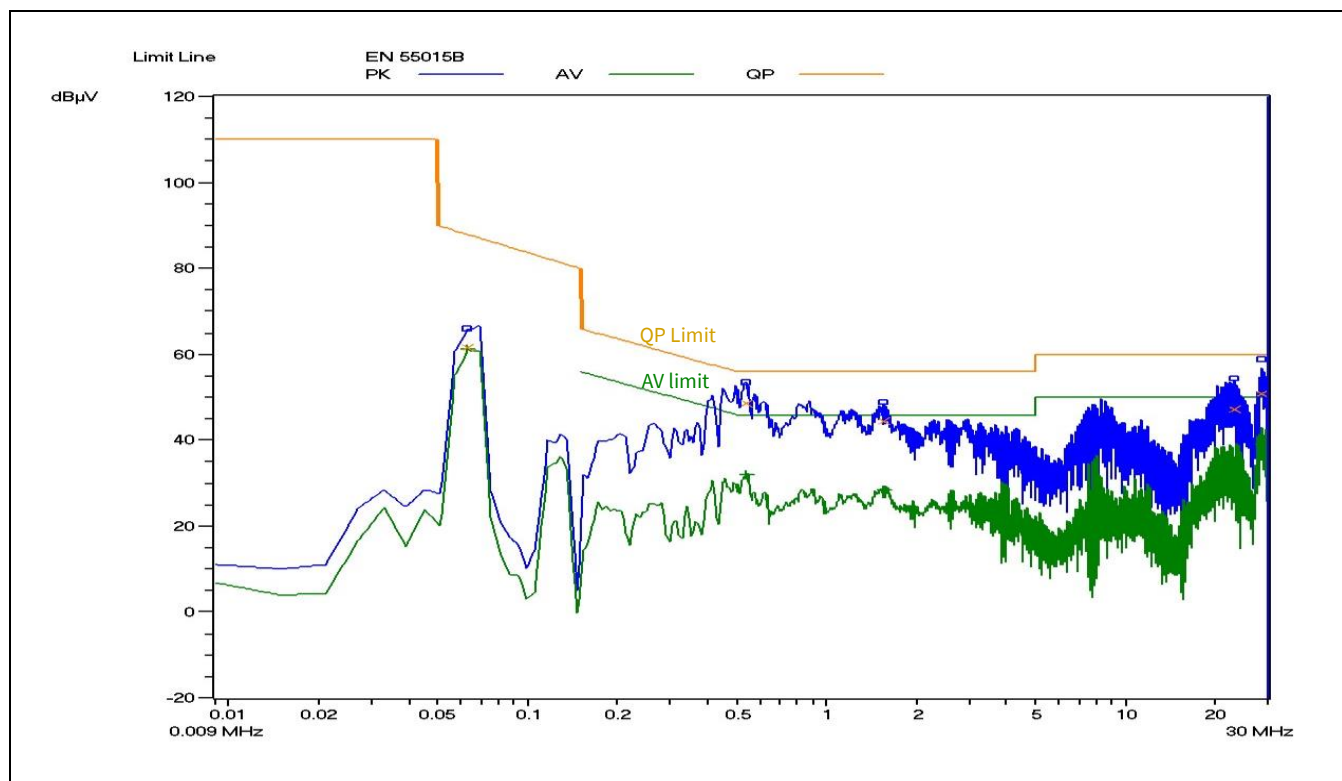

Figure 19 Conducted emissions (neutral) test result at $V_{AC} = 277 V_{rms}$, $F_{line} = 50 Hz$, $N_{LED} = 15$ and $P_{out} = 35 W$

5.2 Dimming

The measurement results under dimming condition are presented in this section.

5.2.1 Standby power

The standby power under dim-to-off condition ($V_{DIMMER} = 0 V$) is shown in **Figure 20**.

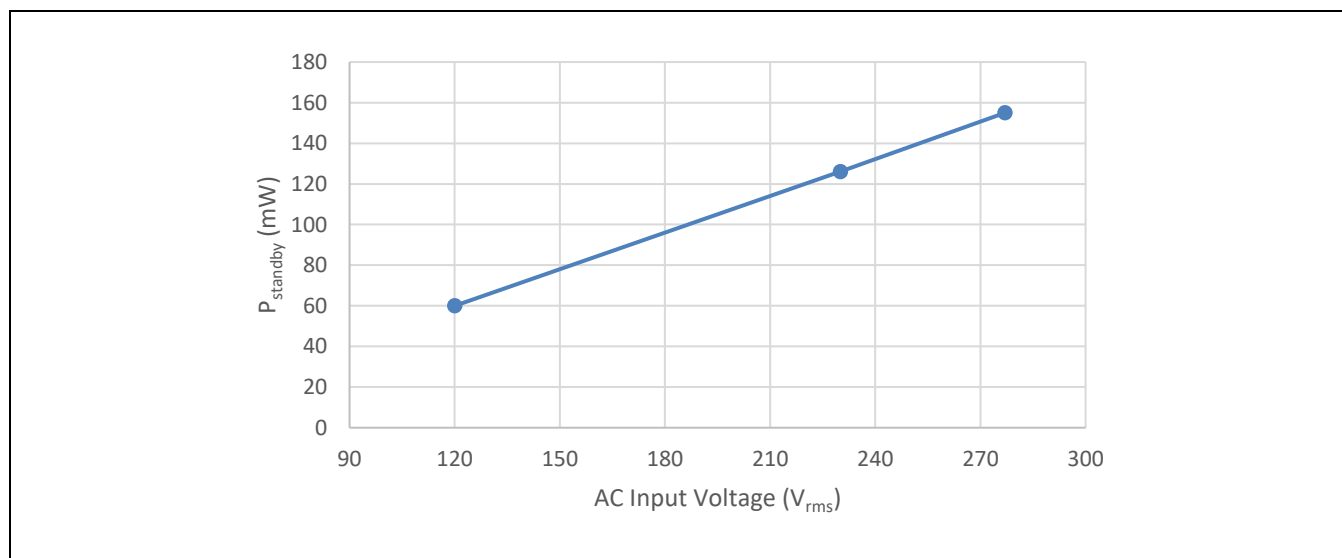

Figure 20 Standby power test result

Performance

5.2.2 LED current dimming curve

Figure 21 and Figure 22 respectively show the LED current dimming curve when the 0 to 10 V dimmer voltage is dimmed down and dimmed up.

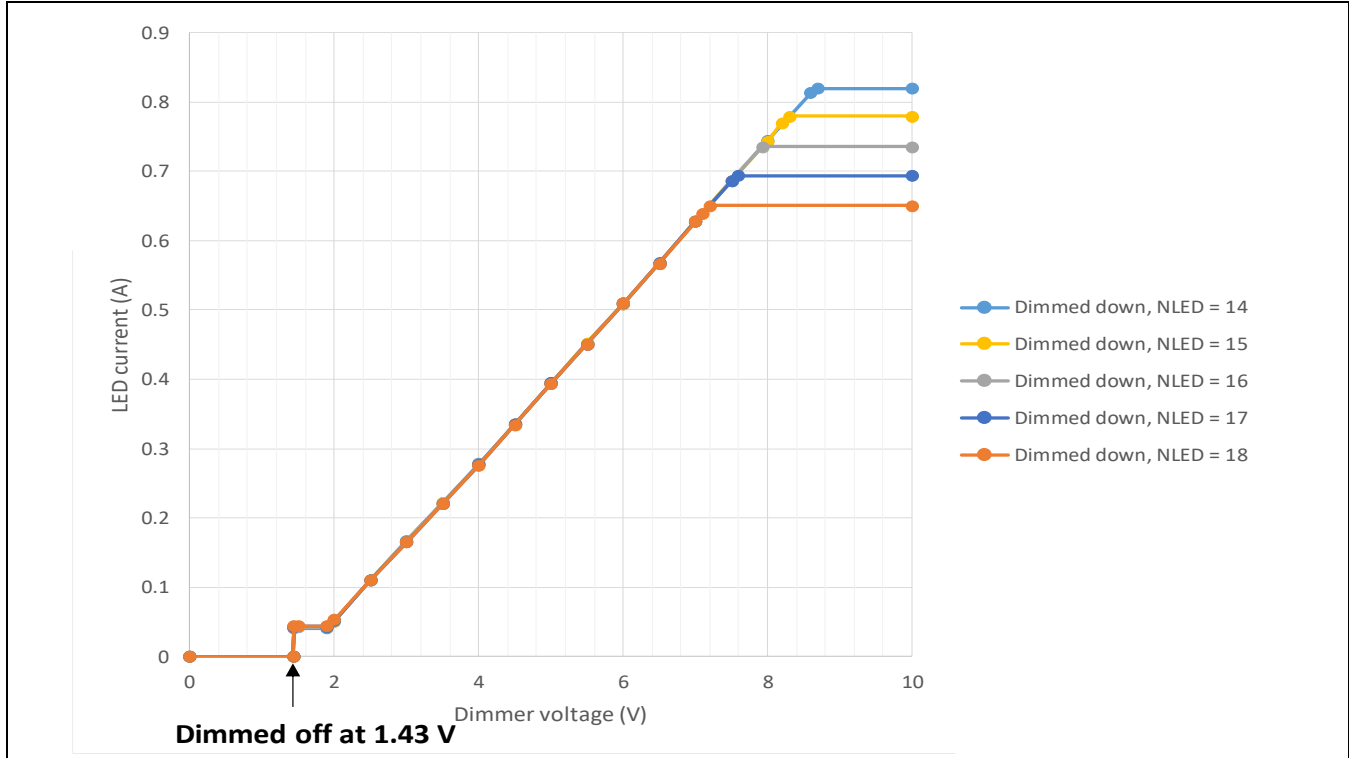

Figure 21 Output current dimmed down

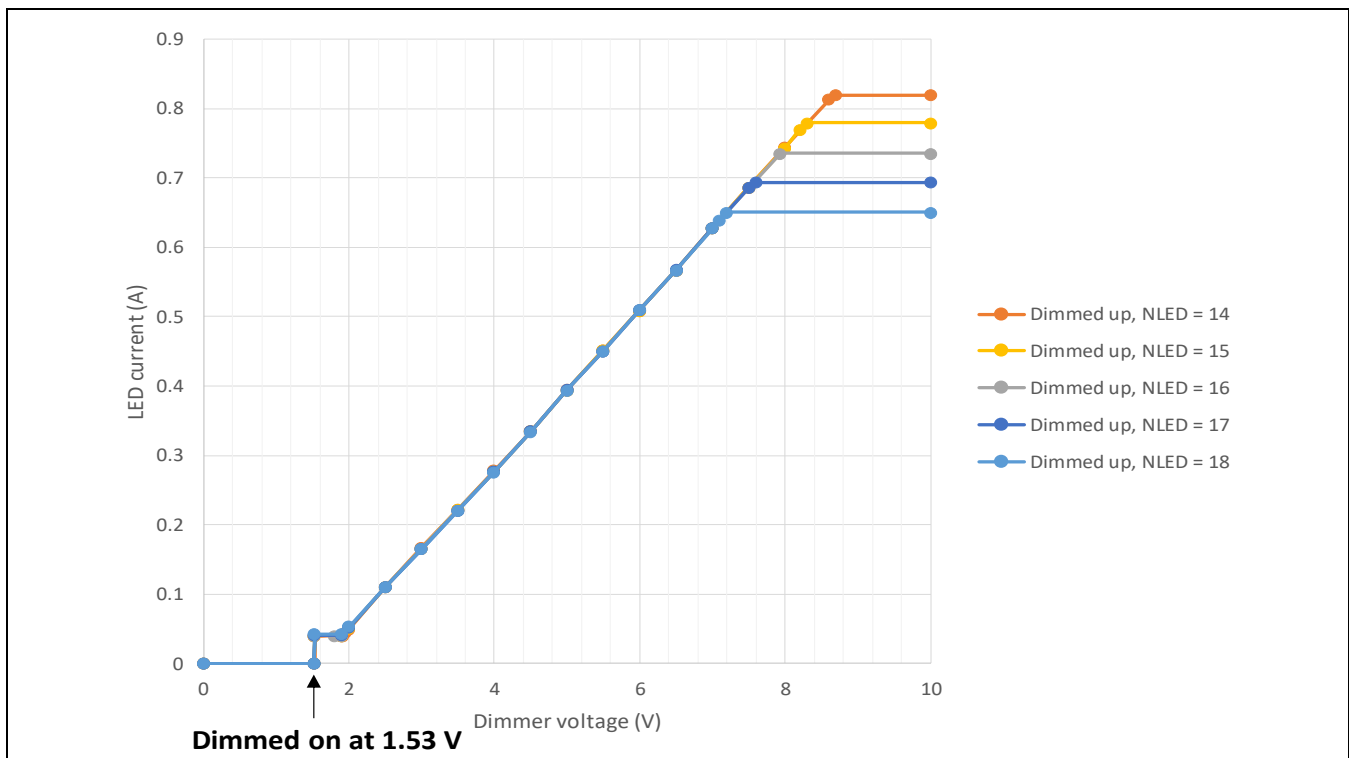

Figure 22 Output current dimmed up

Performance

Note: The dimming curve shape is linear by default and is configurable to quadratic (eye-adaptive). The dim-to-off is enabled by default and can be disabled by configuration.

Note: The minimum output current set-point by default is 41.5 mA (5 percent of full output current) and is configurable.

5.2.3 PF and iTHD

With input voltage $V_{AC} = 230 V_{rms}$, line frequency $F_{line} = 50 \text{ Hz}$ and LED load number $N_{LED} = 14$, the PF and iTHD are respectively above 0.9 and below 10 percent over a wide dimming range ($P_{out} = 33 \text{ percent to } 100 \text{ percent}$), as shown in **Figure 23**.

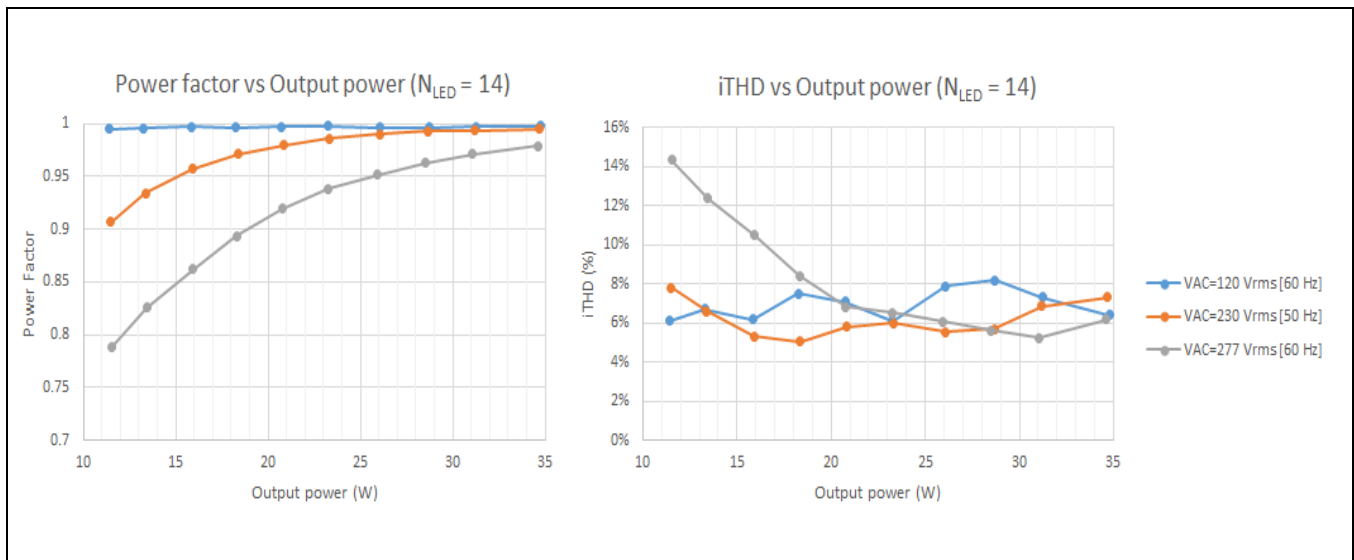

Figure 23 PF and iTHD (dimming condition)

5.3 Protections

The measurement results under protected condition are presented in this section.

5.3.1 Input UVP and maximum power limitation during brown-out

To better protect the primary components e.g. Flyback MOSFET from overheating and magnetics from saturation, XDPL8210 features not only an input UVP (via ZCD and CS pin signal sensing) with configurable threshold for output on/off, but also brown-out maximum power reduction, as shown in **Figure 24**.

Performance

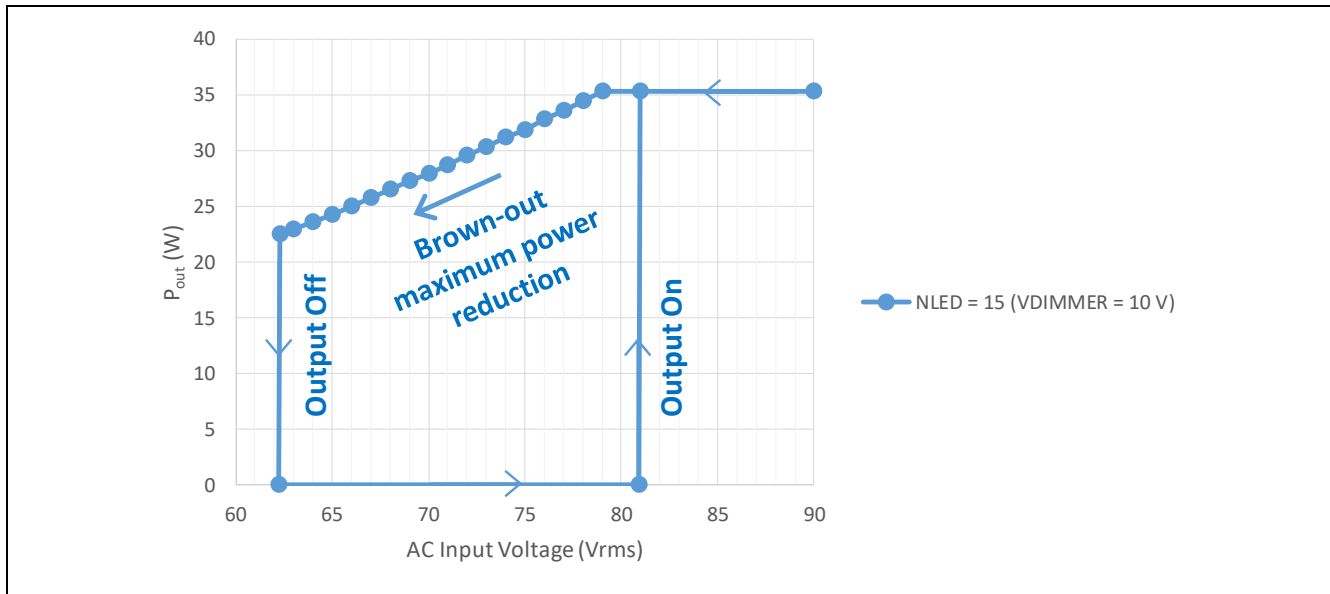

Figure 24 Input UVP and brown-out maximum power reduction

5.3.2 Input OVP

Apart from input UVP, XDPL8210 also features input OVP with configurable threshold for output on/off, as shown in **Figure 25**.

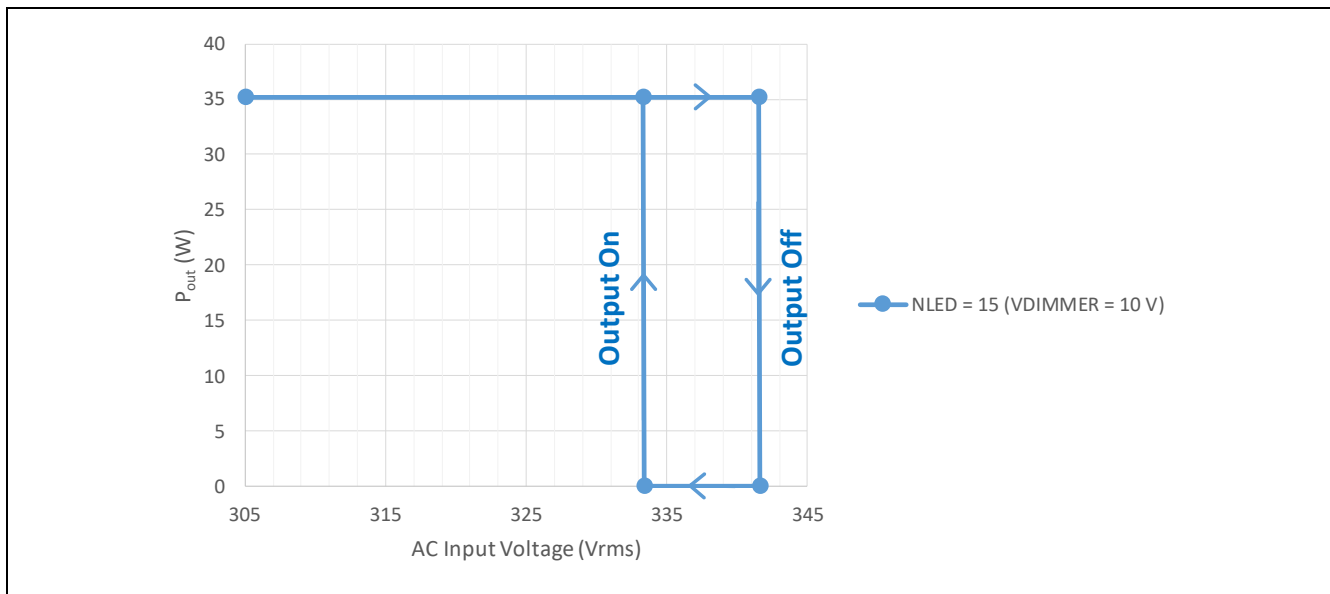

Figure 25 Input UVP and brown-out maximum power reduction

5.3.3 Adaptive output OVP

To meet UL1310 (standard for Class 2 power units) for a 54 V rated LED driver with primary-side output current regulation, XDPL8210 features an output OVP with adaptive thresholds (V_{outOV} and $V_{outOV,red}$).

Figure 26 shows the captured waveform of the adaptive output OVP triggering after disconnecting the LED load, while **Figure 27** shows the captured waveform of the adaptive output OVP exiting after connecting the LED load.

Performance

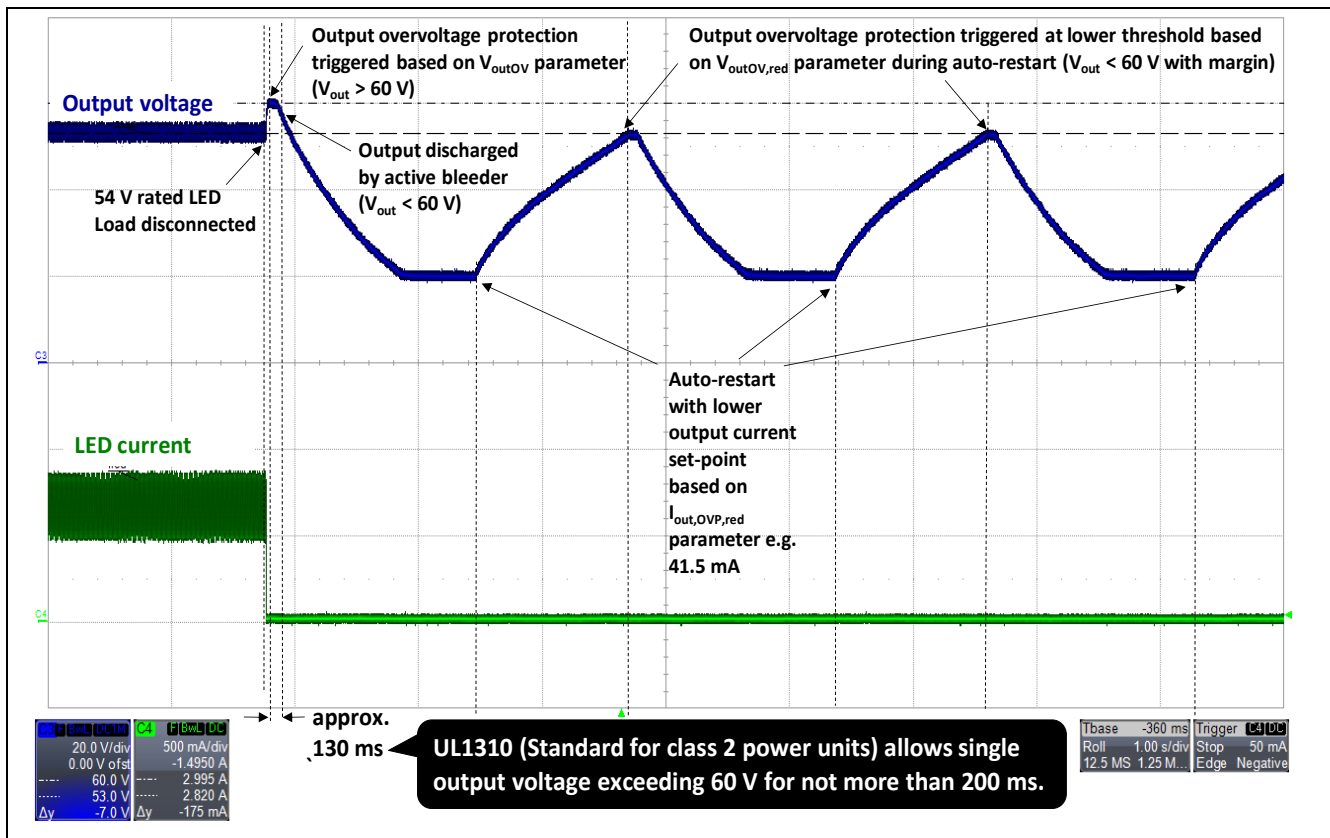

Figure 26 Output OVP triggering with adaptive thresholds (V_{outOV} and $V_{outOV,red}$), after disconnecting the LED load

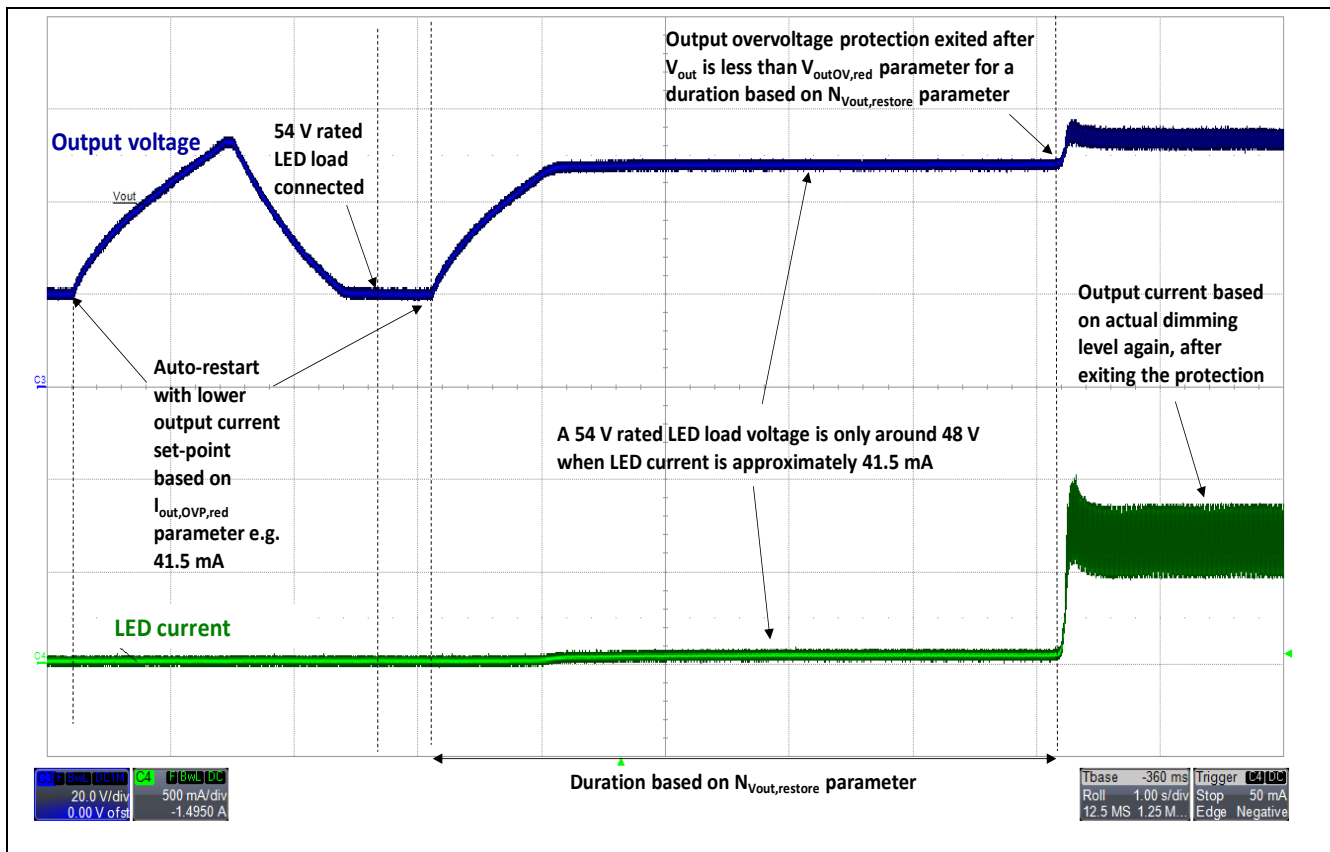

Figure 27 Output OVP exiting after connecting the LED load

6 BOM and transformer specifications

This section provides the BOM and the transformer specifications.

Table 4 BOM of main board

Designator	Value	Part number	Manufacturer
BR1	Bridge rectifier/4 A/1000 V	GBU4M-BP	MCC
C1, C2	0.1 μ F/305 V AC	B32922C3104K	Epcos
C3, C13	SMD size: 1206/1 nF/630 V/COG	GRM31B5C2J102JW01L	Murata
C4, C16, C20, C24	SMD size: 0603/100 nF/50 V/X7R	06035C104K4T4A	AVX
C5	SMD size: 1206/100 pF/50 V/COG	12065A101K4T2A	AVX
C6	E-cap/15 μ F/50 V/20 percent	EEU-FC1H150	Panasonic
C7	220 nF/630 V	ECW-FA2J224JQ	Panasonic
C8	E-cap/22 μ F/100 V/20 percent	UVZ2A220MED1TD	Nichicon
C9	47 pF/50 V/COG	C0603C470J5GAC3112	Kemet
C10	SMD size: 1206/6.8 nF/630 V/X7R	CGA5H4C0G2J682J115AE	TDK
C11	470 p/500 V AC RAD	VY1471K31Y5UQ6TV0	Vishay
C12	1500 p/500 V AC RAD	VY1152M41Y5UQ6TV0	Vishay
C14	MLCC/4.7 μ F/100 V/10 percent	FG11X7S2A475KRT06	TDK
C17	SMD size: 1206/1 μ F/100 V/X7R	12061C105K4Z2A	AVX
C18, C21	E-cap/470 μ F/80 V/20 percent	ERN1BM471L200T	AiSHi
C19	SMD size: 1206/4.7 μ F/50 V/X7R	CGA5L3X7R1H475K160AE	TDK
C22	SMD size: 1206/22 nF/50 V/X7R	C1206C223K5RACTU	KEMET
C23	SMD size: 0805/1 nF/50 V/COG	C0805C102J5GAC7210	Kemet
C27	SMD size: 0805/100 nF/100 V/X7R	C0805C104K1RAC	Kemet
D1	Standard diode/1 A/1000 V	1N4007RLG	OnSemi
D2	Standard diode/1 A/1000 V	1N4007RLG	OnSemi
D3	ESD diode SOD323	ESD5V0D3-TP	MCC
D4	Small-signal diode 0.2 A/100 V	BAV19W-7-F	Diodes
D7, D9, D10, D11	Fast diode/0.25 A/250 V	BAV103,115	Nexperia
D8	Ultra-fast diode/1 A/800 V	US1K-13-F	Diodes
D12	Hyper-fast diode/15 A/300 V	VS-15ETH03PBF	Vishay
D13	Schottky diode/30 V/200 mA/SOD323	PMEG3002EJ	NXP
F1	Fuse/2 A	MCMSF 2A 250 V	MultiComp
IC1	Digital Flyback controller	XDPL8210	Infineon
IC2	TCLT1103	TCLT1103	Vishay
IC3	Dimming interface IC SOT23-6	CDM10VD	Infineon
J1, J2	20 mm pitch jumper 0.8 mm wire	TCW21 250G	Pro Power
J3, J4, J5	SMD size: 1206/jumper (0 Ω)	RC1206JR-070RL	Yageo/Phycomp
L1	Common mode choke 47 mH/0.7 A	B82732F2701B001	Epcos
L2	Differential choke/470 μ H/1.15 A	7447480471	Würth
MOV2	Varistor/510 V	ERZE08A511	Panasonic
Q1	NPN/1A/100 V, SOT89	2SC3646T-TD-E	OnSemi
Q2	MOSFET/0.9 Ω , 800 V, SOT223	IPN80R900P7	Infineon
Q3	BSS169	BSS169	Infineon
Q4	2N7002	2N7002	OnSemi
Q5	BSS123N	BSS123NH6433XTMA1	Infineon

XDPL8210 CDM10VD 35 W reference design with IPN80R900P7**For LED driver with isolated 0 to 10 V dimming and dim-to-off operation****BOM and transformer specifications**

Designator	Value	Part number	Manufacturer
R3	SMD size: 1206/16 k Ω /1 percent/0.25 W	ERJ-8ENF1602V	Panasonic
R4, R5	SMD size: 1206/18 k Ω /1 percent/0.25 W	ERJ-8ENF1802V	Panasonic
R6	SMD size: 1206/4.7 k Ω /1 percent/0.25 W	CRCW12064K70FKEA	Vishay
R7	SMD size: 1206/20 k Ω /1 percent/0.25 W	WR12X2002FTL	Walsin
R8	SMD size: 1210/1 Ω /1 percent	CRM1206-FX-1R00ELF	Bourns
R9, R10	SMD size: 1210/150 k Ω /1 percent/0.5 W	ERJ14NF1503U	Panasonic
R11	SMD size: 1206/56.2 k Ω /1 percent/0.25 W	CRCW120656K2FKEA	Vishay
R12	SMD size: 0603/ 2.7 k Ω /1 percent	WR06X2701FTL	Walsin
R13	SMD size: 1206/10 Ω /1 percent/0.25 W	RC1206FR-0710RL	Yageo/Phycomp
R14	SMD size: 0603/20 k Ω /1 percent	ERJ-3EKF2002V	Panasonic
R15	SMD size: 1206/300 k Ω /1 percent/0.25 W	WCR1206-300KFI	Welwyn
R16	SMD size: 1210/0.22 Ω /1 percent/1 W	RCWE1210R220FKEA	Vishay
R17	SMD size: 0603/47 k Ω /1 percent	ERJ-3EKF4702V	Panasonic
R18	SMD size: 1206/0 Ω	C1206JR-070RL	Yageo/Phycomp
R20	SMD size: 0603/39 k Ω /1 percent	ERJ-3EKF3902V	Panasonic
R21	SMD size: 3216/200 k Ω /1 percent/0.25 W	MCWR12X2003FTL	MultiComp
R22	SMD size: 0805/330 k Ω /1 percent	MCWF08P3303FTL	MultiComp
R23	SMD size: 0805/200 k Ω /1 percent	CRCW0805200KFKEAC	Vishay
R24, R25, R26	SMD size: 3225/3.0 k Ω /0.5 W	CRCW12103K00FKEA	Vishay
R27	SMD size: 1206/0 Ω	RC1206JR-070RL	Yageo/Phycomp
R28	SMD size: 0603/1 M Ω /1 percent/0.1 W	CRCW06031M00FKEAC	Vishay
R29	SMD size: 0805/0 Ω	RC0805JR-070RL	Yageo/Phycomp
R30	SMD size: 0603/0 Ω	RC0603FR-070RL	Yageo/Phycomp
R32, R33	SMD size: 1206/10 M Ω /1 percent/0.25 W	RCV120610M0FKEA	Vishay
T1	PQ2020; Lp = 566 μ H; Np = 58; Ns = 17; Na = 15; Nsec_aux = 15	750343465 Rev00	Würth
X1	250 to 203	250-203	WAGO
X2	Post header, 2.54 mm pitch, 3-pin, vertical, single row	MC34631	MultiComp
X3	250 to 204	250-204	WAGO
ZD1	Zener, 16 V, 5 percent	BZX384-C16	NXP
ZD2, ZD3, ZD5	Zener, 12 V, 5 percent	BZX384C12-E3-08	Vishay
ZD4	Zener, 18 V, 2 percent	BZX384B18-E3-08	Vishay

XDPL8210 CDM10VD 35 W reference design with IPN80R900P7
For LED driver with isolated 0 to 10 V dimming and dim-to-off operation
BOM and transformer specifications

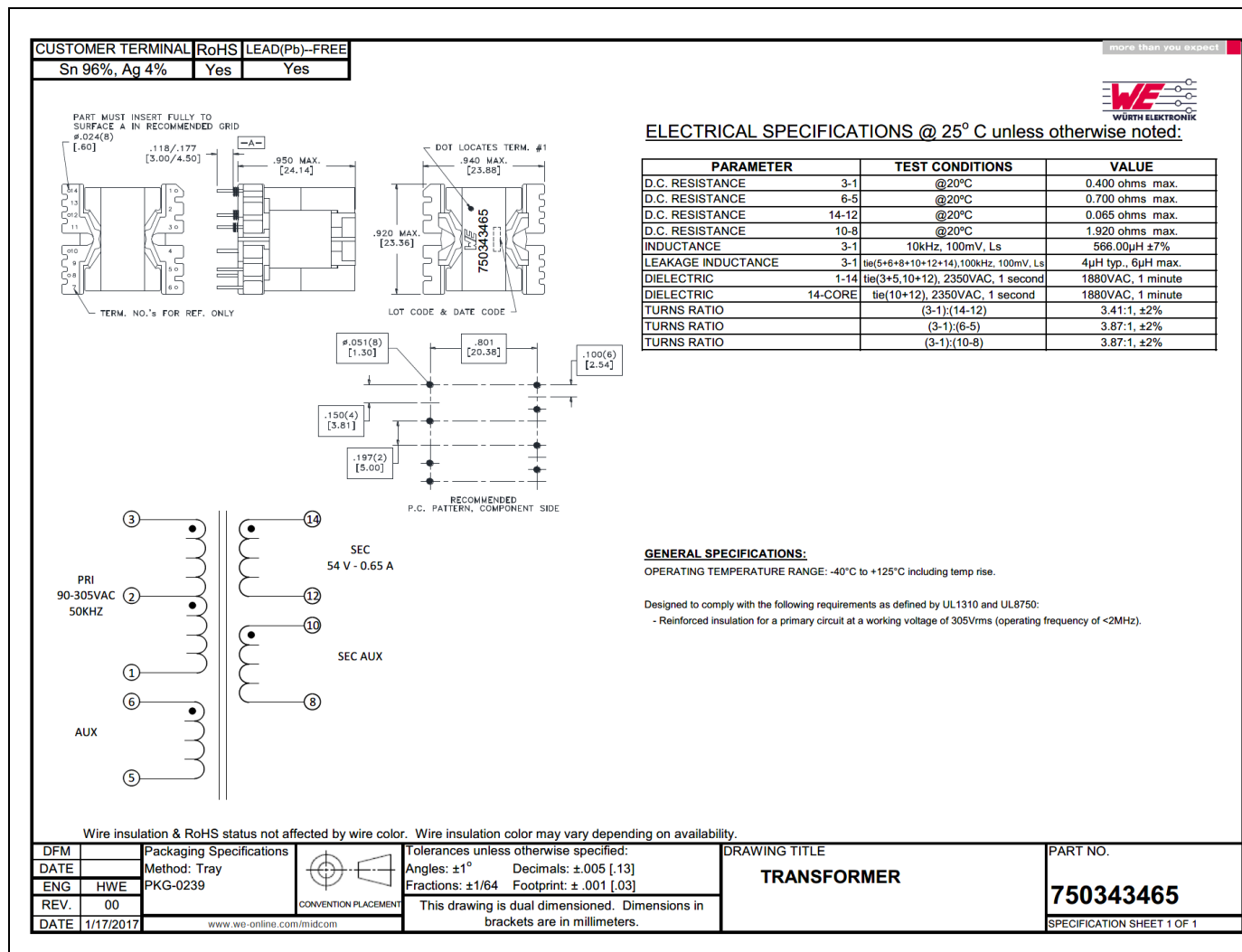

Figure 28 Flyback transformer (T1) specifications

7 References

[1] XDPL8210 datasheet

References

Revision history

Document version	Date of release	Description of changes
V 1.1	2021-07-01	Change C22 value from 220 nF to 22 nF in schematic and BOM Remove “and DC input with 127 V to 432 V” text from Section 2
V 1.0	2019-02-14	Initial version

Trademarks

All referenced product or service names and trademarks are the property of their respective owners.

Edition 2021-07-01

Published by

Infineon Technologies AG

81726 Munich, Germany

© 2021 Infineon Technologies AG.

All Rights Reserved.

Do you have a question about this document?

Email: erratum@infineon.com

Document reference

ER_1902_PL21_1903_042903

IMPORTANT NOTICE

The information contained in this application note is given as a hint for the implementation of the product only and shall in no event be regarded as a description or warranty of a certain functionality, condition or quality of the product. Before implementation of the product, the recipient of this application note must verify any function and other technical information given herein in the real application. Infineon Technologies hereby disclaims any and all warranties and liabilities of any kind (including without limitation warranties of non-infringement of intellectual property rights of any third party) with respect to any and all information given in this application note.

The data contained in this document is exclusively intended for technically trained staff. It is the responsibility of customer's technical departments to evaluate the suitability of the product for the intended application and the completeness of the product information given in this document with respect to such application.

For further information on the product, technology, delivery terms and conditions and prices please contact your nearest Infineon Technologies office (www.infineon.com).

WARNINGS

Due to technical requirements products may contain dangerous substances. For information on the types in question please contact your nearest Infineon Technologies office.

Except as otherwise explicitly approved by Infineon Technologies in a written document signed by authorized representatives of Infineon Technologies, Infineon Technologies' products may not be used in any applications where a failure of the product or any consequences of the use thereof can reasonably be expected to result in personal injury.