

TLE49SRC3; TLE49SRP3; TLE49SRS3
XENSIV™ magnetic position sensors
Features

- Intrinsic stray field robustness
- Differential Hall based angle sensor
- 360° angle measurement
- Angle speed information
- PWM, SPC, SENT (based on SAE J2716-2016) interfaces
- Leaded package with integrated capacitors
- Max. +/-1° intrinsic angle error over lifetime and temperature range
- High voltage and reverse polarity capability
- 14 bit over 360° representation of absolute angle value on the output
- EEPROM for storage of configuration (e.g. zero angle) and customer specific ID
- ISO 26262 Safety Element out of Context for safety requirements up to ASIL C(D)
- Look-up table to correct for systematic angle errors (e.g. magnetic circuit)
- SPC Frameholder mechanism
- Single-wire SICI programming interface on output pin
- RoHS compliant and halogen free package

Potential Applications

- Chassis height sensor
- Pedal position sensor
- Throttle position sensor
- Steering angle sensor
- Wiper position sensor

Product Validation

Product validation according to AEC-Q100, Grade 0. Qualified for automotive applications.

Description

The TLE49SR is a stray field robust angle sensor based on Hall technology for measuring absolute angular position in the range from 0° to 360°. The sensor provides digital output interfaces. Spatially separated Hall cells, which enable a stray field robust measurement of the magnetic field, and signal conditioning circuits are implemented on the integrated circuit (IC). The sensor supports PWM, SENT and SPC interfaces and is developed according to ISO 26262 as safety element out of context.

Table 1 Variant Ordering codes

Product Type	Marking	Ordering Code	Package	Comment
TLE49SRP3	49SRP3	SP005398937	PG-SSO-3-41	PWM Interface
TLE49SRS3	49SRS3	SP005398939	PG-SSO-3-41	SENT Interface
TLE49SRC3	49SRC3	SP005398941	PG-SSO-3-41	SPC Interface

Table of contents

	Table of contents	2
1	Block diagram	4
2	Pin configuration	5
3	General product characteristics	6
3.1	Absolute Maximum Ratings	6
3.2	ESD Immunity	7
3.3	Stray Field Robustness	7
3.4	Lifetime and Ignition Cycles	7
3.5	Functional range	8
3.6	Thermal Resistance	9
4	Product features	10
4.1	Functional description	10
4.1.1	Angle Accuracy	10
4.1.2	Interface timing	10
4.2	Electrical characteristics	14
4.3	Internal circuitry for PG-SSO-3-41	14
4.4	External circuitry for PG-SSO-3-41	14
5	Specific module descriptions	15
5.1	Diagnostic functions	15
5.1.1	Magnetic field out of range	15
5.1.2	Under- and overvoltage conditon	15
5.2	Interfaces	16
5.2.1	PWM Interface	16
5.2.2	SENT Interface	18
5.2.2.1	SENT protocol data	21
5.2.2.2	SENT Features	22
5.2.3	SPC Interface	24
5.2.3.1	SPC Bus Mode	26
5.2.3.2	SPC master trigger pulse	26
5.2.3.3	SPC Features	28
5.2.4	SICI programming interface	29
5.3	Programming characteristics	29
5.3.1	Calibration and Look-Up-Table (LUT)	30
5.3.2	Programmable measurement range	32
5.3.3	EEPROM	33
6	Application Information	34
7	Package information	37

8	Revision history	41
	Disclaimer	42

1 Block diagram

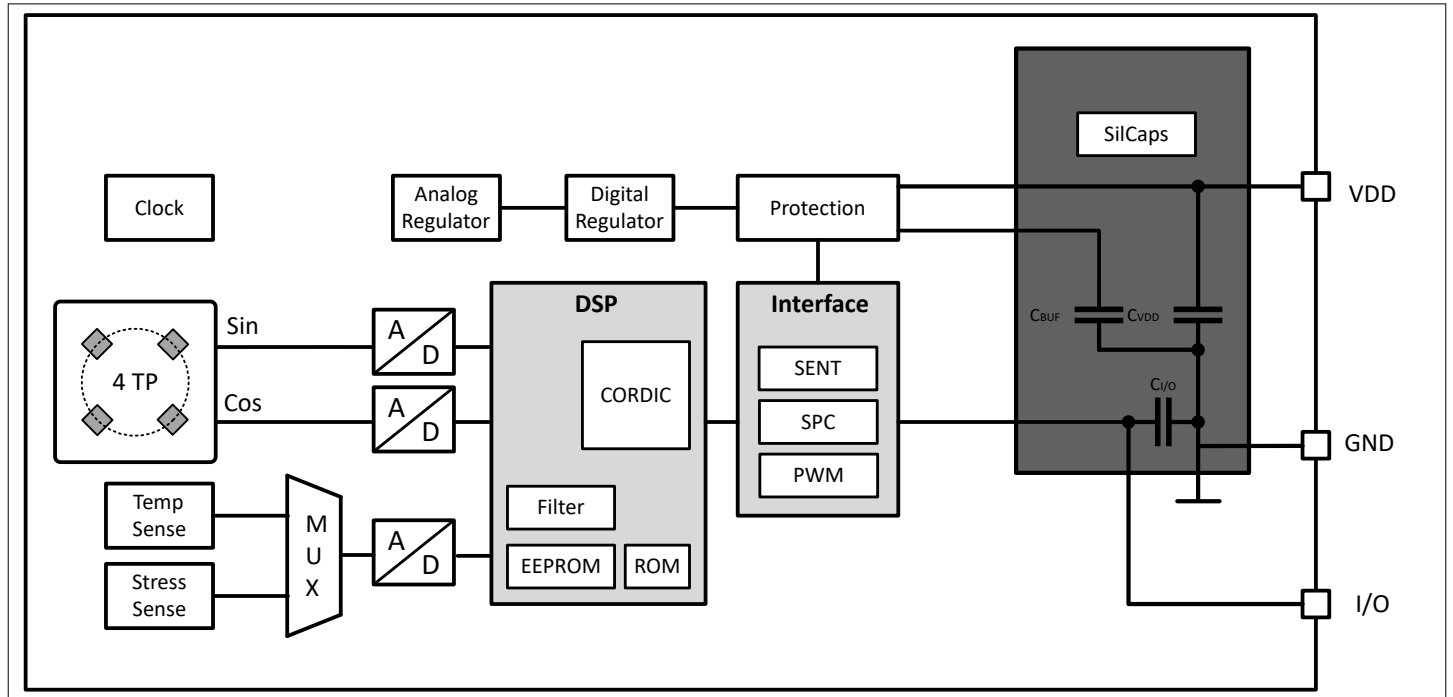

Figure 1 Functional block diagram of TLE49SR

2 Pin configuration

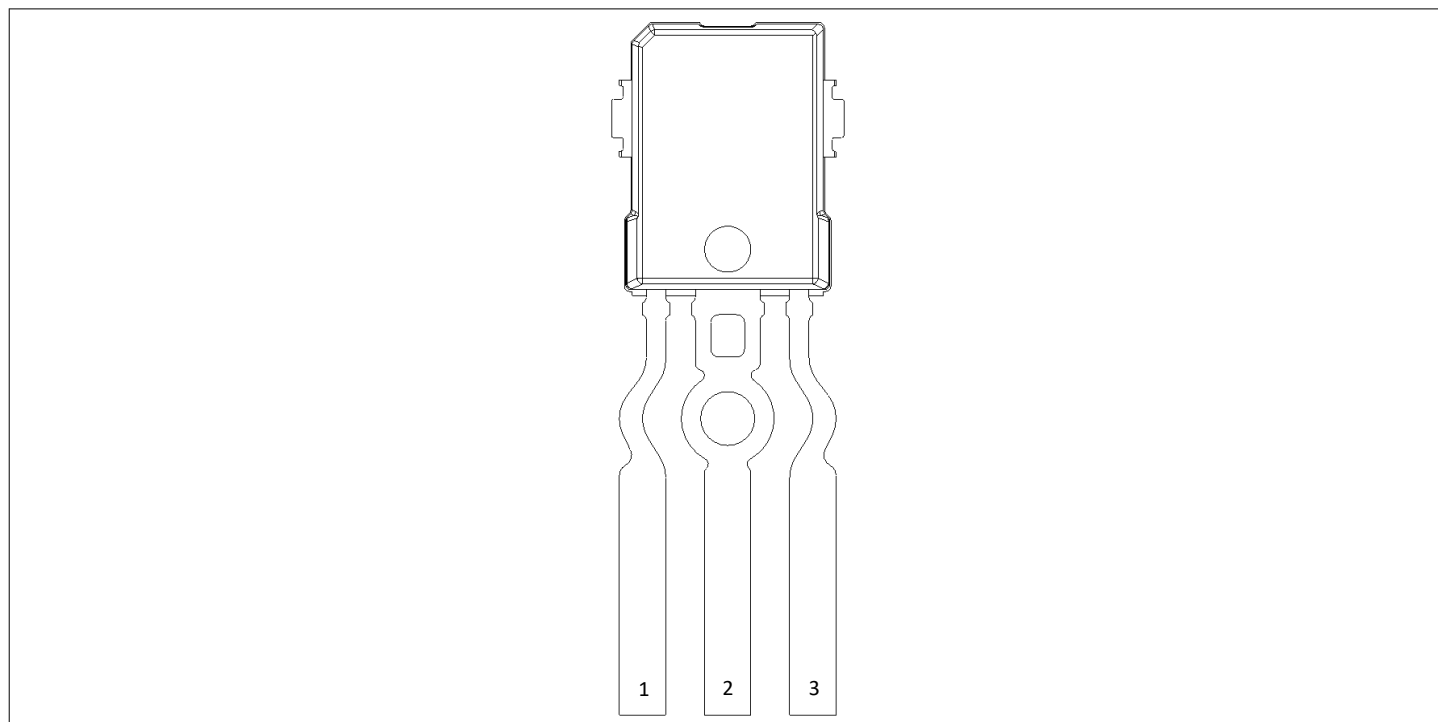

Figure 2 PG-SSO-3-41 Pin configuration

Table 2 Pin configuration PG-SSO-3-41

PIN number	Symbol	Description
1	I/O	PWM/SENT/SPC / programming interface I/O
2	GND	Ground
3	V _{DD}	Supply voltage

3 General product characteristics

3.1 Absolute Maximum Ratings

Table 3 Absolute maximum ratings

Parameter	Symbol	Values			Unit	Note or condition
		Min.	Typ.	Max.		
Maximum supply voltage	V_{DD_max}	-21	-	26	V	max. 1 min @ $T_J = 175^\circ\text{C}$ or max. 1 h @ $T_J = 100^\circ\text{C}$
Maximum voltage I/O	V_{IO_Max}	-18	-	19.5	V	max. 40 h
Voltage peaks VDD	V_{DD_peak}	-	-	30	V	max. 50 μs , no current limitation
Voltage peaks I/O	V_{IO_peak}	-	-	30	V	max. 50 μs , no current limitation
Maximum pin-to-pin voltage difference	V_{PP_max}	-	-	26	V	for neighboring pins
Maximum current VDD	I_{DD_max}	-75	-	45	mA	max. 40 h; current < 0 means short to V_{DD}
Maximum current I/O	I_{IO_max}	-130	-	130	mA	max. 1 h; current > 0 means short to GND, current < 0 means short to V_{DD}
Maximum ambient temperature	T_{A_max}	-40	-	150	$^\circ\text{C}$	max. 1000 h at $T_A=150^\circ\text{C}$ (not additive)
Maximum junction temperature	T_{J_max}	-40	-	175	$^\circ\text{C}$	max. 1000 h at $T_J=175^\circ\text{C}$ (not additive); maximum exposure time at other junction temperatures shall be calculated using the Arrhenius-model
Storage & shipment temperature	$T_{storage}$	5	-	40	$^\circ\text{C}$	for dry packed devices, relative humidity < 90%, storage time < 3a; see Infineon Application Note: “Storage of Products Supplied by Infineon Technologies”

3.2 ESD Immunity

Table 4 ESD immunity

Parameter	Symbol	Values			Unit	Note or condition
		Min.	Typ.	Max.		
HBM ESD immunity	V_{HBM}	-	-	± 4	kV	Electro-Static-Discharge voltage (HBM) according to AEC-Q100-002
CDM ESD immunity	V_{CDM}	-	-	± 0.75	kV	PG-SSO-3-41, the product withstands the specified Electro-Static-Discharge voltage (CDM) according to AEC-Q100-011

Note: Latchup robustness: class II according to AEC-Q100-04.

3.3 Stray Field Robustness

The sensor supports full stray field immunity according to ISO 11452-8:2015 test level IV, and above, see [table 5](#).

Table 5 Stray field robustness

Parameter	Symbol	Values			Unit	Note or condition
		Min.	Typ.	Max.		
Stray field robustness DC	B_{Ext_DC}	-8	-	8	mT	-
Stray field robustness AC	B_{Ext_AC}	-1.25	-	1.25	mT	according ISO 11452-8:2015

3.4 Lifetime and Ignition Cycles

Table 6 Lifetime and ignition cycles

Parameter	Symbol	Values			Unit	Note or condition
		Min.	Typ.	Max.		
Operating lifetime	t_{op_life}	15k	-	-	h	max. 1000 h at $T_{J_max} = 175^{\circ}C$ (not additive)
Total lifetime	t_{tot_life}	19	-	-	a	additional 3a storage time
Ignition cycles	$N_{ignition}$	54k	-	-		during operating lifetime t_{op_life}

3.5 Functional range

Table 7 Operating range

Parameter	Symbol	Values			Unit	Note or condition
		Min.	Typ.	Max.		
Operating junction temperature	T_J	-40	-	175	°C	max. 1000 h at $T_J=175^\circ\text{C}$ (not additive); maximum exposure time at other junction temperatures shall be calculated using the Arrhenius-model
Operating ambient temperature	T_A	-40	-	150	°C	max. 1000 h at $T_A=150^\circ\text{C}$ (not additive); Grade 0 qualification
Operating supply voltage	V_{DD}	4.5	-	5.5	V	-
Output pull-up voltage	$V_{pull-up}$	3.0/4.5	-	5.5	V	the 3.3V pull-up voltage is only valid when the 3.3V bus capability bit is set in the EEPROM
Output leakage current	I_{OUT_Leak}	20	-	120	μA	$V_{DD} = 5\text{V}$ and $0 < V_{pull-up}$
Supply voltage slew rate	V_{DD_slew}	0.1	-	10^8	V/s	the slew rate is the maximum voltage change per time and relates to the application circuit
Operating supply current	I_{DD}	4	13.5	16.5	mA	-
Angle range	α	0	-	360	°	-
Angular resolution	RES	0.022	-	-	°/bit	-

Table 8 Operating magnetic field range

Parameter	Symbol	Values			Unit	Note or condition
		Min.	Typ.	Max.		
Operating magnetic field	B_{op}	20	-	90	mT	magnetic field based on differential field; magnetic field component orthogonal to package surface
Extended operating magnetic field	B_{op_ext}	10	-	20	mT	magnetic field based on differential field; magnetic field component orthogonal to package surface. In extended operating range (between 10 to 20mT) a warning bit is active ¹⁾

1) In extended range the performances are further degraded due to a reduction of the signal-to-noise ratio and signal-to-offset ratio.

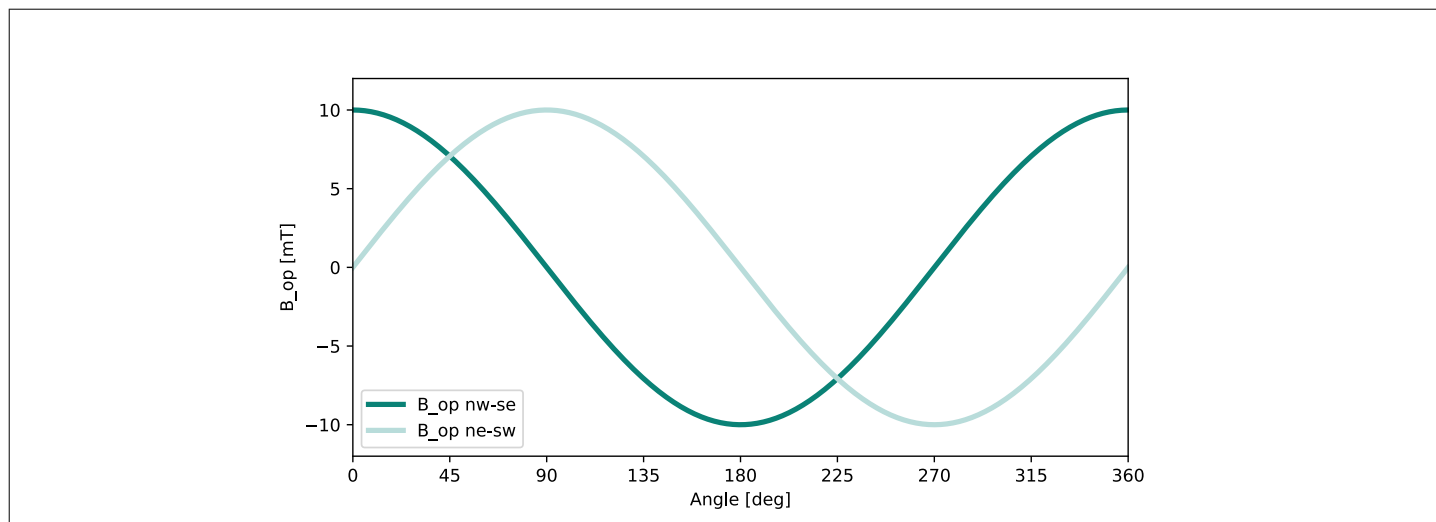

Figure 3 Operating magnetic field example

Table 9 Angle speed

Parameter	Symbol	Values			Unit	Note or condition
		Min.	Typ.	Max.		
Angle speed	n	-	-	10000	rpm	-
Angle speed total error	Δn	-3	-	3	%	for constant velocity at room temperature
Angle speed noise	n RMS	-	-	5	rpm	

Table 10 Angle speed signal attributes

Angle speed mode	$v\alpha 1$	$v\alpha 2$	$v\alpha 3$	$v\alpha 4$	Unit
Measurement range max	± 1000	± 5000	± 4606	± 180000	$^{\circ}/s$
Signal Resolution	12	12	16	16	bit
Latency time	1.0	1.0	1.0	0.5	ms

3.6 Thermal Resistance

Table 11 Thermal resistance

Parameter	Symbol	Values			Unit	Note or condition
		Min.	Typ.	Max.		
Thermal resistance junction to ambient	R_{thJA}	-	150	153	K/W	

4 Product features

4.1 Functional description

4.1.1 Angle Accuracy

The intrinsic angle error includes all errors regarding the IC itself and does not consider mechanical or magnetic tolerances. The mechanic or magnetic tolerances increase the angle error, but can be compensated by an end-of-line multi-point calibration.

Table 12 Angle accuracy

Parameter	Symbol	Values			Unit	Note or condition
		Min.	Typ.	Max.		
Intrinsic angle error	AE _{INL}	-	-	0.8	°	including offset, sensitivity mismatch over temperature assuming an ideal magnetic field
Intrinsic angle error in extended magnetic range	AE _{INL_EXT}	-	-	1.25	°	including offset, sensitivity mismatch over temperature assuming an ideal magnetic field ¹⁾
Intrinsic angle accuracy lifetime drift	AE _{drift}	-	-	0.2	°	-
Output noise (RMS)	OUT _{noise_1k} 5Hz	-	0.05	0.1	°	for LP-Filter setting 8, 20 mT magnetic induction and T _{amb} =25°C

¹⁾ The calculation is derived from characterization and error modeling.

4.1.2 Interface timing

PWM interface timing

The following figure shows the PWM interface timing overview. The raw data is continuously filtered based on the configured filter characteristic. This data is then sampled on an internal trigger shortly before the starting edge of the subsequent PWM frame. Within this fixed period (from trigger to start edge) the angle is calculated using the CORDIC algorithm and the angle data is prepared for transmission. In this way a constant delay of the angle data in respect to the PWM start edge is achieved.

4 Product features

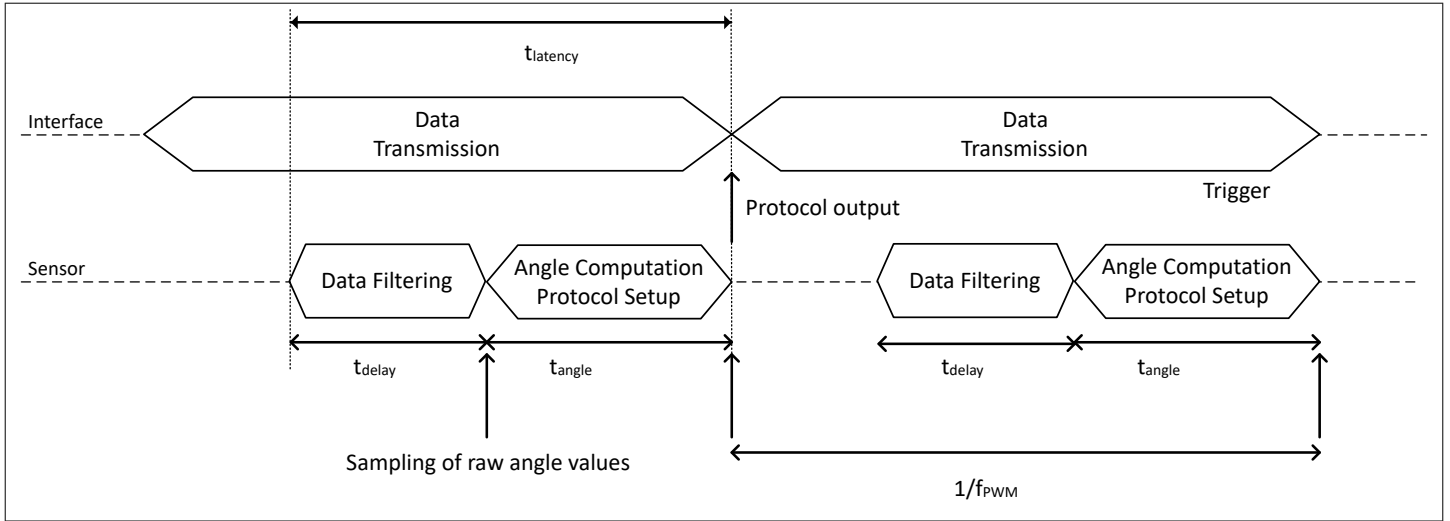

Figure 4 PWM interface timing overview

SENT interface timing

The following figure shows the SENT interface timing overview. The raw data is continuously filtered and sampled with the falling edge of the SYNC nibble, where the angle calculation starts and the output protocol is generated. After finishing the angle calculation, the value is transmitted within the same SENT frame. In this way, a constant delay of the angle data is achieved.

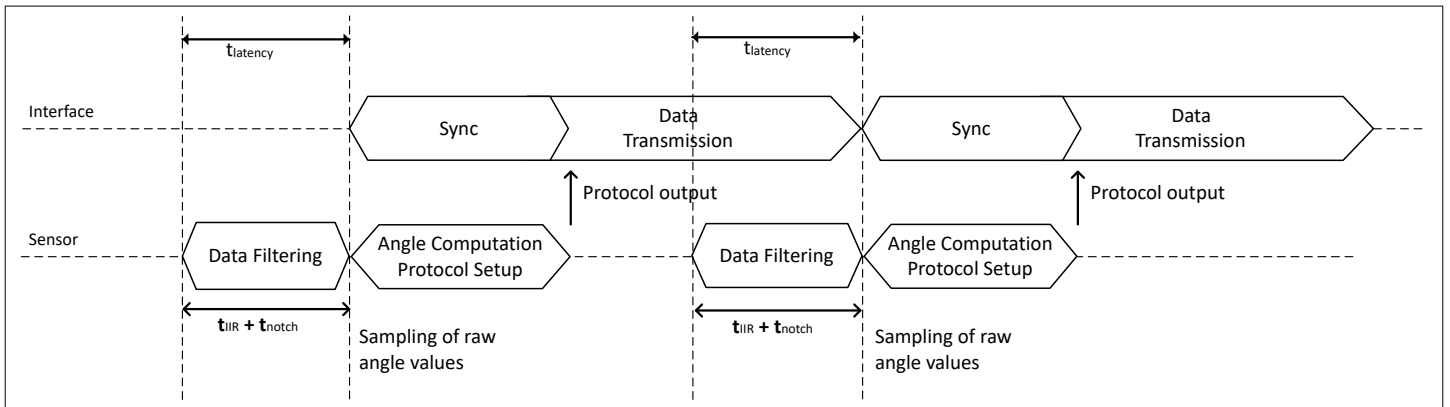

Figure 5 SENT interface timing overview

SPC interface timing

The following figure shows the interface timing overview starting with the trigger event of the SPC interface. The raw data is continuously filtered based on the configured filter characteristic. This data is sampled with the falling edge of the synchronization pulse after a valid SPC trigger is received. The falling edge of the synchronization pulse also starts the angle calculation using the CORDIC algorithm and the setup of the remaining protocol, which is send out after the synchronization pulse within the same SPC frame. In this way, a constant delay of the angle data in respect to the trigger event is achieved.

4 Product features

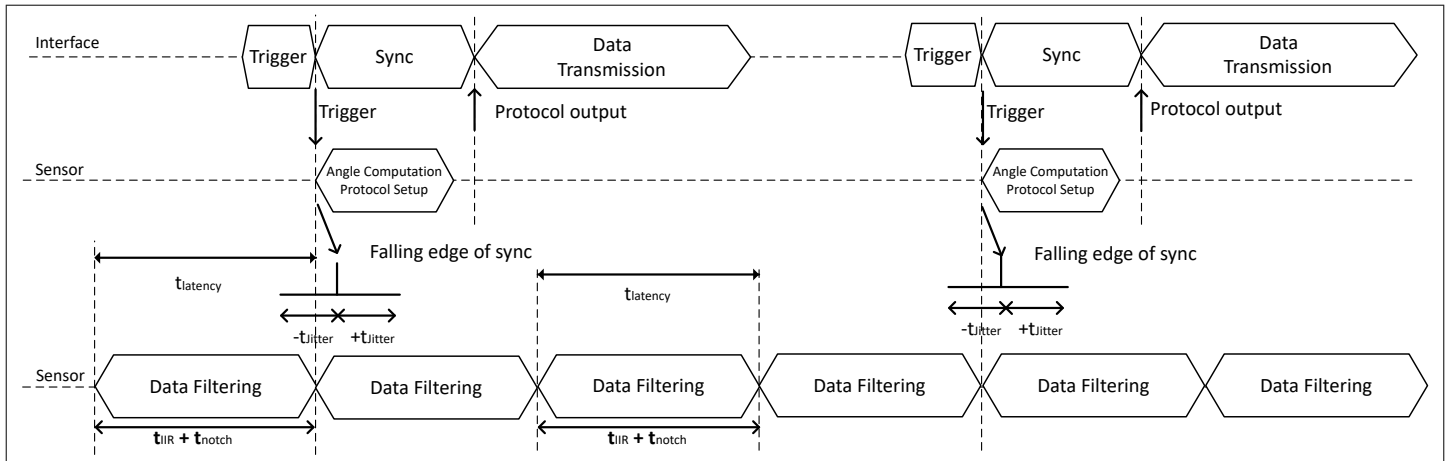

Figure 6 SPC interface timing

Latency time description

The latency time ($t_{latency}$) is obtained by the adding the jitter delay time, the notch filter delay and the signal filter delay: $t_{latency} = t_{jitter} + t_{notch} + t_{IIR}$ (μs).

Note: For the PWM protocol, the angle computation and protocol setup are included in the latency time.

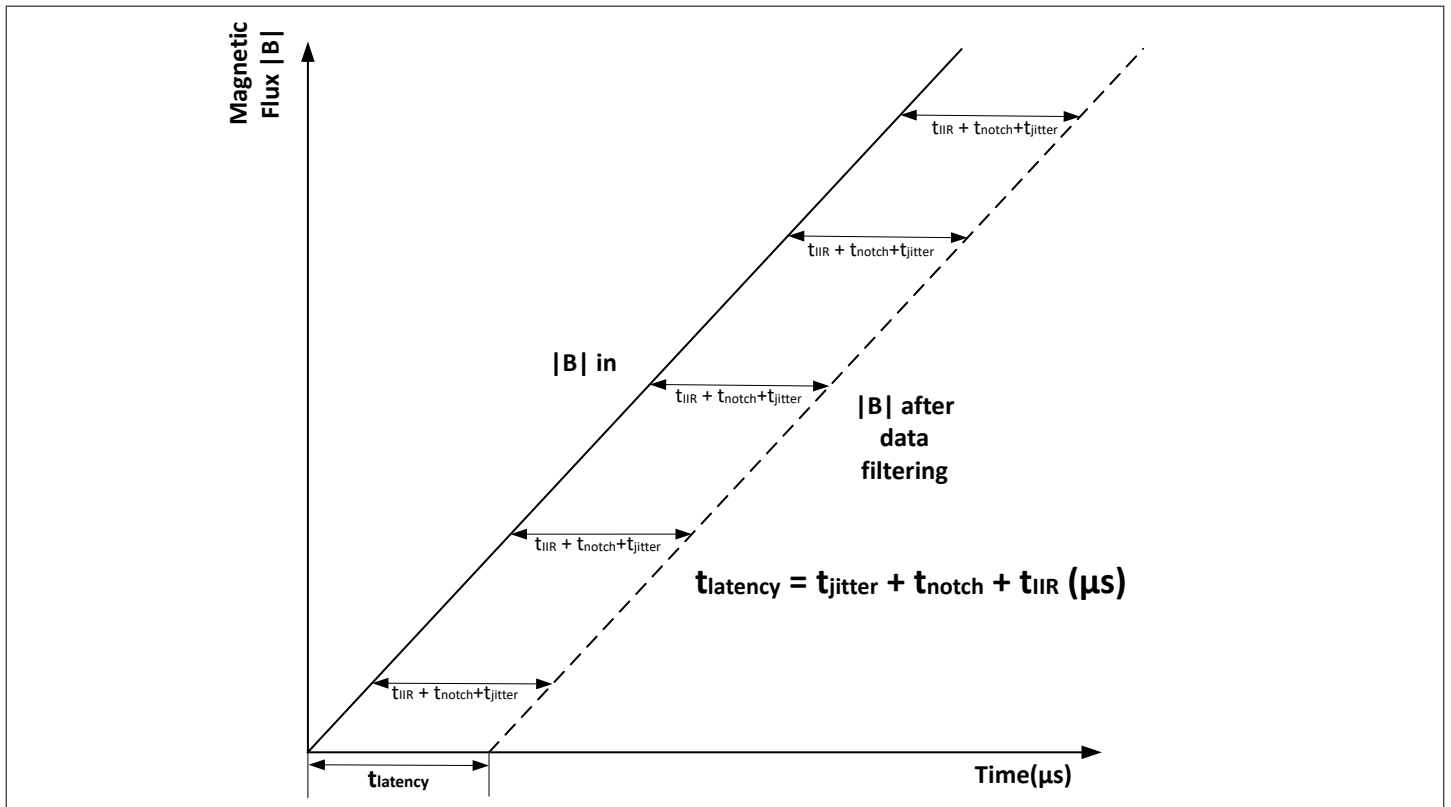

Figure 7 Latency time description

Signal filter time configuration

The sensor allows a configuration of the filter (delay) time through setting the corresponding filter constant k_{filter} .

Table 13 Signal and jitter delay time

Parameter	Symbol	Values			Unit	Note or condition
		Min.	Typ.	Max.		
Jitter delay time	t _{jitter}	-1	-	1	μs	not including interface transmission
Signal filter delay	t _{IIR}	-	-	-	μs	filter setting delay, see Signal filter time configuration
Notch filter delay	t _{notch}	-	-	4.8	μs	
Latency time	t _{latency}	-	-	9.8	μs	for LP-setting 1, see Latency time description

Table 14 Signal filter time configuration

Parameter	Symbol	Values			Unit	Note or condition
		Min.	Typ.	Max.		
Filter setting 1	k _{filter1}	-	-	4	μs	49.2 kHz
Filter setting 2	k _{filter2}	-	-	6.2	μs	32.5 kHz
Filter setting 3	k _{filter3}	-	-	8.3	μs	24.3 kHz
Filter setting 4	k _{filter4}	-	-	12.6	μs	16.1 kHz
Filter setting 5	k _{filter5}	-	-	16.8	μs	12 kHz
Filter setting 6	k _{filter6}	-	-	25.4	μs	8 kHz
Filter setting 7	k _{filter7}	-	-	51	μs	4 kHz
Filter setting 8	k _{filter8}	-	-	136	μs	1.5 kHz (default)
Filter setting 9	k _{filter9}	-	-	204	μs	1 kHz
Filter setting 10	k _{filter10}	-	-	272	μs	0.75 kHz
Filter setting 11	k _{filter11}	-	-	409	μs	0.5 kHz
Filter setting 12	k _{filter12}	-	-	546	μs	0.375 kHz
Filter setting 13	k _{filter13}	-	-	819	μs	0.25 kHz
Filter setting 14	k _{filter14}	-	-	1.64	ms	125 Hz
Filter setting 15	k _{filter15}	-	-	2.18	ms	93 Hz
Filter setting 16	k _{filter16}	-	-	3.27	ms	62 Hz
Filter setting 17	k _{filter17}	-	-	4.36	ms	47 Hz
Filter setting 18	k _{filter18}	-	-	6.54	ms	31 Hz
Filter setting 19	k _{filter19}	-	-	8.72	ms	23 Hz
Filter setting 20	k _{filter20}	-	-	13.1	ms	15 Hz
Filter setting 21	k _{filter21}	-	-	26	ms	7.8 Hz

4.2 Electrical characteristics

Table 15 Electrical characteristics

Parameter	Symbol	Values			Unit	Note or condition
		Min.	Typ.	Max.		
Power-on time	t_{PON}	2	-	198	ms	time until the sensor is ready for operation after start-up or reset; configurable with a resolution of 192 μ s steps
Internal clock tolerance	Δf_{clock}	-3.5	-	3.5	%	including temperature and lifetime

4.3 Internal circuitry for PG-SSO-3-41

Table 16 Internal circuitry for PG-SSO-3-41

Parameter	Symbol	Values			Unit	Note or condition
		Min.	Typ.	Max.		
Capacitance at VDD	C_{VDD}	75	100	125	nF	PG-SSO-3-41, PWM / SENT / SPC interface
Capacitance at I/O pin	C_{IO}	0.975	1.30	1.625	nF	PG-SSO-3-41, for SPC interface: unit time of 0.75 μ s to 3 μ s depending on slope setting
Capacitance at CBUF	C_{BUF}	51	68	85	nF	PG-SSO-3-41

4.4 External circuitry for PG-SSO-3-41

Table 17 External circuitry for PG-SSO-3-41

Parameter	Symbol	Values			Unit	Note or condition
		Min.	Typ.	Max.		
Pull-Up resistor PWM	R_{PU_PWM}	-	50	-	k Ω	for PWM protocol starting with falling edge
Pull-down resistor PWM	R_{PD_PWM}	-	50	-	k Ω	for PWM protocol starting with rising edge
Pull-Up resistor SPC	R_{P_SPC}	1.45	2.2	10	k Ω	for SPC protocol according configured unit time
Pull-Up resistor SENT	R_{P_SENT}	10	-	55	k Ω	for SENT protocol

5 Specific module descriptions

5.1 Diagnostic functions

5.1.1 Magnetic field out of range

The sensor indicates a magnetic field out of the specified range through a warning bit in the status and communication nibble.

5.1.2 Under- and overvoltage conditon

Table 18 Undervoltage and overvoltage conditions

Parameter	Symbol	Values			Unit	Note or condition
		Min.	Typ.	Max.		
Undervoltage detection on VDD	V_{UV}	3.2	-	4.1	V	below this level no protocol is transmitted
Overvoltage detection on VDD	V_{OV}	6.5	-	7.35	V	above this level no protocol is transmitted
Undervoltage reset time	t_{UV}	-	-	50	μ s	time below threshold for the sensor to initiate a safe reaction
Undervoltage hysteresis	V_{UV_hyst}	300	280	500	mV	-
Overvoltage hysteresis	V_{OV_hyst}	100	160	300	mV	-
Overvoltage reaction time	t_{OV_RT}	-	-	50	μ s	time to react to overvoltage condition and disable output
Overvoltage recovery time	t_{OV}	-	-	50	μ s	time after overvoltage condition to enable protocol output
Undervoltage reaction time	t_{UV_RT}	-	-	50	μ s	time to react to unervoltage condition, and disable output
Undervoltage recovery time	t_{UV_RT}	-	-	50 + filter delay	μ s	time after undervoltage condition to enable protocol output

5.2 Interfaces

5.2.1 PWM Interface

The PWM interface is a uni-directional interface with the angle information coded in the length of a pulse. The angle value is proportional to the duty cycle of the output frequency. The duty cycle is calculated as the ratio of the “high” time to the period length. An increasing angle results in an increased duty cycle with an angle of 0° having the smallest duty cycle. The starting edge of the PWM protocol can be programmed as rising or falling edge. In case the protocol starts with a rising edge (LOW level start), a pull-down resistor is required. For the start-up condition with a falling edge (HIGH level start), a pull-up resistor instead has to be implemented. The protocol works in push/pull and open drain configuration.

The tolerance of the programmed PWM frequency over temperature and lifetime is given in the table "PWM Frequency tolerance".

The PWM protocol also allows to use the characteristic curves function, which is primarily utilized in chassis position sensor applications. This function allows the measurement range of 360° to be divided into smaller segments of 90° or 120° (see [Programmable measurement range](#)), however the quadrant information is not transmitted.

Error indication

For diagnostic purpose and to indicate internal sensor failures, the output duty cycle of the PWM is limited. Within this reserved lower and upper duty cycle range, no valid angle information is provided. Instead, this duty cycle range is used for error indication with defined duty cycles which are clearly separated from the usable data duty cycle range. The following events are indicated:

- Occurrence of internal or external fault
- Sensor reset occurred

Configuration

The PWM interface enables to configure the frequency, to define a data duty cycle range and a low and high value of the diagnostic duty cycle. It has to be ensured by proper device configuration that there is no overlap of data duty cycle range and low or high value of diagnostic duty cycle.

A possible and valid configuration is:

- Data duty cycle: 12.5% ...87.5%: the 12bit angle value is mapped to this duty cycle
- Diagnostic duty cycle, low: 5%: Low diagnostic duty cycle for indicating firmware safety check errors, details available in the TLE49SRPx safety manual
- Diagnostic duty cycle, high: 95%: High diagnostic duty cycle for indicating hardware related errors, details available in the TLE49SRPx safety manual

The PWM interface with data duty cycle range and reserved duty cycle for diagnostics is shown in figure "PWM interface with duty cycle range starting with a rising edge".

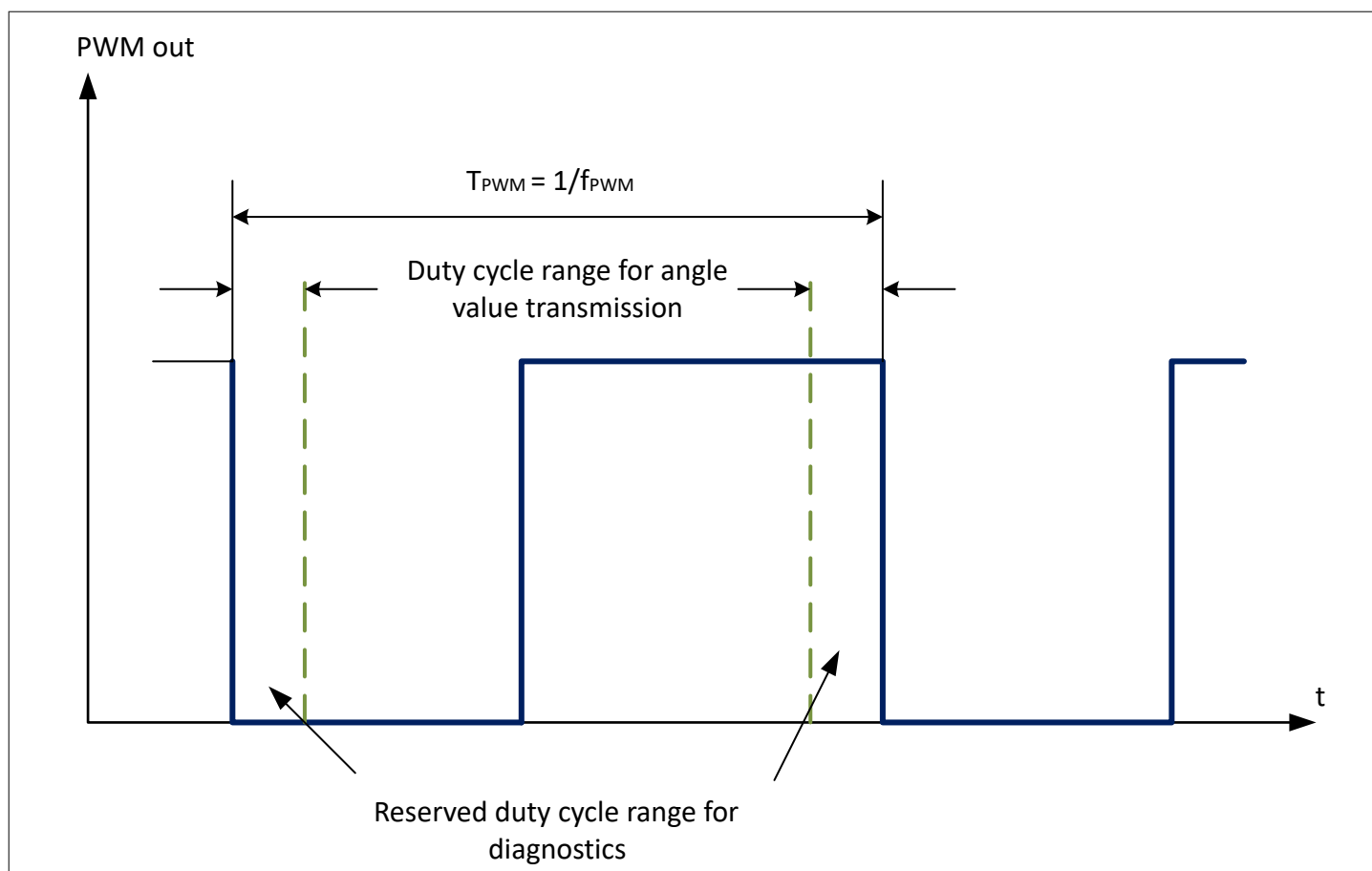

Figure 8 PWM interface with duty cycle range starting with a rising edge

As the PWM interface is an analog protocol, the rise and fall times, as well as the trigger level for the detection of the high and low state of the signal have influence on the measured duty cycle. Therefore, an additional angle error is introduced which varies with the measurement conditions (e.g. R_p , CW, trigger level). This error contribution is not included in the angle error definition.

Table 19 PWM interface parameters

Parameter	Symbol	Values			Unit	Note or condition
		Min.	Typ.	Max.		
Data resolution	-	12	-	-	bit	-
Output frequencies	f_{PWM}	200	-	3000	Hz	configurable in steps of 1Hz; frequency depending rise/fall time inaccuracies result in additional angle error
Output frequency tolerance	PWM_{freq_tol}	-	-	± 5	%	-
Maximum data duty cycle range	DC_{data_max}	5	-	95	%	configurable, the 12 bit angle value is mapped to this duty cycle range
High diagnostic duty cycle	DC_{diag_high}	75	-	99	%	high time to period; $f < 2\text{kHz}$ PWM frequency

(table continues...)

Table 19 (continued) PWM interface parameters

Parameter	Symbol	Values			Unit	Note or condition
		Min.	Typ.	Max.		
High diagnostic duty cycle ($f \geq 2\text{kHz}$)	$DC_{\text{diag_high},>2\text{kHz}}$	85	-	99	%	high time to period; $f \geq 2\text{kHz}$ PWM frequency
Low diagnostic duty cycle	$DC_{\text{diag_low}}$	1	-	25	%	high time to period; $f < 2\text{kHz}$ PWM frequency
Low diagnostic duty cycle ($f \geq 2\text{kHz}$)	$DC_{\text{diag_low},>2\text{kHz}}$	1	-	15	%	high time to period; $f \geq 2\text{kHz}$ PWM frequency
Minimum data duty cycle range	$DC_{\text{data_min}}$	29	-	71	%	high time to period; $f < 2\text{kHz}$ PWM frequency
Minimum data duty cycle range ($f \geq 2\text{kHz}$)	$DC_{\text{data_min},>2\text{kHz}}$	19	-	81	%	high time to period; $f \geq 2\text{kHz}$ PWM frequency

5.2.2 SENT Interface

The sensor supports a SENT (Single Edge Nibble Transmission) interface according to SAE J2716 v.2016-04.

SENT interface description

The SENT interface is a standardized, uni-directional digital protocol. The information is coded in nibbles with different length. One nibble contains 4 bit of information.

The unit time (UT) and nibble low time are configurable. This can reduce the overall frame length. The low time includes the fall time of the edge. It has to be ensured that the fall time of the edge is fast enough to reach the low level within the configured low time.

Table 20 SENT Configuration Parameters

Parameter	Symbol	Values			Unit	Note or condition
		Min.	Typ.	Max.		
SENT unit time	UT	0.75	-	3.0	μs	default 3.0 μs , configurable steps (0.75, 1, 1.25, 1.5, 2.0, 2.5, 3.0), tolerance given by clock tolerance
SENT nibble low time	t_{low}	3	-	5	UT	including the fall time of the edge.

Standard sensor:

The protocol consists of the following nibbles

- A synchronization period (56 UT)
- A status nibble of 12-27 UT, with optional short serial message information
- 3 or 4 data nibbles of 12-27 UT, transmitting the angle value or the angle speed (configurable in EEPROM)
- Optional 2 temperature nibbles of 12-27 UT each (configurable in EEPROM)
- Optional 1 nibble (4 bit) rolling counter of 12-27 UT

5 Specific module descriptions

- A CRC nibble of 12-27 UT
- Optional a pause pulse

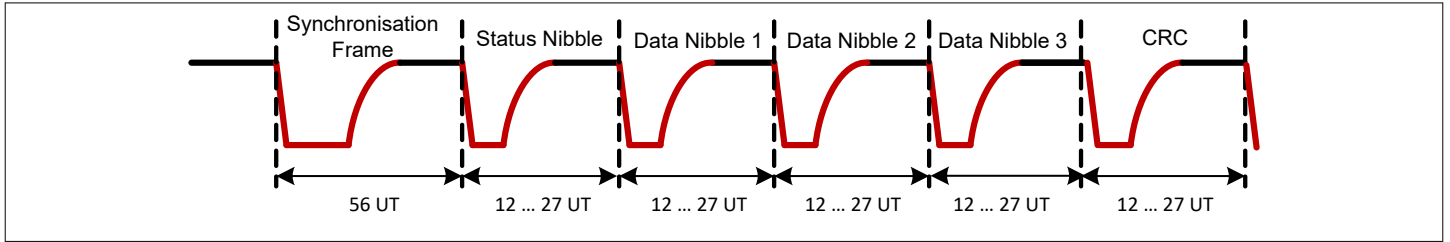

Figure 9 SENT standard frame

Single secure sensor:

The protocol consists of following nibbles

- A synchronization pulse (56UT)
- A status nibble of 12-27 UT
- 3 data nibbles of 12-27 UT, transmitting a 12bit angle value
- 2 nibbles with a 8bit rolling counter information
- 1 nibble as the inverted 1st data nibble
- A CRC nibble of 12-27 UT
- A pause pulse, this is optional and can be deactivated
- A short serial message, this is optional and can be deactivated

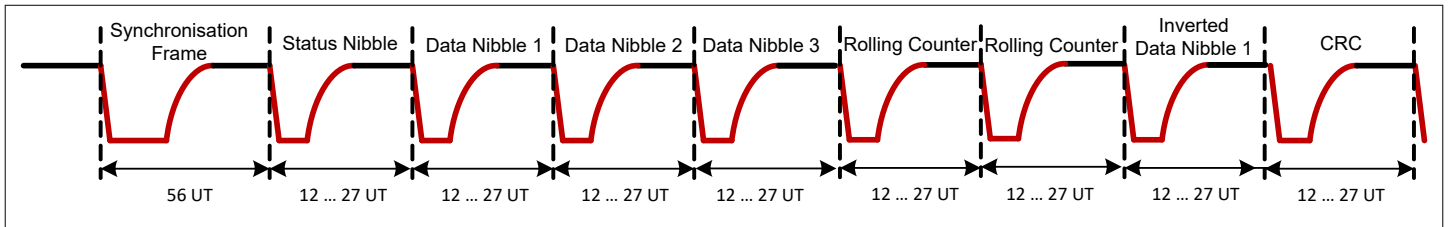

Figure 10 SENT single secure frame

SENT nibble low time

The nibble low time t_{low} can be configured to be 3UT or 5UT. This can reduce the overall frame length. The low time includes the fall time of the edge, therefore it has to be ensured that the fall time of the edge is fast enough to reach the low level within the configured low time ([SENT Configuration Parameters \[EC-Table\]](#)).

Note: A nibble low time of 3UT is not compliant with the SENT standard SAE J2716 JAN2010.

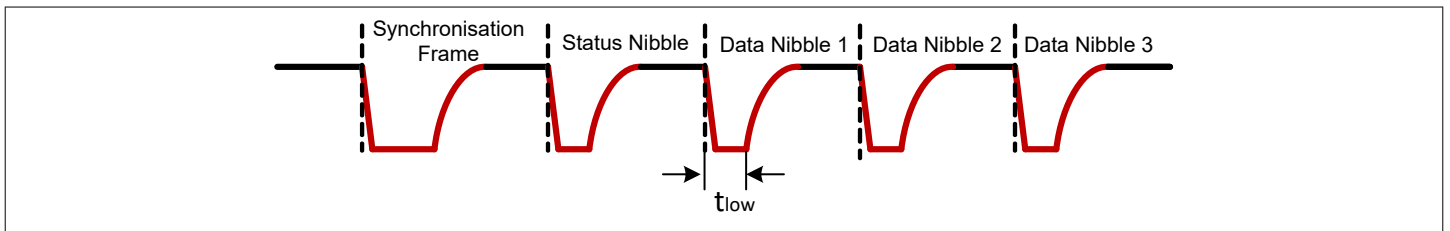

Figure 11 SENT nibble low time

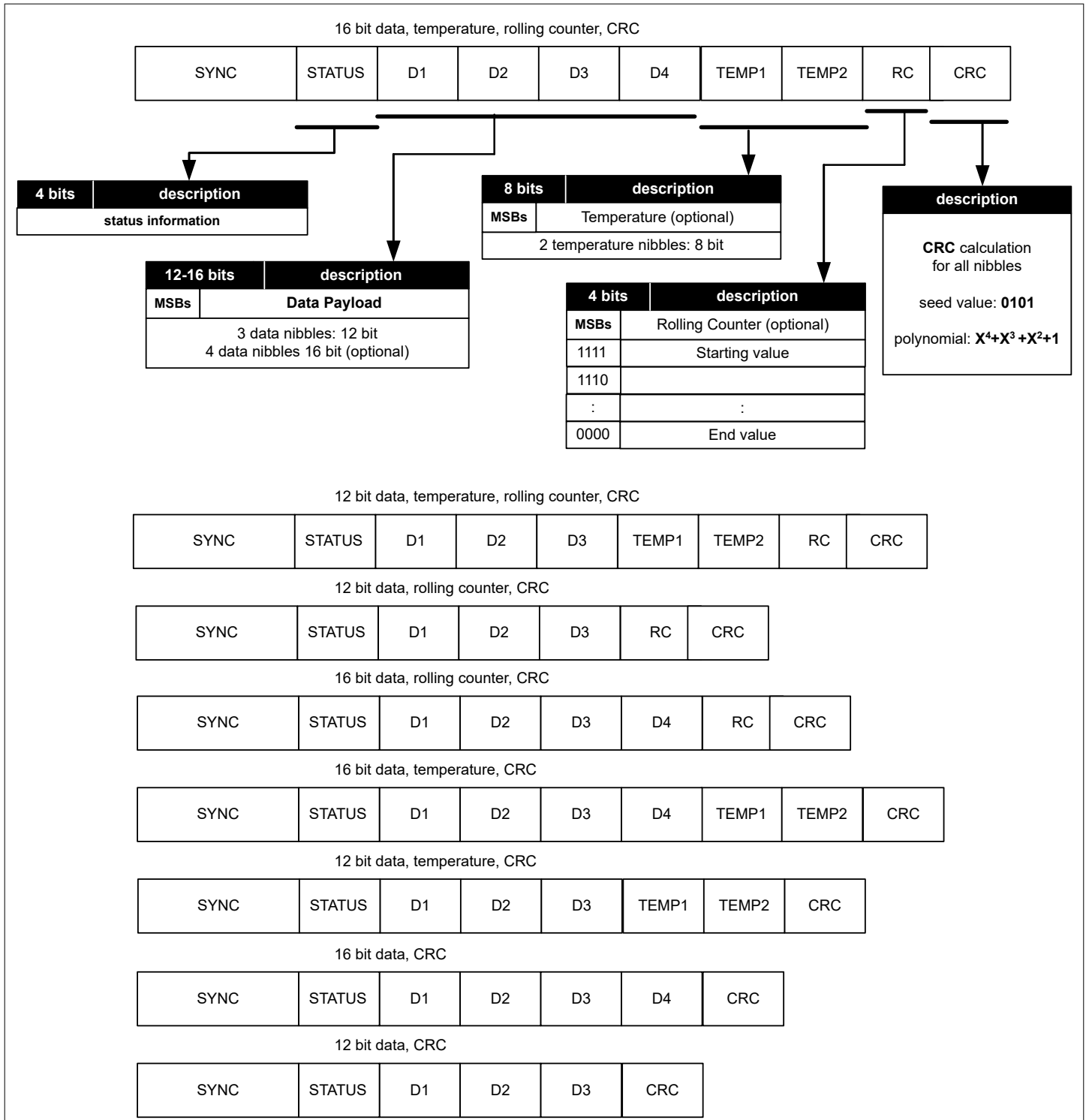

Figure 12 SENT frame options

5.2.2.1 SENT protocol data

Based on the different settings the protocol data content in the nibbles D1 to D4 will be different, in addition to angle value information (as shown above), the user can select to transmit the also angle characteristic curve quadrant information, and or the angle speed information.

Below all combinations of these parameters and the corresponding protocol data content is displayed. The content is the same for the SENT and SPC protocols.

Table 21 Angle value for 90° characteristic curve

SENT/S PC data payload	Data [LSB]	Bitfield Bits	D1				D2				D3				D4				Angle Resoluti on
			15	14	13	12	11	10	9	8	7	6	5	4	3	2	1	0	
12-Bit	angle value	13:4	-	-	13	12	11	10	9	8	7	6	5	4	-	-	-	-	0.088 °/LSB
	quadrant info	1:0	1	0	-	-	-	-	-	-	-	-	-	-	-	-	-	-	
16-Bit	angle value	13:0	-	-	13	12	11	10	9	8	7	6	5	4	3	2	1	0	0.005 °/LSB
	quadrant info	1:0	1	0	-	-	-	-	-	-	-	-	-	-	-	-	-	-	

Table 22 Angle value for 120° characteristic curve

SENT/S PC data payload	Data [LSB]	Bitfield Bits	D1				D2				D3				D4				Angle Resoluti on
			15	14	13	12	11	10	9	8	7	6	5	4	3	2	1	0	
12-Bit	angle value	13:4	-	-	13	12	11	10	9	8	7	6	5	4	-	-	-	-	0.117 °/LSB
	quadrant info	1:0	1	0	-	-	-	-	-	-	-	-	-	-	-	-	-	-	
16-Bit	angle value	13:0	-	-	13	12	11	10	9	8	7	6	5	4	3	2	1	0	0.007 °/LSB
	quadrant info	1:0	1	0	-	-	-	-	-	-	-	-	-	-	-	-	-	-	

Table 23 Angle value for 360° characteristic curve

SENT/SP C data payload	Data [LSB]	Bitfield Bits	D1				D2				D3				D4				Angle Resolutio n
			15	14	13	12	11	10	9	8	7	6	5	4	3	2	1	0	
12-Bit	angle value	15:4	15	14	13	12	11	10	9	8	7	6	5	4	-	-	-	-	0.088 °/LSB
16-Bit	angle value	15:0	15	14	13	12	11	10	9	8	7	6	5	4	3	2	1	0	0.005 °/LSB

Table 24 Angle speed value for mode $\nu\alpha 1$ (+-1000 °/s)

SENT/SPC data payload	Data [LSB]	Bitfield bits	D1				D2				D3				D1				Angle resolution
			15	14	13	12	11	10	9	8	7	6	5	4	3	2	1	0	
12-Bit	angle speed	15:4	11	10	9	8	7	6	5	4	3	3	1	0	-	-	-	-	0.488 °/s/LSB
16-Bit	angle speed	11:0	-	-	-	-	11	10	9	8	7	6	5	4	3	2	1	0	0.488 °/s/LSB

Table 25 Angle speed value for mode $\nu\alpha 2$ (+-5000 °/s)

SENT/SPC data payload	Data [LSB]	Bitfield bits	D1				D2				D3				D1				Angle resolution
			15	14	13	12	11	10	9	8	7	6	5	4	3	2	1	0	
12-Bit	angle speed	15:4	11	10	9	8	7	6	5	4	3	3	1	0	-	-	-	-	2.442 °/s/LSB
16-Bit	angle speed	11:0	-	-	-	-	11	10	9	8	7	6	5	4	3	2	1	0	2.442 °/s/LSB

Table 26 Angle speed value for mode $\nu\alpha 3$ (+-4606 °/s)

SENT/SPC data payload	Data [LSB]	Bitfield bits	D1				D2				D3				D1				Angle resolution
			15	14	13	12	11	10	9	8	7	6	5	4	3	2	1	0	
12-Bit	angle speed	15:4	15	14	13	12	11	10	9	8	7	6	5	4	-	-	-	-	2.249 °/s/LSB
16-Bit	angle speed	15:0	15	14	13	12	11	10	9	8	7	6	5	4	3	2	1	0	0.141 °/s/LSB

Table 27 Angle speed value for mode $\nu\alpha 4$ (+-180000 °/s)

SENT/SPC data payload	Data [LSB]	Bitfield bits	D1				D2				D3				D1				Angle resolution
			15	14	13	12	11	10	9	8	7	6	5	4	3	2	1	0	
12-Bit	angle speed	15:4	15	14	13	12	11	10	9	8	7	6	5	4	-	-	-	-	87.89 °/s/LSB
16-Bit	angle speed	15:0	15	14	13	12	11	10	9	8	7	6	5	4	3	2	1	0	5.493 °/s/LSB

5.2.2.2 SENT Features

Table 28 Structure of SENT status nibble

Bits	Description
[0] LSB	Error indication or sensor reset
[1]	Warning bit (e.g. air gap warning or OV/UV indication)
[2]	Short serial message bit (data bit) or 0 if SSM is disabled

(table continues...)

Table 28 (continued) **Structure of SENT status nibble**

Bits	Description
[3] MSB	Short serial message bit (start indication) or 0 if SSM is disabled

Note: For more information about the warning bit and the error indication bit please consult the TLE49SR user manual.

Checksum nibble details

The checksum nibble is a 4-bit CRC of the data nibbles. Optionally the status nibble can be included by register setting. The CRC is calculated using a polynomial $x^4 + x^3 + x^2 + 1$ with a seed value of 0101B. The remainder after the last data nibble is transmitted as CRC.

Short serial message

The short serial message is an additional option which can be enabled and disabled. The short serial message provides additional information in the status nibble by transmitting an 8 bit temperature value, and a 52 bit user and sensor ID.

1 short serial message will be constructed out of 16 SENT frames. In each SENT frame, one bit of information is transmitted in bit [2] of the status nibble and has following structure:

- 4 bit message ID
- 8 bit data
- 4 bit CRC (calculated from message ID and data bits)

The start of the short serial message is indicated by a “1” in bit [3] of the status nibble. For the next 15 frames, this bit will contain a “0”.

The message ID is used for identification of the type of data received. All data are transmitted in the bit [2] of the status nibble in the order MSB to LSB.

Rolling counter

The rolling counter counts the number of transmitted frames with rollover back to 0 and increment with each message. This counter is for verification in the ECU that no frame is missed or that no frame is sent repeatedly from the sensor.

Temperature information

The temperature is coded as an 8 bit value. This value is transferred in unsigned integer format and corresponds to the range between -55°C and +200°C, so a transferred value of 55 corresponds to 0°C. The following table shows the mapping between junction temperature and the transmitted value.

Table 29 **Mapping of temperature value**

Junction temperature	Typical decimal value from sensor	Note
-55°C	0 LSB	theoretical lower limit
0°C	55 LSB	-
25°C	80 LSB	-
200°C	255 LSB	theoretical upper limit

Pause Pulse

There is an optional pause pulse which can be activated or deactivated via corresponding bits in the register.

The following pause pulse modes are available:

- no additional pause pulse
- additional pause pulse of minimum 12 UT generated to guarantee minimum firmware execution time between two protocol frames
- additional pause pulse of minimum 12 UT generated for an overall fixed frame length of 312 UT for all frame formats

5.2.3 SPC Interface

The sensor supports a SPC (Short PWM Code) interface according to version 1.0 with additional enhancements.

SPC interface description

The Short PWM Code (SPC) is a synchronized data transmission based on the SENT protocol (Single Edge Nibble Transmission) defined by SAE J2716. As opposed to SENT, which implies a continuous transmission of data, the SPC protocol transmits data only after receiving a specific trigger pulse from the microcontroller. The required length of the trigger pulse depends on the sensor number, which is configurable. SPC allows the operation of up to four sensors on one bus line.

For the SPC interface the push-pull setting with controlled slopes is used (the push-pull mode is only active during the slope controlled mode). In this configuration, the sensor has controlled rising and falling slopes. Between the slope controlled transitions the HIGH level is maintained by the external pull-up resistor. Once the SPC protocol telegram is sent, the sensor goes in to receiving mode (OUT Pin in Tri-state mode) and waits until a valid trigger signal is received. The sensor is available for the next sample after the falling edge of the end pulse. The sensor's sampling time is at the beginning of the synchronization period, i.e. when a correct trigger is received.

As in SENT, the time between two consecutive falling edges defines the value of a 4-bit nibble representing numbers between 0 and 15. The transmission time therefore depends on the transmitted data values. All values are defined using a unit time frame concept.

SPC frame

The protocol consists of the following nibbles:

- A trigger pulse from the master (microcontroller), which initiates the data transmission
- A synchronization period of 56 UT
- A status nibble of 12-27 UT, with optional short serial message transmission
- 3 or 4 data nibbles of 12-27 UT, transmitting the angle value or the angle speed (configurable in EEPROM)
- Optional 2 temperature nibbles of 12-27 UT each (configurable in EEPROM)
- Optional 1 nibble (4 bit) rolling counter of 12-27 UT
- A CRC nibble of 12-27 UT (configurable in EEPROM)
- An end pulse to terminate the SPC transmission (12 UT)

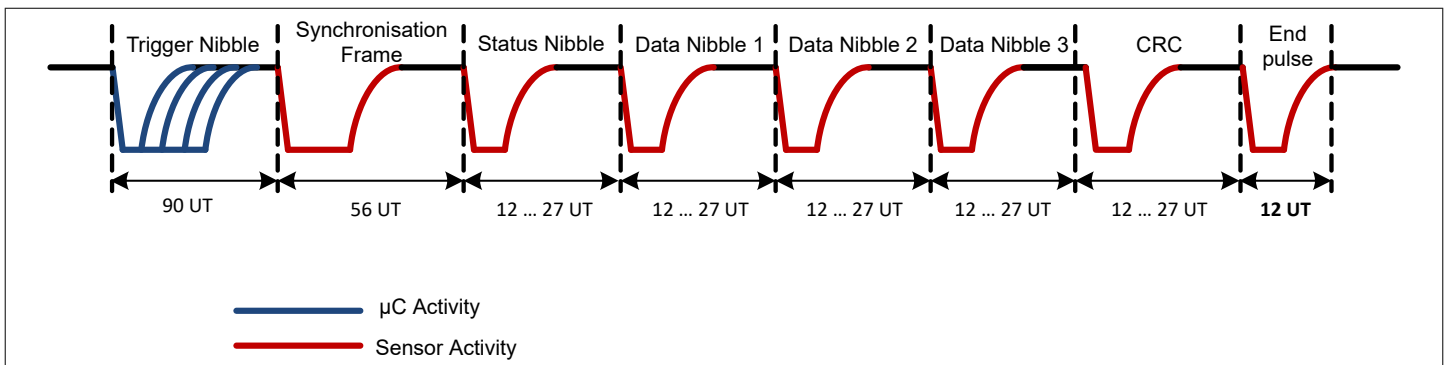

Figure 13 SPC frame with 3 data nibbles

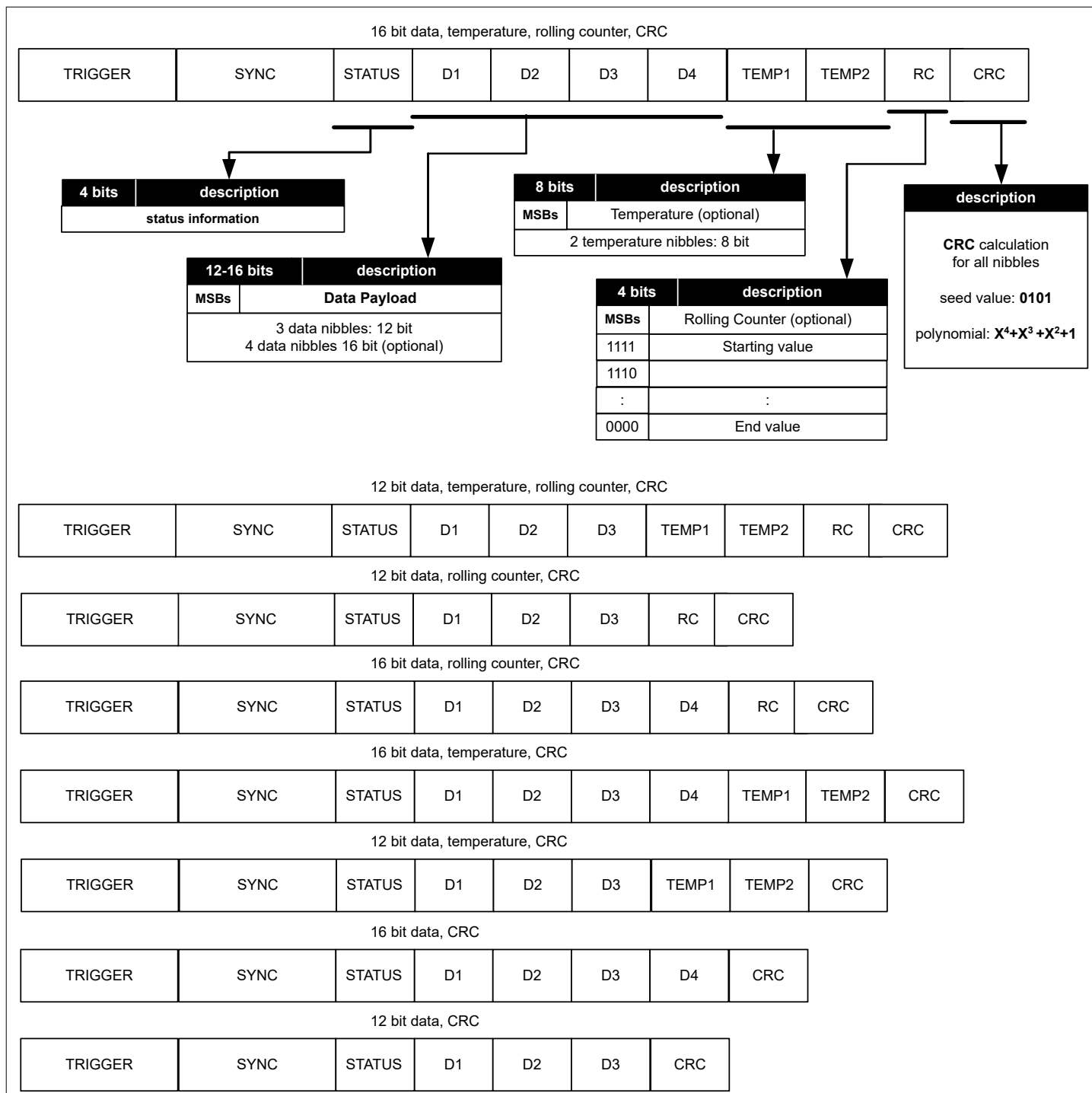

Figure 14 SPC frame modes

Based on the different settings the protocol data content in the nibbles D1 to D4 will be different, in addition to angle value information (as shown above), the user can select to transmit also the angle characteristic curve quadrant information, and or the angle speed information.

The configuration is the same as for the [SENT protocol data](#).

Table 30 SPC Unit Times

Parameter	Symbol	Values			Unit	Note or condition
		Min.	Typ.	Max.		
SPC unit time	UT	0.75	-	3.0	μs	default 3.0μs, configurable steps (0.75, 1, 1.25, 1.5, 2.0, 2.5, 3.0), tolerance given by clock tolerance

5.2.3.1 SPC Bus Mode

When the sensor is used in bus mode with other sensors on a common SPC line, individual addresses have to be assigned to each sensor for identification. For the operation of the sensor in a SPC bus mode, it is strongly recommended that the sensor ID is written into the EEPROM of the sensor, as all sensors are preconfigured with the default value “ID = 0”.

A corresponding trigger nibble from the microcontroller can address each individual sensor. Each trigger nibble low time corresponds to an individual sensor address. The total length of the trigger nibble can be selected to be constant at 90 UT (constant trigger length) or variable (variable trigger length).

5.2.3.2 SPC master trigger pulse

An SPC transmission is initiated by a master trigger pulse on the output pin. To detect a low-level, the voltage must be below the threshold V_{th} . The sensor detects that the output line has been released as soon as V_{th} is crossed. Figure "SPC Master pulse timing" shows the timing definitions for the master pulse. The master low time $t_{m\text{low}}$ is given in table "SPC trigger for bus mode". The total trigger time $t_{m\text{tr}}$ is given in table "SPC master pulse timing".

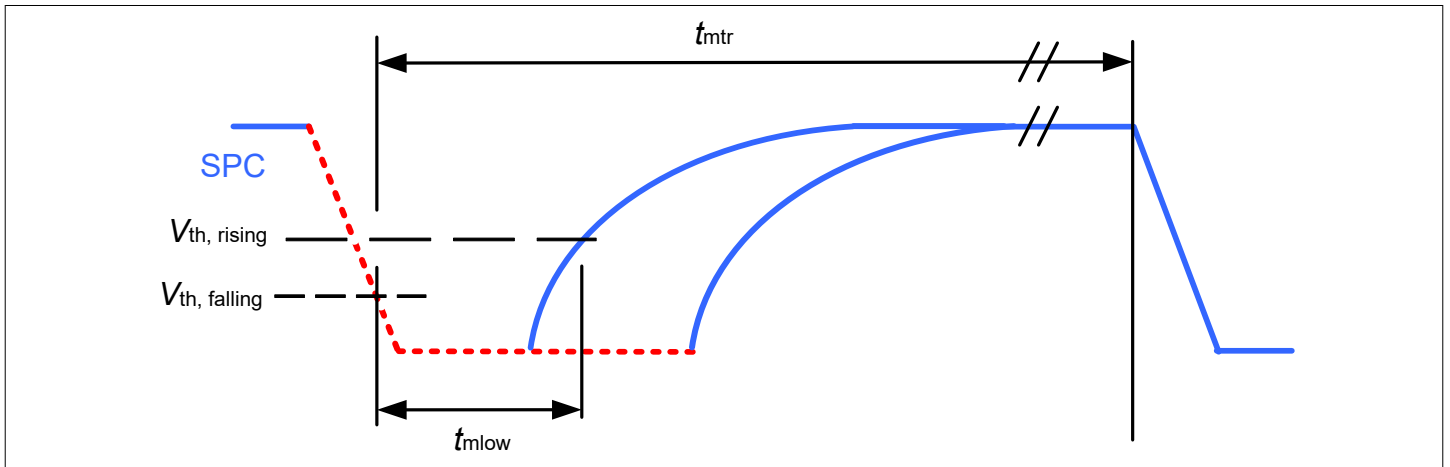

Figure 15 SPC master pulse timing

Table 31 Sensor SPC trigger parameters

Parameter	Symbol	Values			Unit	Note / Test condition
		Min.	Typ.	Max.		
Master nibble low time	$t_{m\text{low}}$	2	-	5	UT	synchronous mode, $UT \geq 1.5\mu\text{s}$
Master nibble low time	$t_{m\text{low}}$	2	-	7	UT	synchronous mode, $UT \leq 1.25\mu\text{s}$

(table continues...)

Table 31 (continued) Sensor SPC trigger parameters

Parameter	Symbol	Values			Unit	Note / Test condition
		Min.	Typ.	Max.		
Master nibble low time	$t_{m\text{low}}$	8	-	15	UT	addr. 0
Master nibble low time	$t_{m\text{low}}$	16	-	28	UT	addr. 1
Master nibble low time	$t_{m\text{low}}$	29	-	49	UT	addr. 2
Master nibble low time	$t_{m\text{low}}$	50	-	82	UT	addr. 3

Table 32 SPC master pulse parameters

Parameter	Symbol	Values			Unit	Note or condition
		Min.	Typ.	Max.		
Threshold, falling edge	$V_{\text{th_falling}}$	-	35	-	% of VDD	
Threshold, rising edge	$V_{\text{th_rising}}$	-	50	-	% of VDD	not subject to production test - verified by design/characterization
Total trigger time	t_{mtr}	-	90	-	UT	for constant trigger length
Total trigger time	t_{mtr}	-	$t_{m\text{low}} + 12$	-	UT	trigger time in the sensor is fixed to the number of units specified in the "typ." column, but the effective trigger time varies due to the sensor's clock variation for variable trigger length

5.2.3.3 SPC Features

SPC Status Nibble

The status nibble, which is sent with each SPC data frame, provides an error indication. In case the sensor detects an error, the corresponding error bit in the status nibble is set. An error is indicated by the corresponding error bit in the status nibble as long as it persists, but at least once.

Table 33 Structure of SPC status nibble

Bits	Description
[0] LSB	Short Serial Message bit (data) or bus mode ID LSB
[1]	Short Serial Message bit (start indication) or bus mode ID MSB
[2]	Warning bit (e.g. air gap warning or OV/UV indication)
[3] MSB	Error indication or sensor reset

Note: For more information about the warning bit and the error indication bit please consult the TLE49SR user manual.

Checksum nibble details

The checksum nibble is a 4-bit CRC of the data nibbles. Optionally the status nibble can be included by register setting. The CRC is calculated using a polynomial $x^4 + x^3 + x^2 + 1$ with a seed value of 0101B. The remainder after the last data nibble is transmitted as CRC.

Short serial message

The short serial message is an additional option which can be enabled and disabled. The short serial message provides additional information in the status nibble by transmitting an 8 bit temperature value, and a 52 bit user and sensor ID.

1 short serial message will be constructed out of 16 SPC frames. In each SPC frame, one bit of information is transmitted in bit [0] of the status nibble and has following structure:

- 4 bit message ID
- 8 bit data
- 4 bit CRC (calculated from message ID and data bits)

The start of the short serial message is indicated by a “1” in bit [1] of the status nibble. For the next 15 frames, this bit will contain a “0”.

The message ID is used for identification of the type of data received. All data are transmitted in the bit [0] of the status nibble in the order MSB to LSB

Rolling counter

The rolling counter counts the number of transmitted frames with rollover back to 0 and increment with each message. This counter is for verification in the ECU that no frame is missed or that no frame is sent repeatedly from the sensor.

Temperature information

Same format as in the SENT chapter, see Temperature information in the [SENT Features](#) chapter.

SPC frameholder

The SPC frameholder enables multiple sensors on the bus to synchronously measure the sensor value. Without frameholder function, the sensor sends its response immediately after the trigger pulse when the sensor ID and the

trigger ID are the same. In case the frameholder function is activated all sensors on the bus start an angle measurement after the trigger pulse and store the measurement result in the memory. Only the addressed sensor replies immediately after the trigger on the bus is received. All other sensors will respond when the corresponding sensor ID is polled by a separate trigger pulse.

5.2.4 SICI programming interface

A single wire interface (SICI) which is on the same output pin as the PWM, SENT/SPC output, is implemented. This interface is used to perform the EEPROM programming with application and customer specific data (angle base, look-up table, customer-ID). In addition, some chip configuration can be done. More details can be found in the corresponding user manual.

5.3 Programming characteristics

Sensor ID

The sensor has an electrically stored ID which allows unique tracking after production.

Customer ID

Customer specific data, e.g. customer module ID, can be written in the EEPROM via SICI interface.

SICI programming SPC

The sensor can be programmed in a configuration of up to 4 bus participants on the same SPC bus line and the same supply. The sensor output pin is tristate, if it was not addressed for communication.

5.3.1 Calibration and Look-Up-Table (LUT)

The sensor allows configuration of 32 equidistant calibration points or 16 freely programmable calibration points, as shown at the below figures:

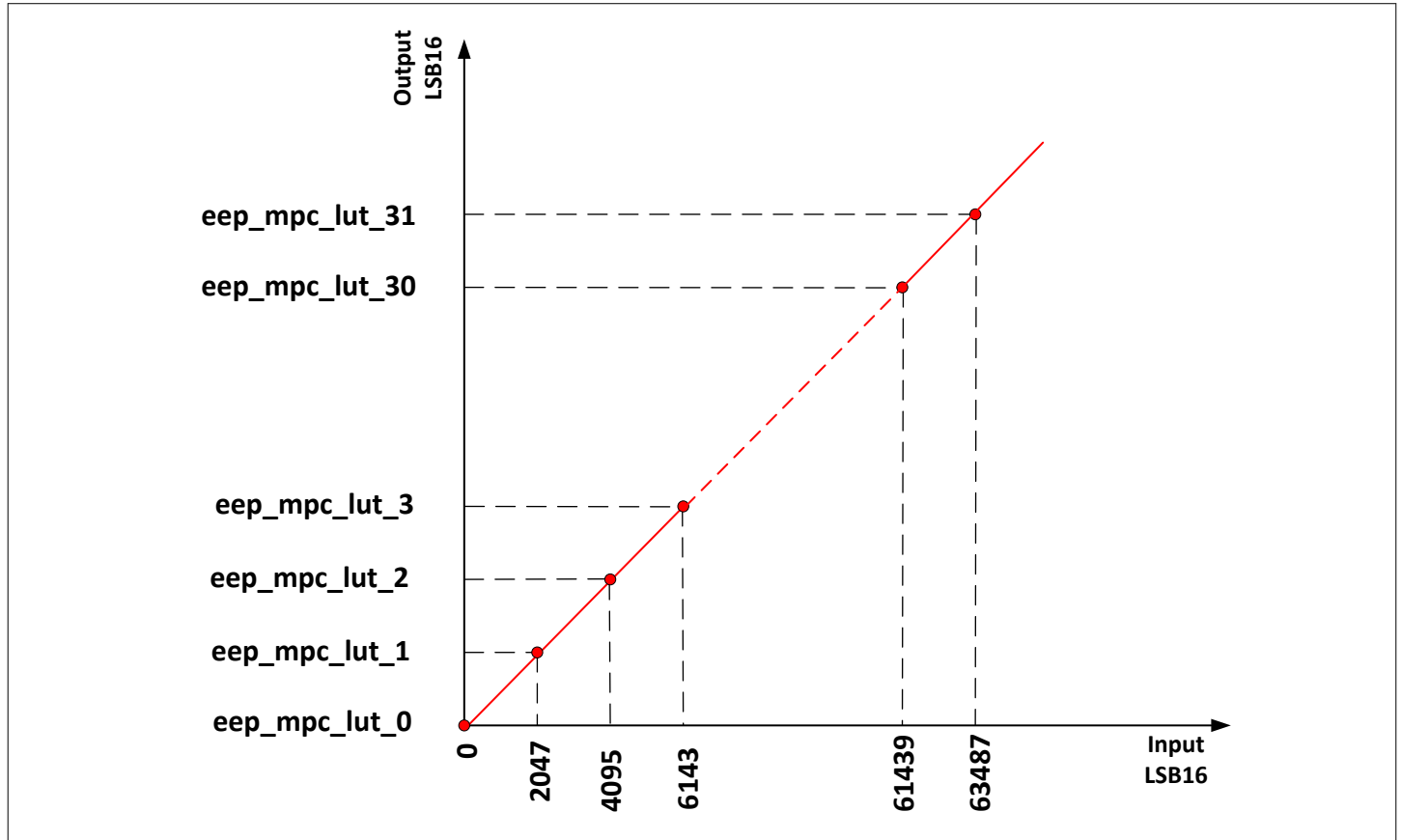

Figure 16 32 equidistant calibration points

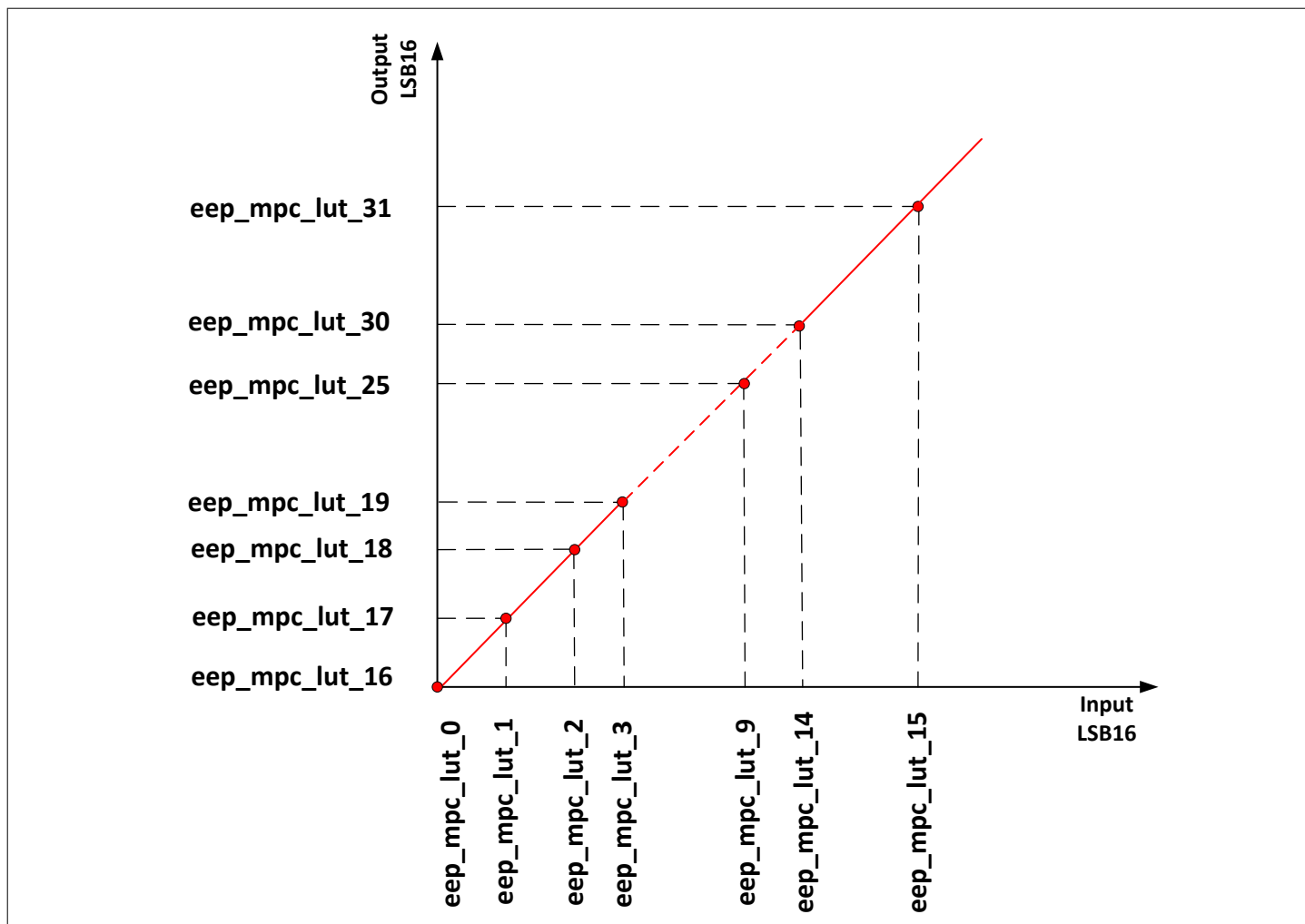

Figure 17 16 freely programmable points

5.3.2 Programmable measurement range

Free selective measuring range

The measuring range (start / stop) is freely selective with a resolution of 14 bit. The resolution of 14 bit refers to 360°. The characteristic curve of the sensor can be divided up to 4 predefined segments. Typically, the 360° angular range is divided into 4 x 90°, 3 x 120° or 1 x 360° segments.

Additionally, it is possible to define a measurement range inside the full 360° range. For example, a 70° measurement range can be defined from 40° to 110°.

It is also possible to clamp the angle limits, this can be freely configured by the customer, plus the calibration points can be used to linearize the characteristic curves.

Please note that the calibration points are always for 360°, so at least 1 or 2 points have to be sacrificed to complete the 360° if the angle range is clamped.

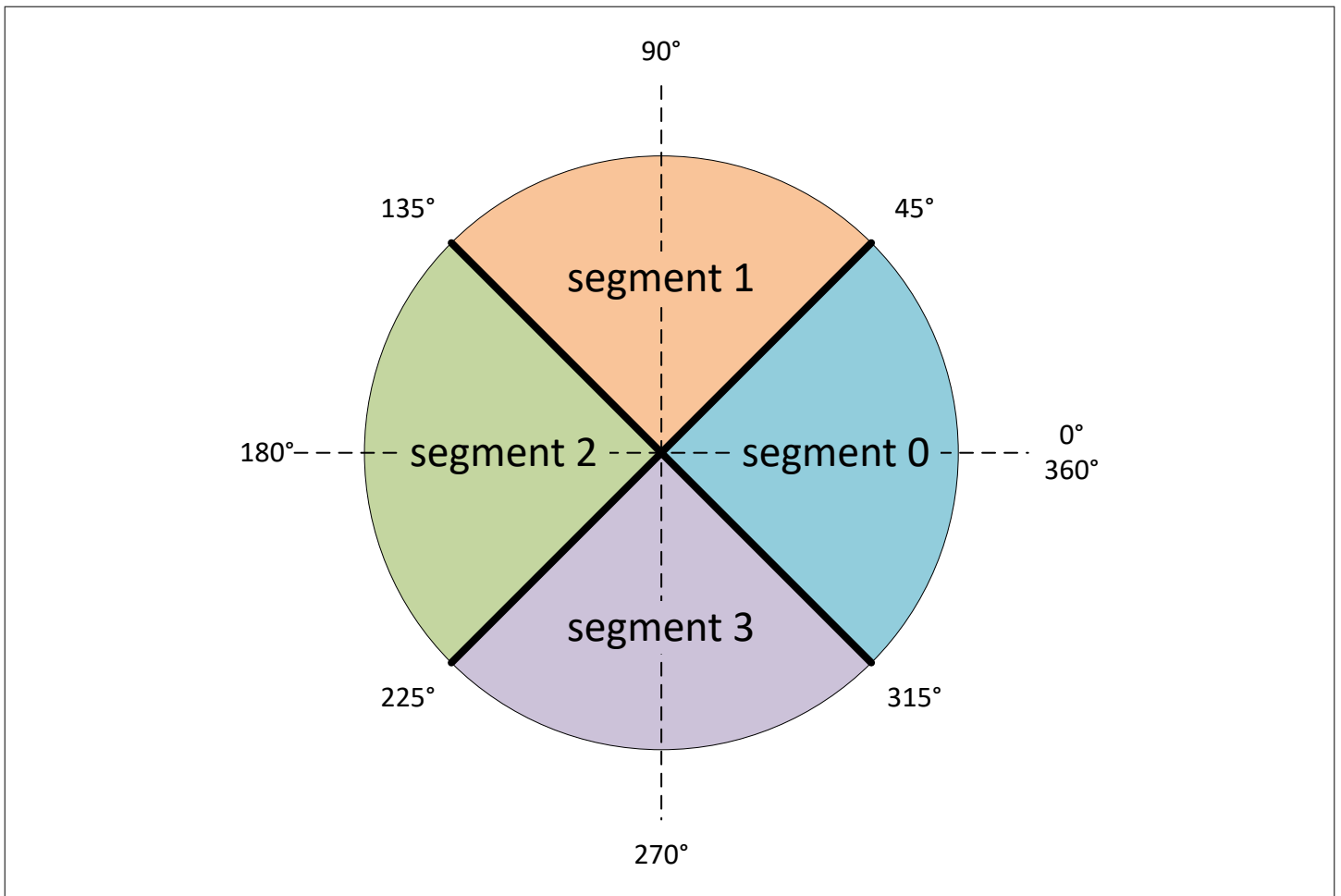

Figure 18 Programmable output 90° characteristic curve

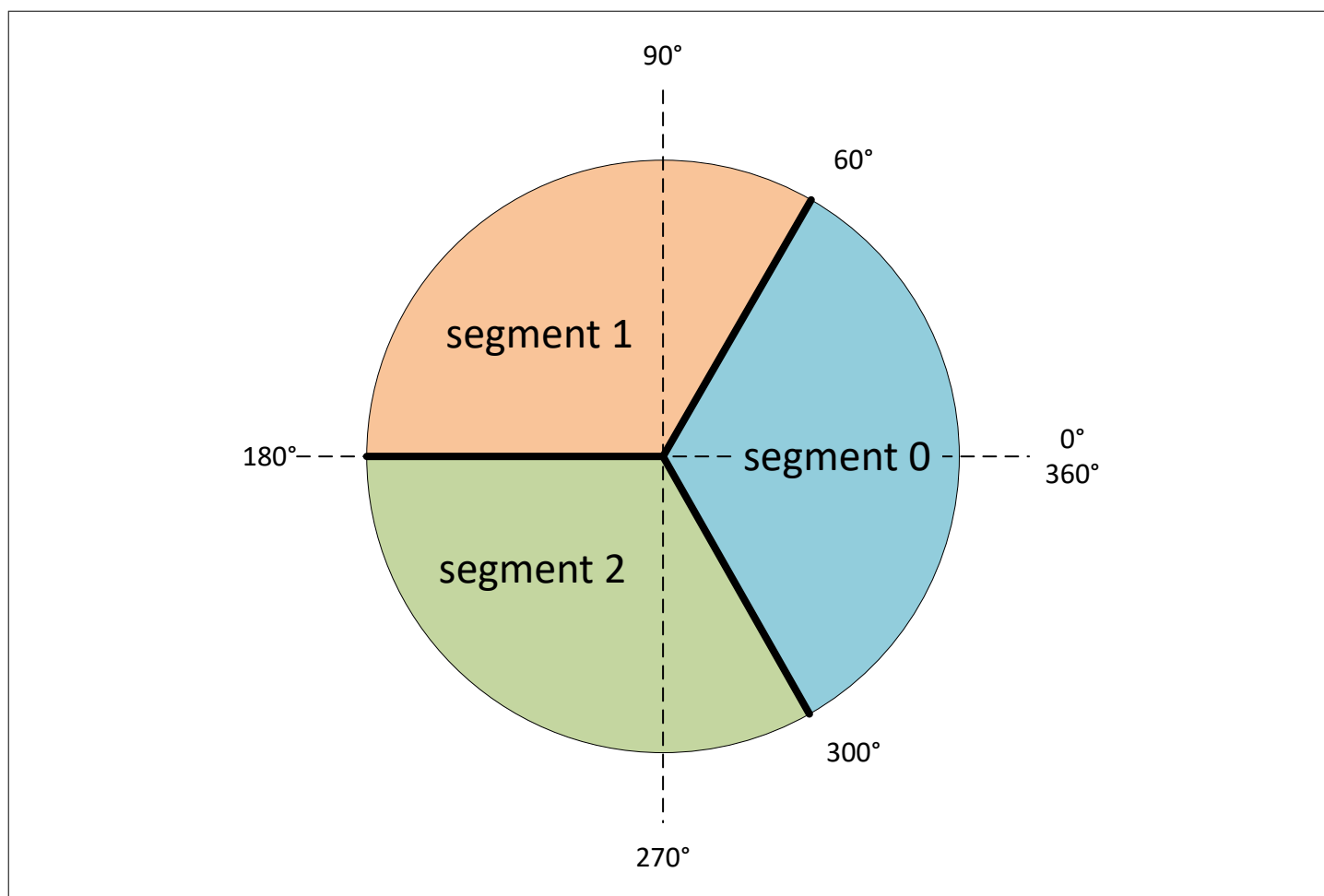

Figure 19 Programmable output 120° characteristic curve

5.3.3 EEPROM

The sensor includes a non-volatile memory (NVM) where calibration data and sensor configuration data are stored. The customer has access to a part of this memory for storage of application specific data (e.g. look-up table & customer ID)

Table 34 EEPROM parameters

Parameter	Symbol	Values			Unit	Note or condition
		Min.	Typ.	Max.		
Number of possible NVM programming cycles	n_{Prog}	-	-	100	-	-
Time for programming of whole NVM (customer relevant part)	t_{Prog}	-	0.5	-	s	incl. look-up table, configuration, customer ID
Programming temperature	$T_{\text{prog_temp}}$	10	-	60	°C	

6 Application Information

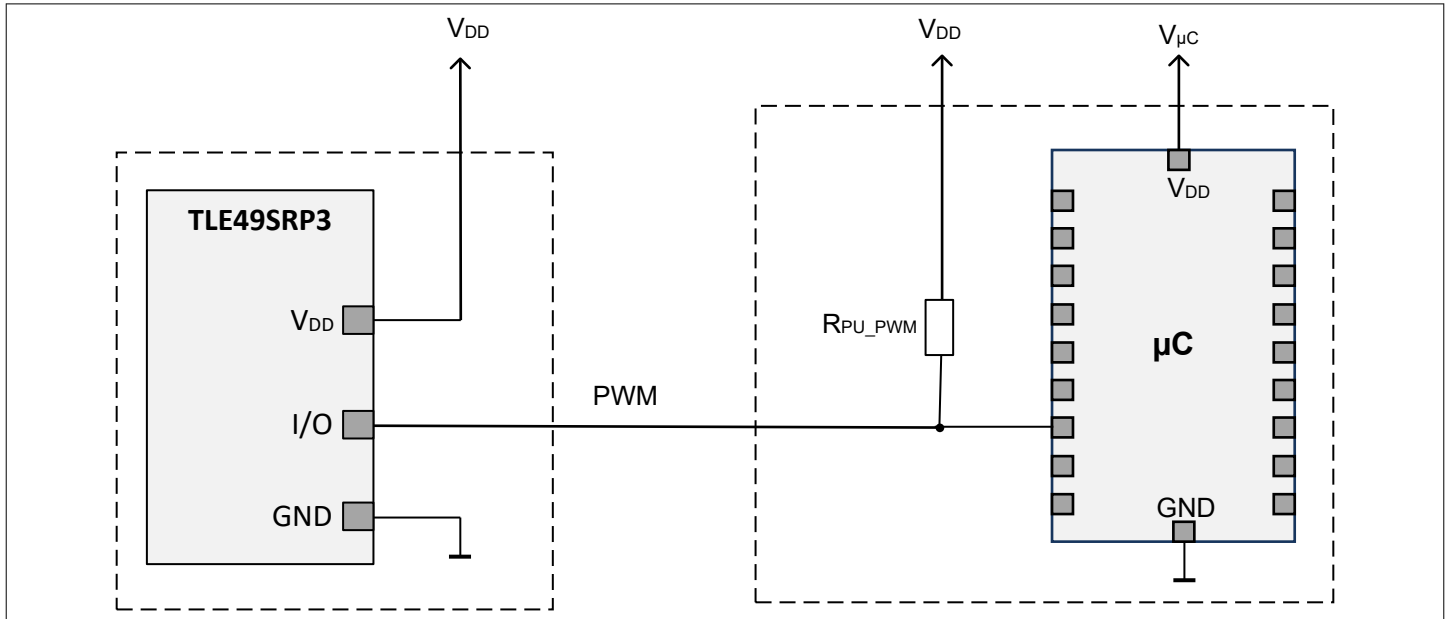

Figure 20 Application Circuit for PWM interface (falling edge start)

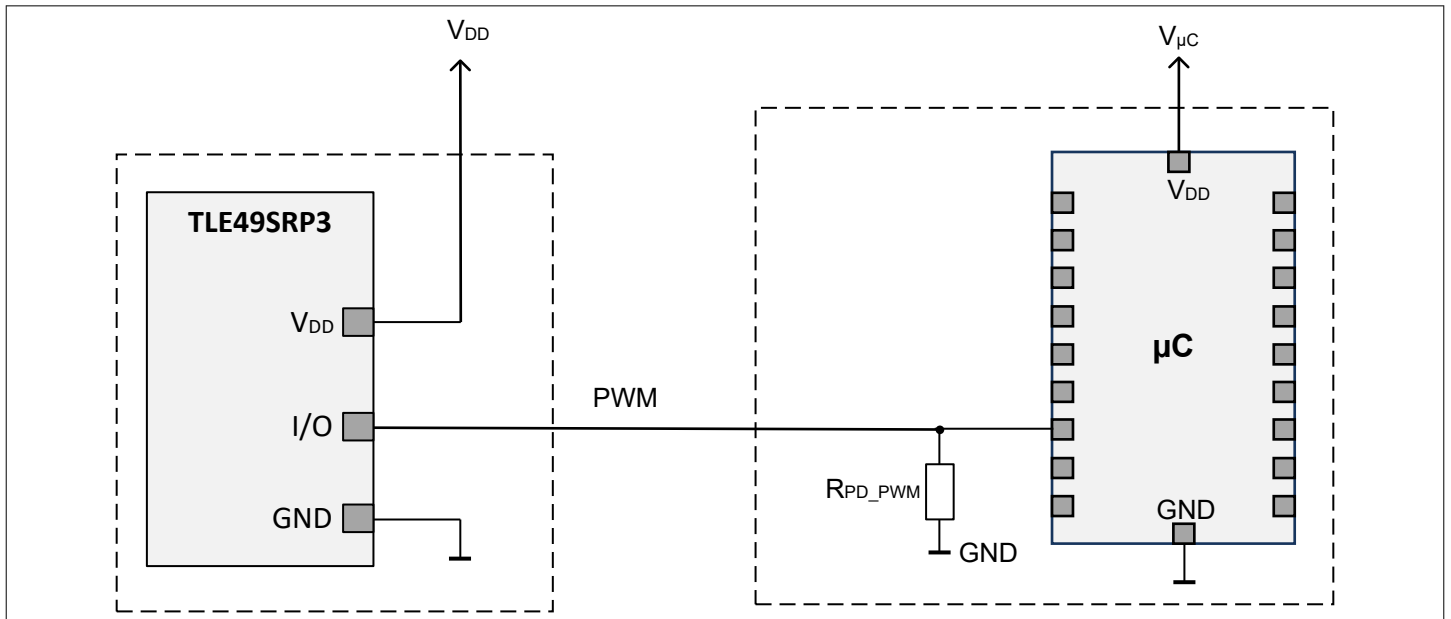

Figure 21 Application Circuit for PWM interface (rising edge start)

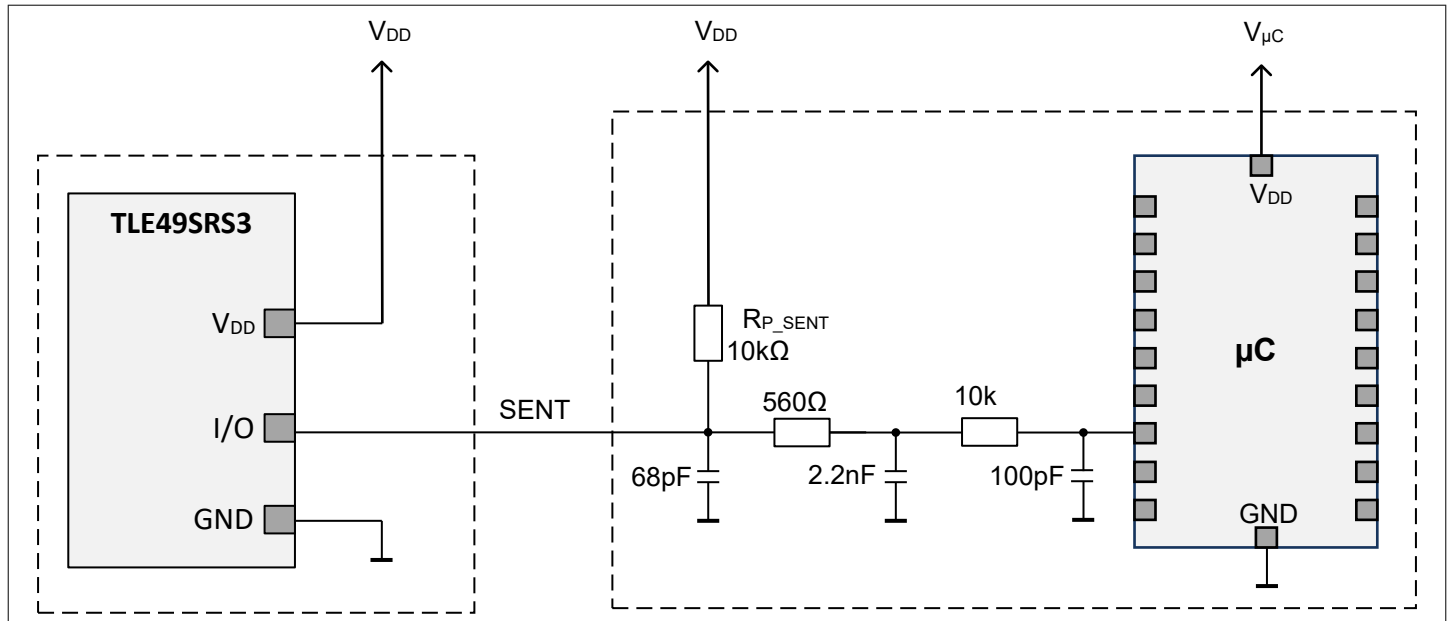

Figure 22 Application Circuit for SENT interface

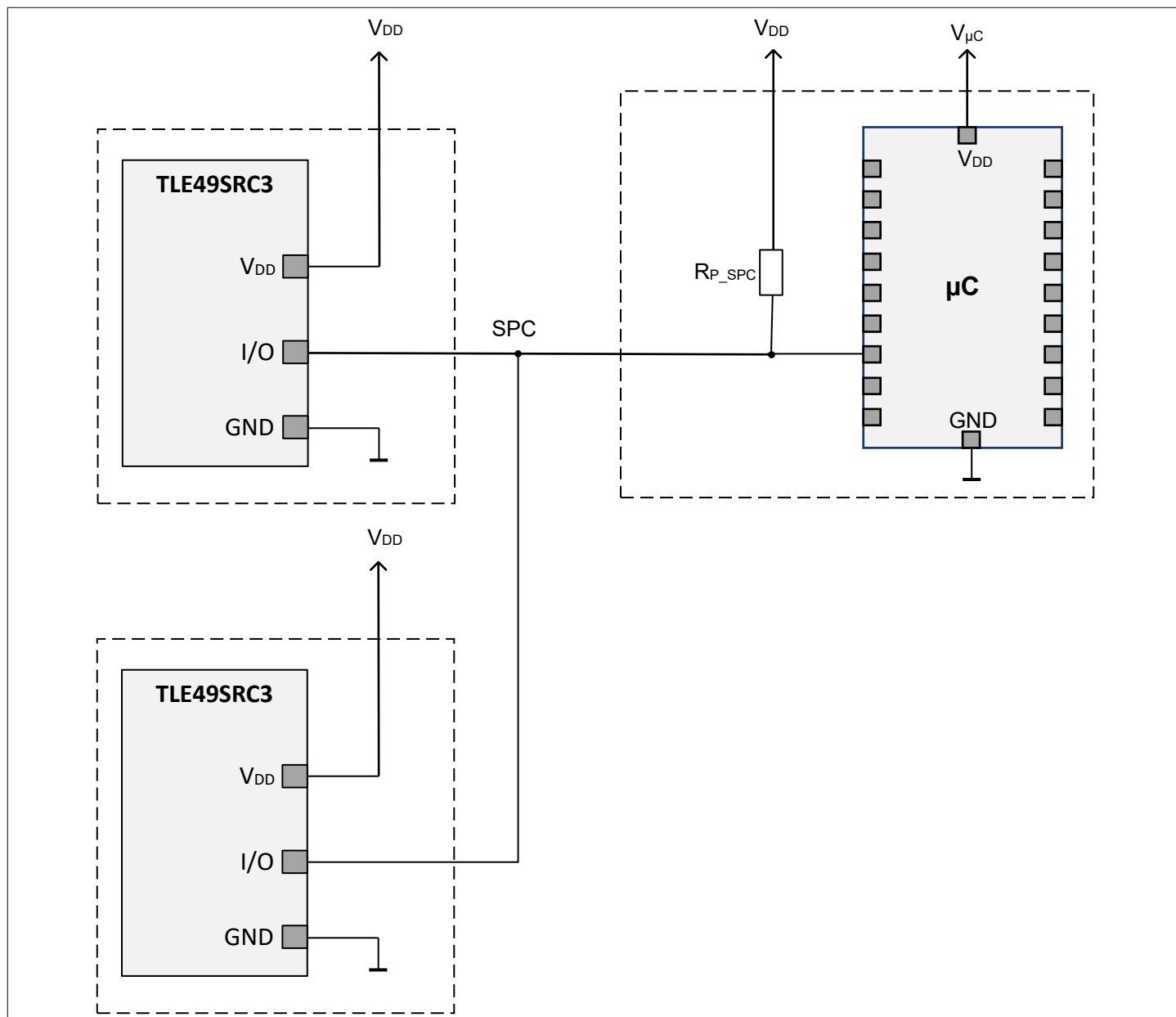

Figure 23 Application Circuit for SPC bus interface

7 Package information

The device is is halogen free, lead free and RoHS compliant.

Table 35 Position tolerances die to package

Parameter	Symbol	Values			Unit	Note / Test condition
		Min.	Typ.	Max.		
Tilt	-	-	-	2	°	in respect to the z-axis and reference plane
Rotational displacement	-	-	-	3	°	in respect to the reference axis
Placement tolerance in package	-	-	-	100	µm	in x and y direction

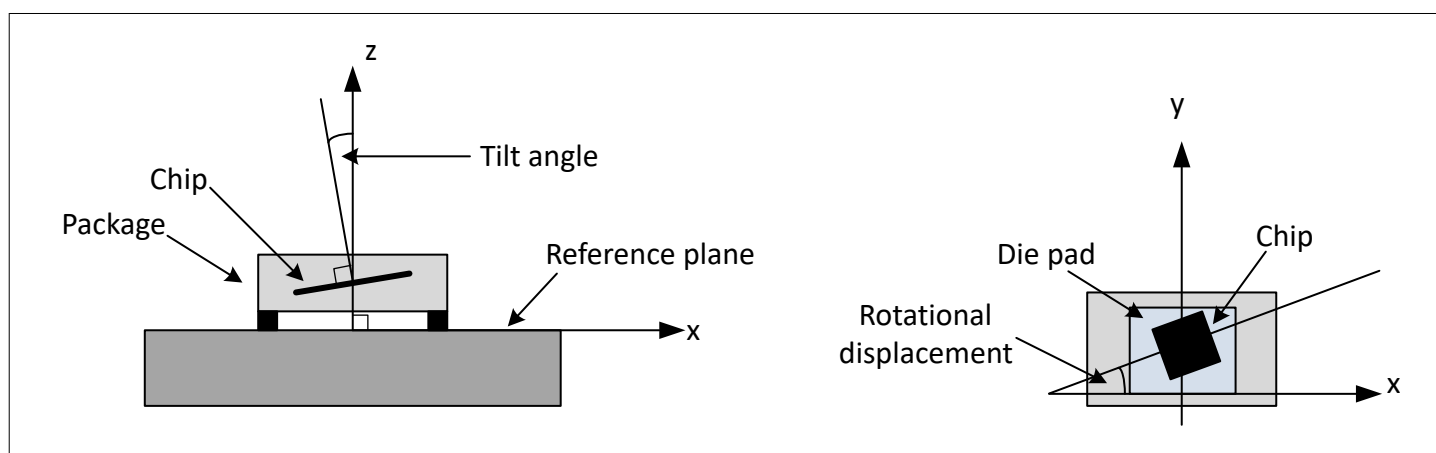

Figure 24 Tolerance of the die in the package

The package type is PG-SSO-3-41

TLE49SR
Stray field robust angle sensor with PWM/SENT/SPC interface



7 Package information

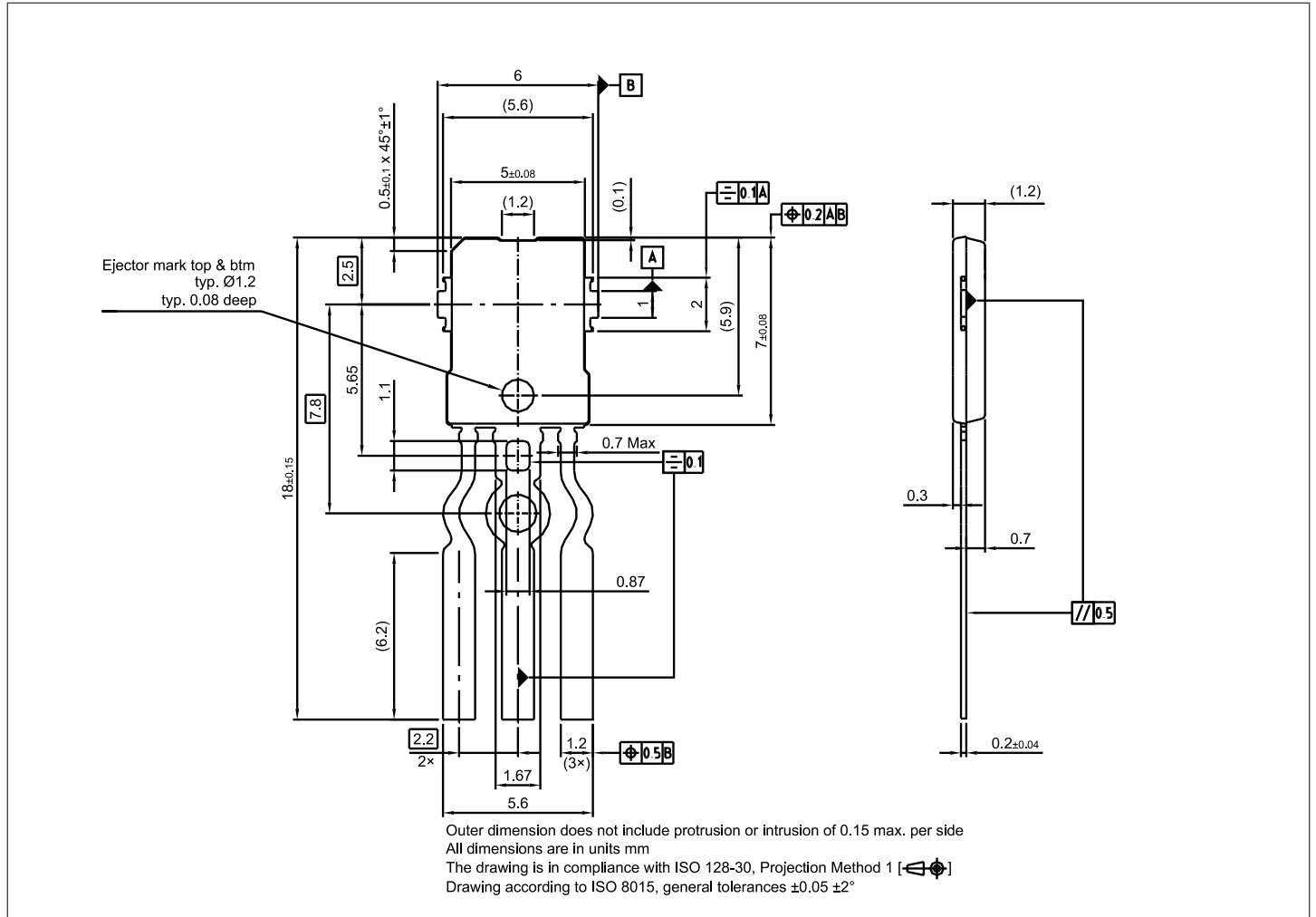

Figure 25 PG-SSO-3-41 package drawing

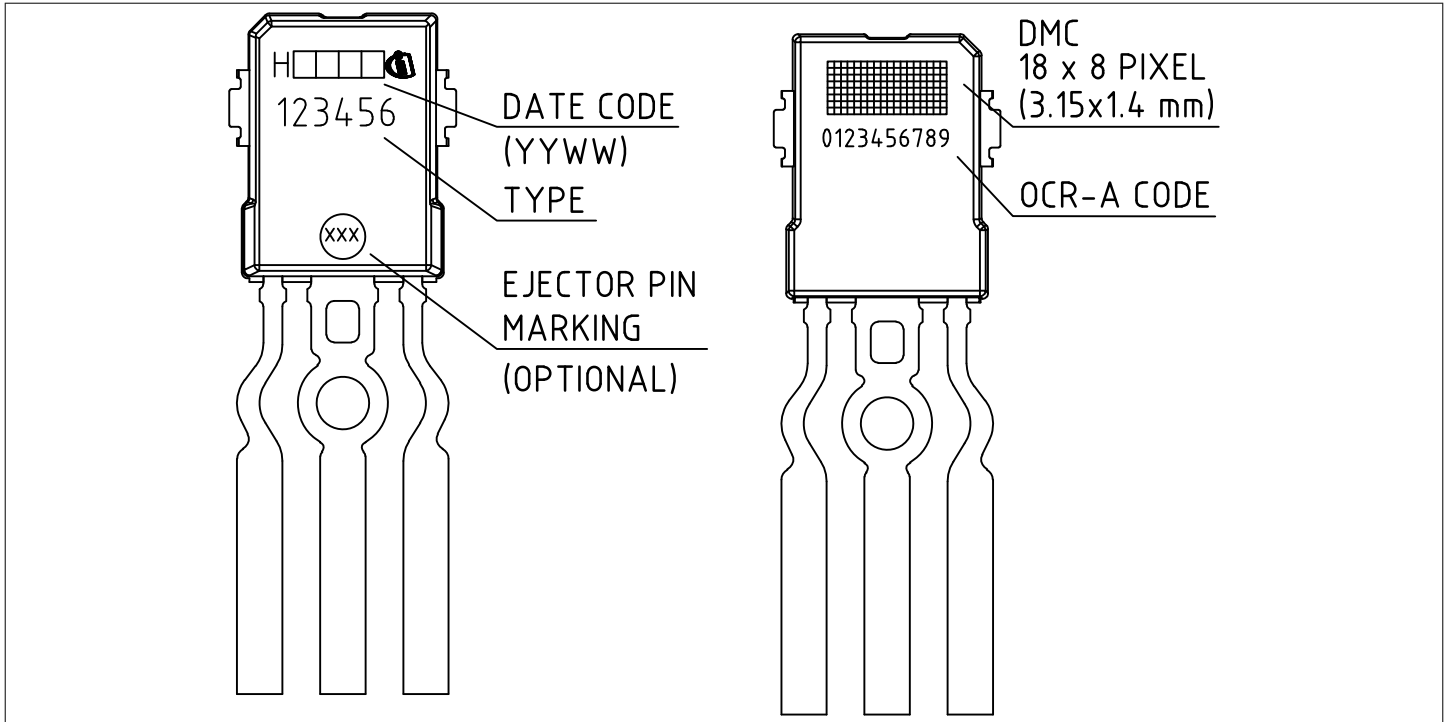

Figure 26 PG-SSO-3-41 Marking specification

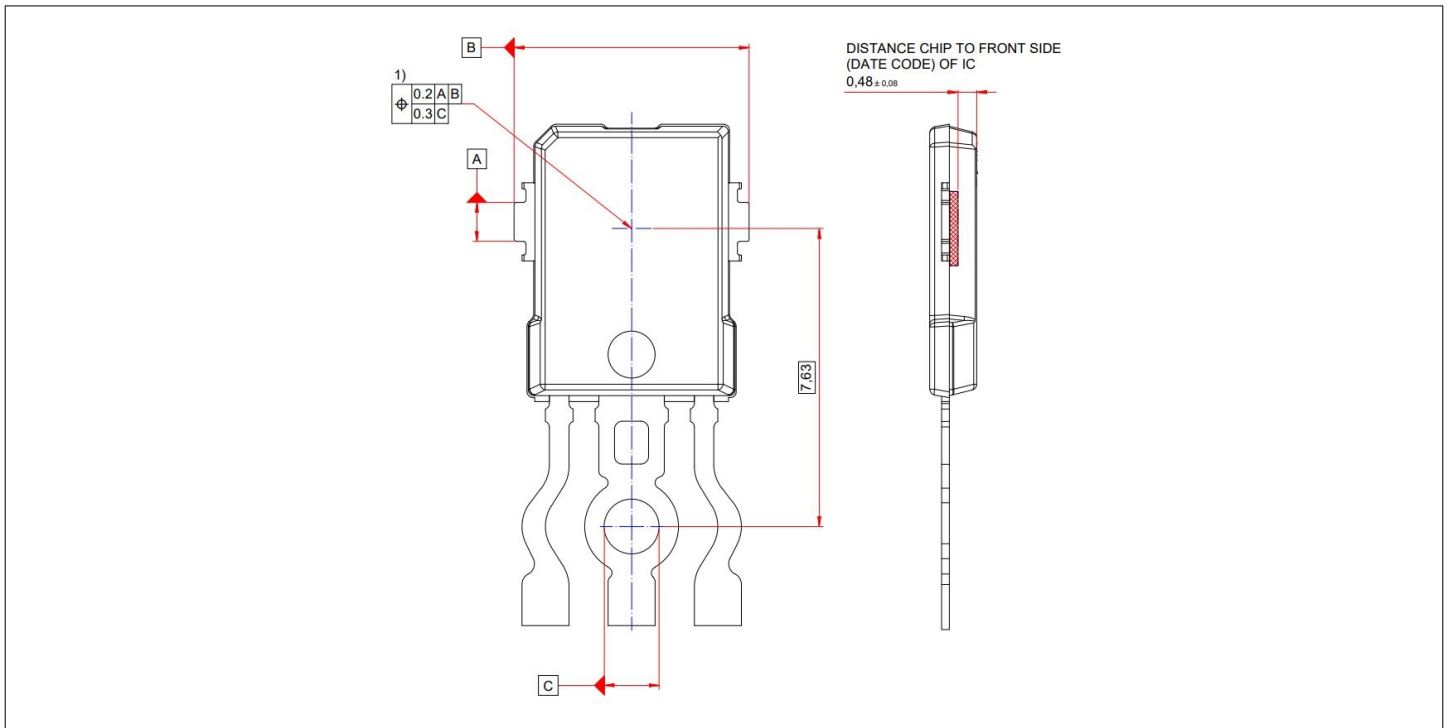

Figure 27 PG-SSO-3-41 Center of sensitive area

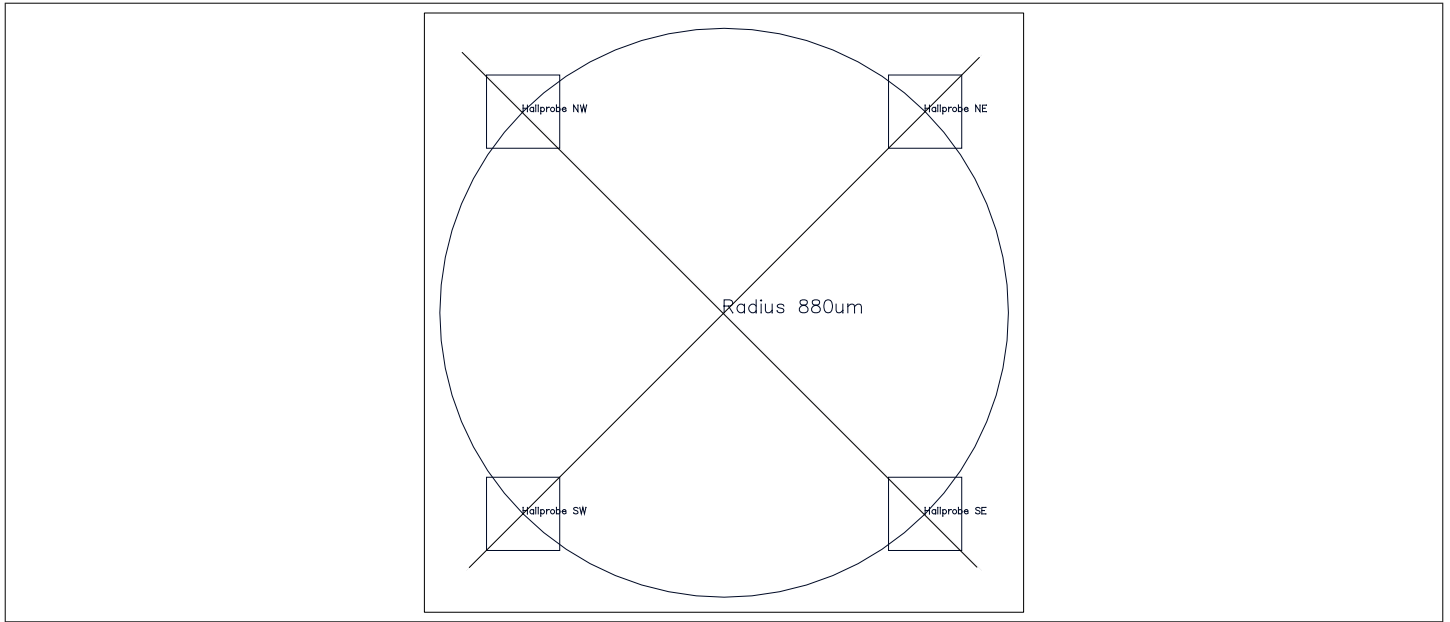

Figure 28 TLE49SR Hall element radius

8 Revision history

Revision	Date	Change description
Rev. 1.00	2024-03-13	Initial release

Trademarks

All referenced product or service names and trademarks are the property of their respective owners.

Edition 2024-03-13

Published by

Infineon Technologies AG

81726 Munich, Germany

© 2024 Infineon Technologies AG

All Rights Reserved.

Do you have a question about any aspect of this document?

Email: erratum@infineon.com

Document reference

IFX-wup1581414051189

Important notice

The information given in this document shall in no event be regarded as a guarantee of conditions or characteristics ("Beschaffheitsgarantie").

With respect to any examples, hints or any typical values stated herein and/or any information regarding the application of the product, Infineon Technologies hereby disclaims any and all warranties and liabilities of any kind, including without limitation warranties of non-infringement of intellectual property rights of any third party.

In addition, any information given in this document is subject to customer's compliance with its obligations stated in this document and any applicable legal requirements, norms and standards concerning customer's products and any use of the product of Infineon Technologies in customer's applications.

The data contained in this document is exclusively intended for technically trained staff. It is the responsibility of customer's technical departments to evaluate the suitability of the product for the intended application and the completeness of the product information given in this document with respect to such application.

Warnings

Due to technical requirements products may contain dangerous substances. For information on the types in question please contact your nearest Infineon Technologies office.

Except as otherwise explicitly approved by Infineon Technologies in a written document signed by authorized representatives of Infineon Technologies, Infineon Technologies' products may not be used in any applications where a failure of the product or any consequences of the use thereof can reasonably be expected to result in personal injury.