

Arm® Cortex®-M33 32-bit MCU+FPU+DSP, 180 MHz, up to 256 KB Flash/64 KB SRAM, Real-time Control

Features

- High-performance, low-power 32-bit single-core Arm® Cortex® M33-based microcontroller with digital signal processor (DSP), floating-point unit (FPU), and state-of-the-art security features
- High-performance, programmable analog subsystem (HPPASS):
 - 12-bit, 12-Msps SAR ADC with parallel idle sampling of up to 16 analog channels
 - Five comparators with <10 ns built-in 10-bit DAC and slope generator
- Real-time control peripherals:
 - Coordinate rotation digital computer (CORDIC)
 - 16 x 16-bit and 4 x 32 bit timer/counter pulse-width modulator (TCPWM) supporting <80 ps high-resolution pulse-width modulator (HRPWM)
- Enhanced routing flexibility with a combinatorial trigger multiplexing unit
- Communication interfaces: Up to six SCB and two CAN FD (one supporting 8 Mbps)
- 256 KB read-while-write flash with ECC support
- Low-power operation modes down to 300 nA: Sleep, Deep Sleep (three modes) and Hibernate
- Up to 50 GPIOs with programmable drive modes, strengths, and slew rates; up to 28 pins support Smart I/O programmable logic and up to 16 dedicated analog pins
- Security: PSA L2 certified; configurable flash partitioning and protection
- Safety: Class B and SIL 2 compliant safety test libraries are available
- Power supply range: 1.71 V to 3.6 V
- Ambient temperature range: -40°C to 105°C Ta
- Packages: VQFN-48, E-LQFP-48, VQFN-64, E-LQFP-64, E-LQFP-80



Green



Halogen-free



Lead-free

Potential applications

- Motor control in power tools, home appliances, industrial drives, light electric vehicles, robotics, and drones
- Digital power control in switched mode power supply (SMPS) and PFC applications for LED lighting, EV chargers, solar inverters, servers, and PC power supplies
- Wide bandgap technologies (e.g., SiC and GaN) based motor control and power conversion applications

Description

The PSC3P5xD and PSC3M5xD devices are based on the Arm® Cortex®-M33 running up to 180 MHz with DSP and FPU capability. In addition to the CPU subsystem, the devices contain advanced real-time control peripherals, such as high-performance programmable analog subsystem, comparators, advanced timers with high-resolution capability, up to six SCBs and two CAN FDs for communication. The devices support one Active and five low-power modes for managing and reducing the power consumption depending on application requirements.

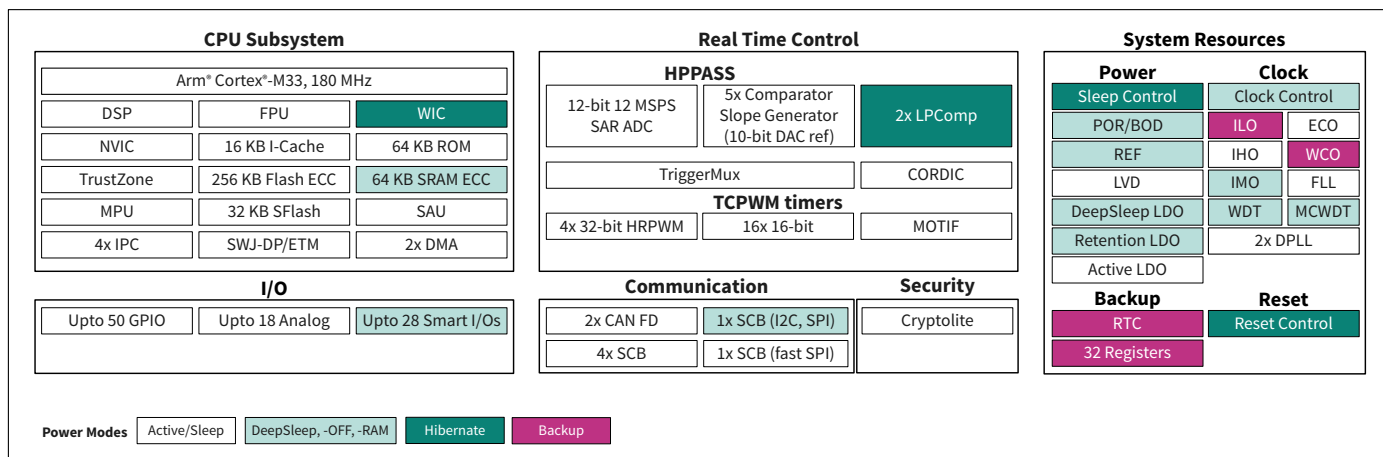

Table of contents

	Features	1
	Potential applications	1
	Description	1
	Table of contents	2
1	Introduction	5
2	Detailed features	7
3	Chip-level functional description	10
3.1	Power	10
3.1.1	Power connections	10
3.1.2	Power domains	12
3.1.3	Power modes	13
3.1.4	Power mode transitions	14
3.1.5	Power block support	14
3.2	Security	15
3.2.1	Security features	15
3.2.2	Security architecture overview	16
4	Block functional description	17
4.1	CPU	17
4.2	DMA	17
4.3	Cryptography support (CryptoLite)	17
4.4	Memory	17
4.4.1	Flash	17
4.4.2	SFlash	18
4.4.3	ROM	18
4.4.4	RAM	18
4.5	eFuse	18
4.6	Clock system	18
4.6.1	Internal main oscillator (IMO)	19
4.6.2	Internal high-frequency oscillator (IHO)	19
4.6.3	Internal low-frequency oscillator (ILO)	19
4.6.4	External crystal oscillator (ECO)	19
4.6.5	Watch crystal oscillator (WCO)	19
4.6.6	Watchdog timer (WDT)	19
4.6.7	Real-time clock (RTC)	19
4.7	Reset	20
4.8	High-performance programmable analog subsystem (HPPASS)	20
4.8.1	12-bit SAR analog-to-digital converter (ADC)	20

Table of contents

4.8.2	Comparator and slope generator (CSG)	20
4.8.3	Temperature sensor	21
4.9	Low-power comparator (LPComp)	21
4.10	Fixed function digital	21
4.10.1	Timer/counter pulse-width modulator (TCPWM)	21
4.10.2	Serial communication block (SCB)	21
4.10.2.1	Inter-integrated circuit (I2C)	21
4.10.2.2	Universal asynchronous transmitter receiver (UART)	22
4.10.2.3	Serial peripheral interface (SPI)	22
4.10.3	Controller area network flexible data-rate (CAN FD)	22
4.11	Trigger multiplexer (Trigger MUX)	22
4.12	Coordinate rotation digital computer (CORDIC)	22
4.13	General-purpose input/output (GPIO) ports	22
4.14	Smart I/O (Programmable I/O)	23
4.15	Device firmware update (DFU)	24
4.16	Serial wire JTAG debug port/Embedded trace macrocell	25
5	Pins	26
6	GPIO alternate functions tables	31
7	Electrical specifications	42
7.1	Absolute maximum ratings	42
7.2	Device level specifications	42
7.2.1	Power supplies	42
7.2.2	CPU currents and transition times	44
7.2.3	XRES	46
7.2.4	GPIO	46
7.3	Analog peripherals	48
7.3.1	LP comparator	48
7.3.2	HPPASS	49
7.4	Digital peripherals	55
7.4.1	HRPWM specification	55
7.4.2	TCPWM specifications	55
7.4.3	SCB	56
7.5	Memory	60
7.6	System Resource	61
7.6.1	Power-on reset (POR)	61
7.6.2	Voltage monitors	61
7.6.3	Single Wire Debug (SWD) and Trace Interface	62
7.6.4	Internal oscillator crystal oscillator and external clock specifications	62
7.7	Smart I/O	65
7.8	JTAG boundary scan specifications	65
8	Ordering information	68

Table of contents

8.1	Part number nomenclature	69
9	Package information	71
10	Errata	78
11	Acronyms	83
12	Document conventions	85
12.1	Units of measure	85
	Revision history	86
	Disclaimer	88

1 Introduction

The PSC3P5xD and PSC3M5xD devices are part of the PSOC™ Control C3 MCU family designed for real-time control, enhanced sensing, secure, and low-power operations. Some target applications for these microcontrollers are:

- Industrial motor-controllers
- Power-stage converters
- Home appliances
- Automation devices
- Low-power sensors

A detailed block diagram of the MCU is shown in [Figure 1](#).

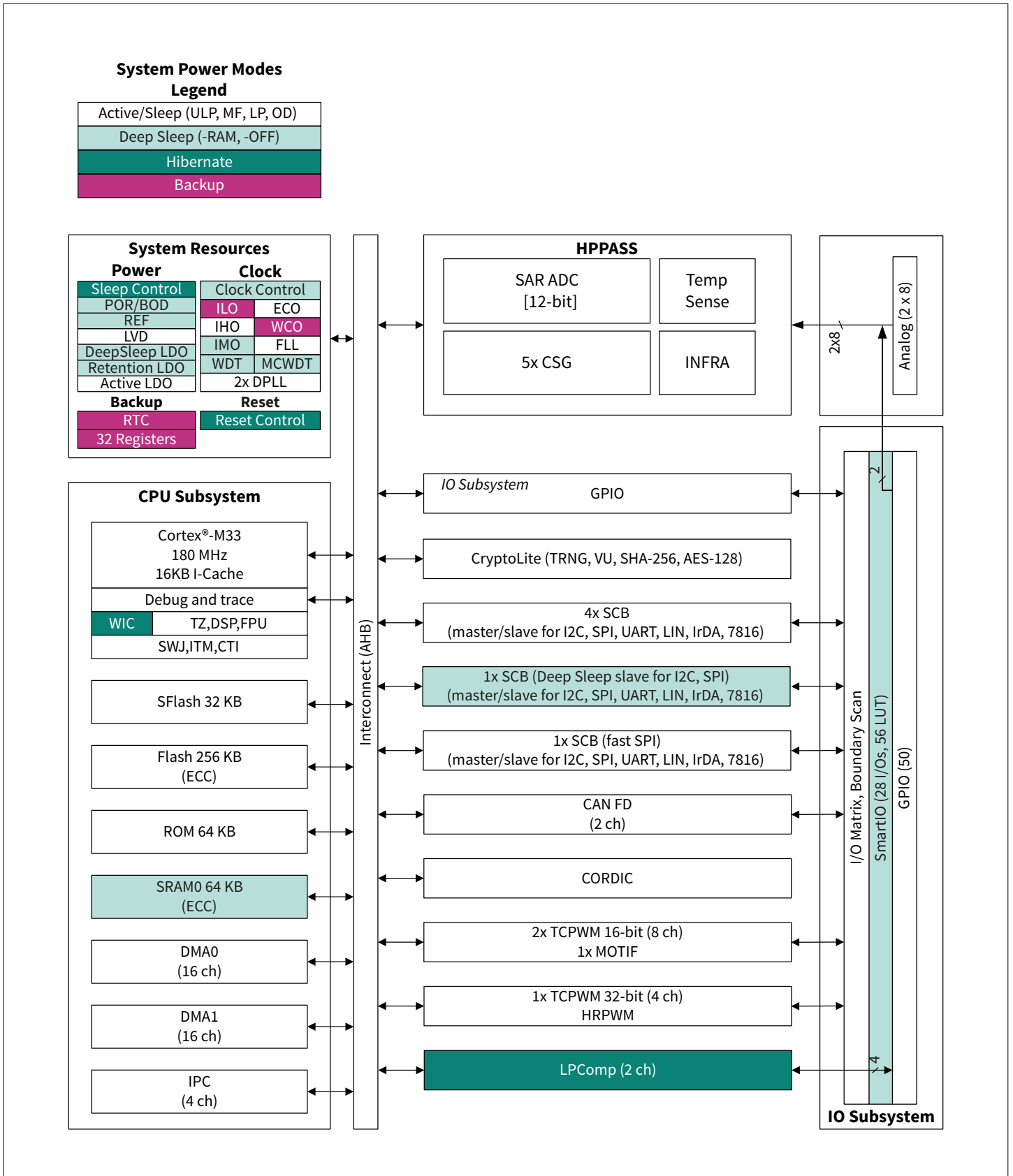

Figure 1 Functional block diagram

Device identification and revisions

Family ID = 0x118(12-bit); Si ID range = EE40- EE7F; Major-minor rev ID = 0x1, 0x1

2 Detailed features

This device has the following features:

- CPU subsystem
 - Arm® Cortex®-M33 running up to 180 MHz
 - Digital signal processor (DSP), floating-point unit (FPU), memory protection unit (MPU), 16 KB I-cache
 - Two direct memory access (DMA) controllers with 16 channels each
 - Security
 - Platform security architecture level 2 (PSA L2) certified
 - Step-wise authentication of execution images until the control is handed over to the user code
 - Secure execution of code in the execute-only mode for protected routines
 - Image authentication and integrity check
 - TrustZone framework that establishes an isolated device root of trust (RoT) for trust attestation and software management
- Memory
 - On-chip flash with ECC support
 - Up to 256-KB flash with read while write (RWW) capability, 64 KB ROM for boot code, and bootloader functions
 - Built-in device firmware upgrade (DFU) support in boot ROM via serial interface (UART/I2C/SPI)
 - SRAM with ECC support
 - 64 KB full SRAM available in Deep Sleep
 - SRAM data path is protected with a hardware mechanism (ECC) for soft error detection and correction
- Clocking subsystem
 - 8 MHz IMO with Deep Sleep operation offering $\pm 2\%$ accuracy
 - 48 MHz internal high-frequency oscillator (IHO) offering $\pm 1\%$ accuracy
 - 32 kHz internal low frequency oscillator (ILO) offering $\pm 10\%$ accuracy
 - 4 to 35 MHz external crystal oscillator (ECO) support
 - 32.768 kHz external watch crystal oscillator (WCO) usable for real-time clock (RTC)
 - External clock (EXTCLK): Maximum frequency 80 MHz
 - One frequency lock loop (FLL) with 24-100 MHz output range
 - Two digital phase-locked loops, DPLL#0 and DPLL#1, with 25-250 MHz output range
- Low power (1.71 V to 3.6 V) operation
 - Six power modes (Active, Sleep, Deep Sleep, Deep Sleep-RAM, Deep Sleep-OFF, and Hibernate) for fine-grained power management
 - Deep Sleep mode current of 11 μA at 3.3-V external supply using an internal voltage regulator with 64-KB SRAM retention, LPComp, and Deep Sleep SCB
 - Hibernate mode current with RTC and LPComp of up to 1000 nA
- Communication peripherals
 - Serial communication blocks (SCBs)
 - Up to six independent run-time-reconfigurable SCBs; each is software-configurable as I2C, SPI, or UART in master or slave mode
 - One SCB also supports Deep Sleep operation and wake-up from Deep Sleep in I2C slave and SPI slave modes

2 Detailed features

- One SCB has fast SPI support of up to 50 MHz
- SCB supports single-wire half-duplex mode for UART
- CAN FD
 - Up to two CAN FD channels with a single instance with operation of up to 8 Mbps
- High-performance, programmable analog subsystem (HPPASS)
 - Analog-to-digital converter (ADC)
 - One 12-bit, 12-Msps SAR ADC
 - Up to 16 dedicated analog pads, connected to up to 16 parallel sample stages
 - Two additional GPIOs can be used as analog inputs
 - Up to 16 sample/hold (S/H) circuits in SAR ADC connected to pins directly or through AMUX
 - One S/H circuit in SAR ADC is internally connected to analog references and a temperature sensor
 - Configurable input gain of 1, 3, 6, and 12 on all 16 S/H circuits
 - Digital comparator at the output to compare the ADC result against programmed boundary values
 - Digital comparator outputs can be connected to timer/counter pulse-width modulator (TCPWM) (low latency between the modules)
 - Analog comparators
 - Five Active comparators without Deep Sleep functionality, each with a 10-bit DAC to generate the comparator reference
 - Each comparator supports an external reference/threshold through pins
 - Active comparator can be used with the built-in DAC in Hysteresis mode
 - Two additional comparators in LPComp are available in Active/Deep Sleep/Hibernate modes
 - Comparator outputs can be brought to pins for control loop applications
 - Comparator outputs can be connected to TCPWM (low latency between the modules)
 - Logical OR of multiple comparator trigger outputs connected as an input trigger to TCPWM via trigger MUX
- Real-time control peripherals
 - Coordinate rotation digital computer (CORDIC)
 - Supports all CORDIC operating modes for solving circular (trigonometric), hyperbolic functions, and integrated independent lookup tables to accelerate calculation
 - Timer/counter pulse-width modulator (TCPWM)
 - Sixteen 16-bit TCPWM channels
 - Four 32-bit TCPWM channels supporting high-resolution PWM generation (HRPWM) for PWM outputs
 - Center-aligned, edge, and pseudorandom modes
 - Comparator-based triggering of kill signals
 - Shadow update of duty, period, dead-time, output signal polarity, and dithering (pseudorandom mode)
 - Multichannel control: In a group of eight TCPWM channels, one channel within a group can trigger another channel
 - Ability to logically combine the outputs of multiple channels through Smart I/O
 - Dedicated output triggers mux in a group to allow flexibility to the PWM channel as a trigger and/or gate signals to the HPPASS
 - Hall sensor interface with autonomous BLDC block commutation support
 - Quadrature encoder interface to decode motor speed and rotor position
 - HRPWM feature for period, duty, and dead-time insertion with a typical resolution of less than 80 ps

2 Detailed features

- I/O subsystem
 - Programmable GPIO pins
 - Up to 66 functional pins (50 digital GPIOs; 2 out of 50 GPIOs can be used for analog inputs + 16 dedicated analog-only inputs)
 - Programmable drive modes, strengths, and slew rates
 - Programmable digital
 - Up to seven Smart I/O capable ports (28 I/Os, 56 LUTs) enable Boolean operations on I/O signals
- Cryptography
 - Cryptography accelerator
 - Hardware acceleration for symmetric (AES-128) and asymmetric cryptographic algorithms (RSA and elliptic curve cryptography (ECC)) supported by vector unit (VU) and hash functions (SHA-256)
 - True random number generator (TRNG) function

3 Chip-level functional description

3.1 Power

The device offers multiple features for managing and reducing power draw. Multiple power modes include Active, Sleep, Deep Sleep, and Hibernate. Deep Sleep has three variations based on retention of SRAM.

The power control block provides assurance that voltage levels meet the requirements of the respective modes. It can:

- Delay mode entry (for example, at power-on reset (POR)) until voltage levels are as required for proper functioning
- Detect operation below safe power supply levels:
 - Generates interrupts for low-voltage detection (LVD)
 - Generates reset for brownout detection (BOD)

The device operates using a single regulated VDDD supply within the range of 1.71 V to 3.6 V. In addition, there is an optional VBACKUP supply that can be used, which has a range of 1.4 V to 3.6 V. A linear regulator powers the core logic at four voltage levels: 0.9 V, 1.0 V, 1.1 V, and 1.2 V. Voltage level switching is implemented by writing to the power control registers. The voltage for the core logic can be set based on the application's performance and power requirements; (see [Power modes](#)). With clock gating at peripheral and bus levels, this permits fine-grained optimization of energy usage.

Typically, the backup domain requires an input voltage of 1.4 V to 3.6 V, which can be provided by connecting a backup battery or a super capacitor to the VBACKUP pin. The internal backup switch automatically selects between VDDD and VBACKUP (when VDDD is no longer available) for powering the backup domain peripherals like RTC, WCO, ILO, and Backup registers. Some I/O cells are powered from the VBACKUP supply before the internal backup switch. If the application does not require a dedicated backup source, VBACKUP can be connected to VDDD externally to ensure that the I/O cells powered by VBACKUP are functional.

The device has multiple VDDIO pins that are used to power the I/O cells except the backup domain I/O cells. VDDIO can either be connected to the same supply as VDDD or an independent supply voltage within the valid operating range. This provides more flexibility in terms of choosing the logic level for the port pins powered using different VDDIO supplies. The VDDIO supply can be switched off if the port I/Os are not used. Switching off the VDDIO supply is only allowed in Active or Deep Sleep mode. VDDIO should not be switched off when the device is in Hibernate mode. Refer to the [Pins](#) section for information about the VBACKUP or VDDIO supply used for powering the port I/O cells.

3.1.1 Power connections

The following power system diagrams show typical connections for the power pins for all the supported packages. In these diagrams, the package pin is shown with the pin name, for example, "VDD; 9".

There is no dependency on power supply sequencing.

3 Chip-level functional description

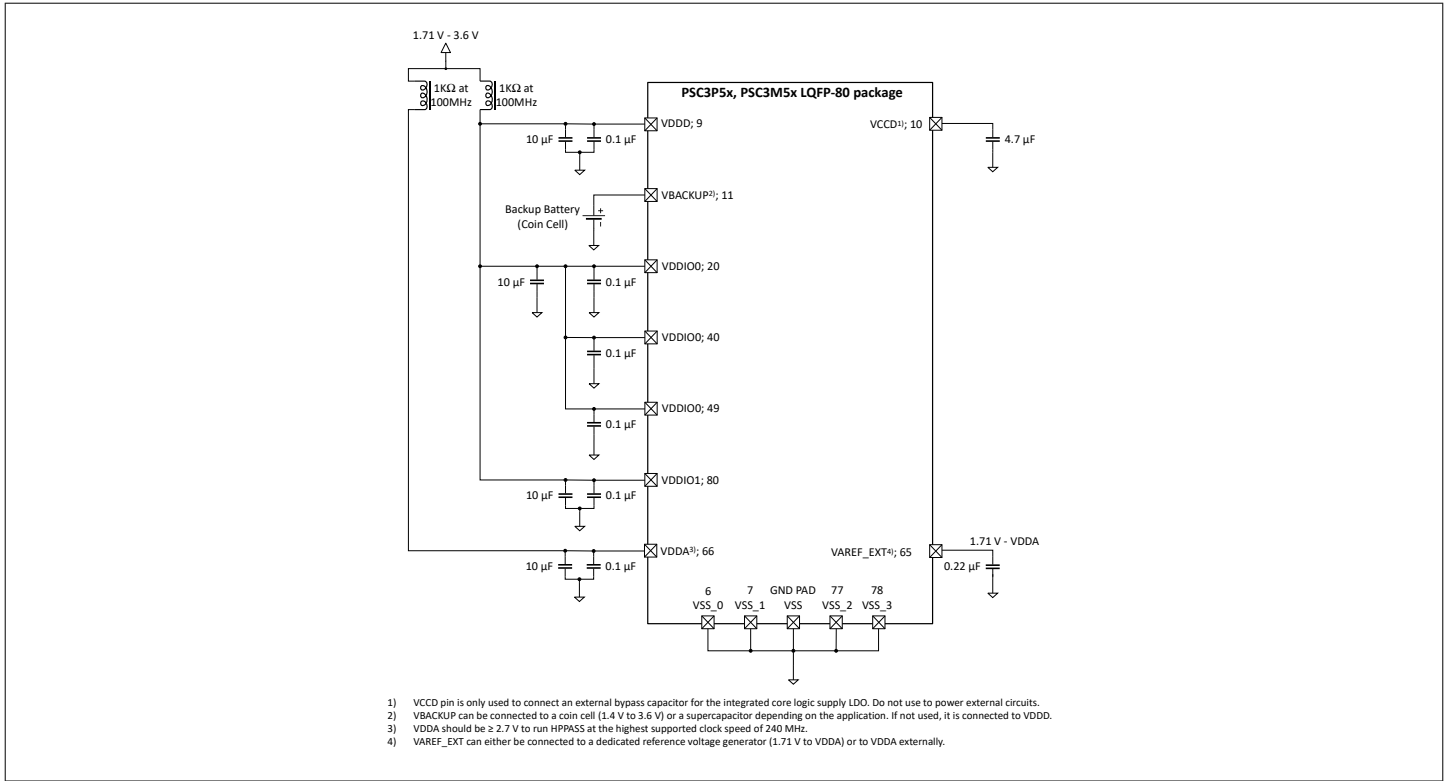

Figure 2 LQFP-80 package power connections

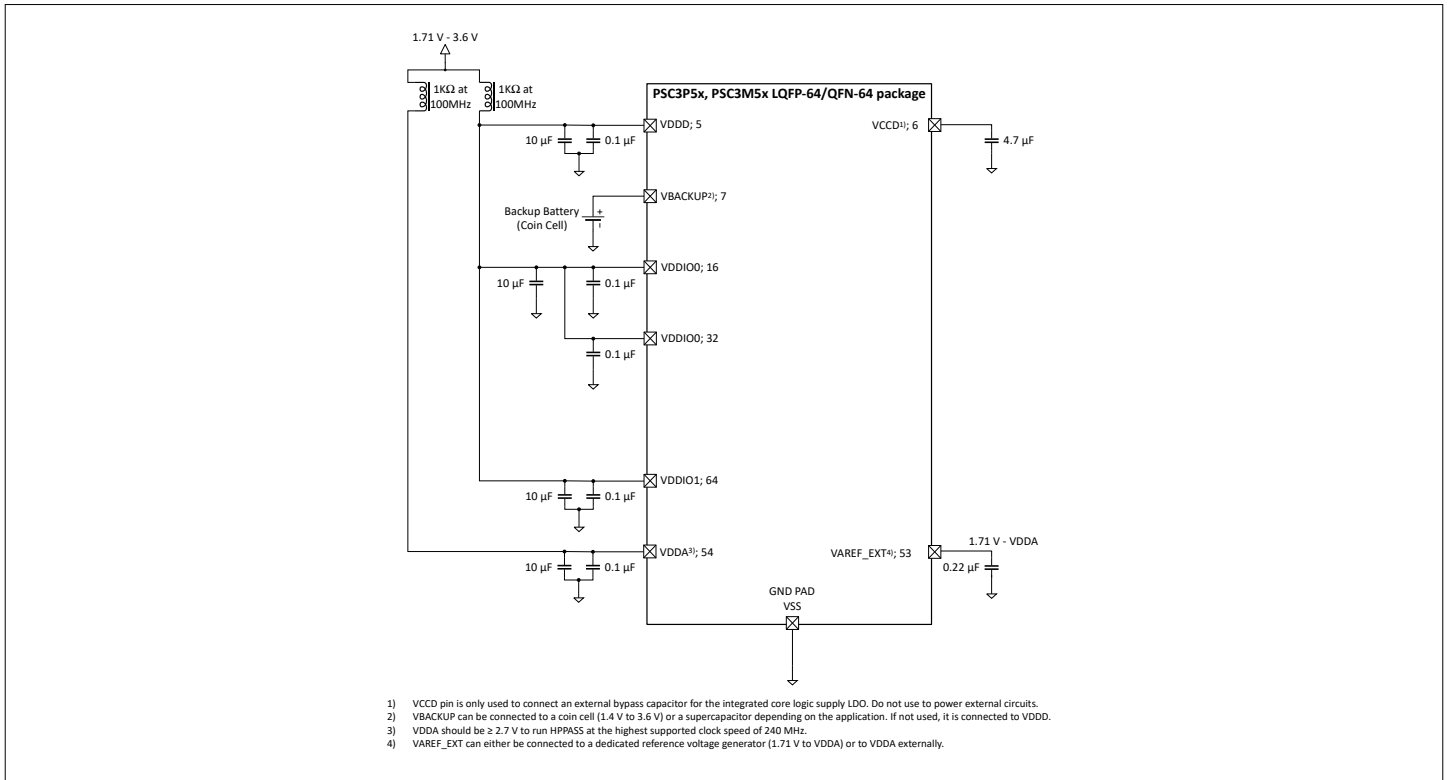

Figure 3 LQFP-64/QFN-64 package power connection

3 Chip-level functional description

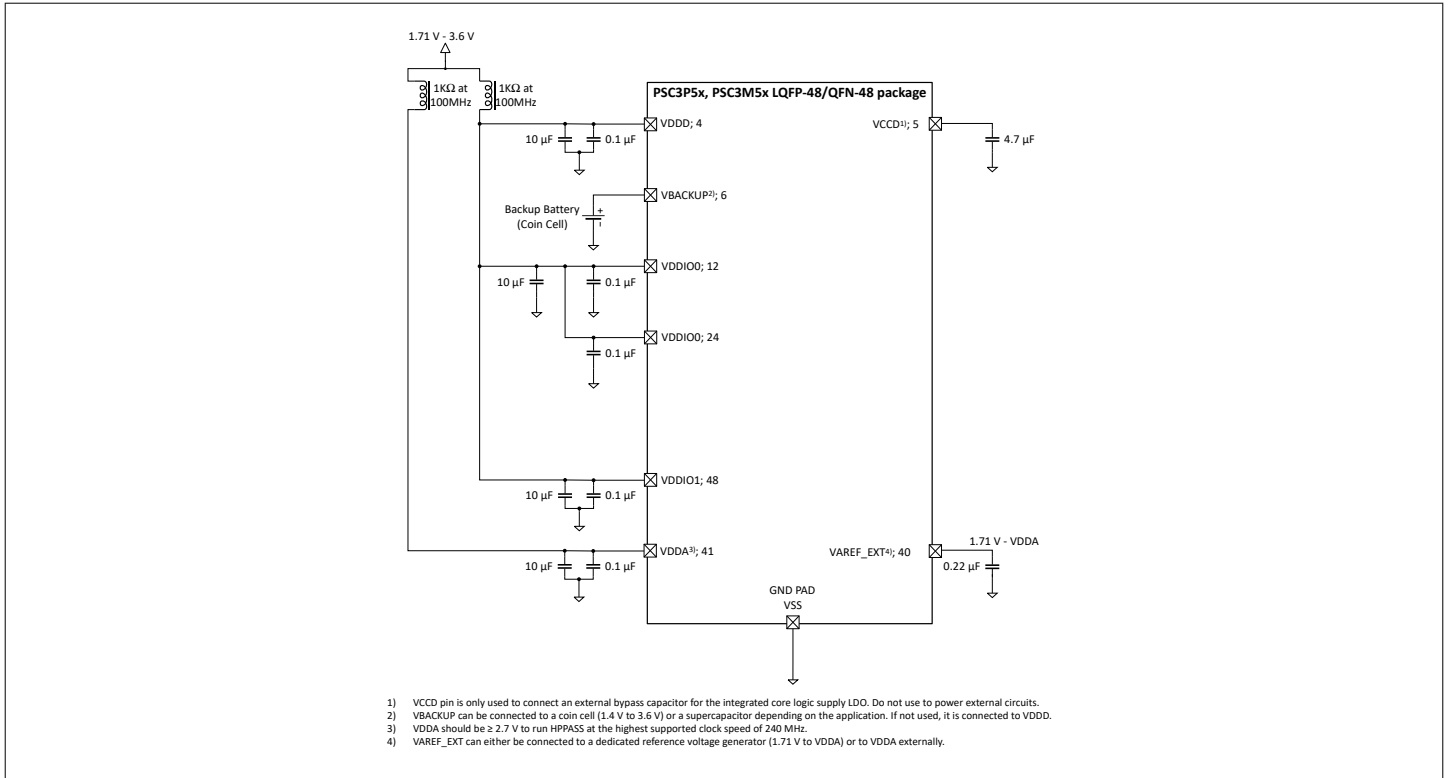

Figure 4 LQFP-48/QFN-48 package power connections

3.1.2 Power domains

The device has independent power domains, allowing the domain power to be enabled/disabled depending on the power mode.

A diagram of the power connections and routing is shown in [Figure 5](#):

3 Chip-level functional description

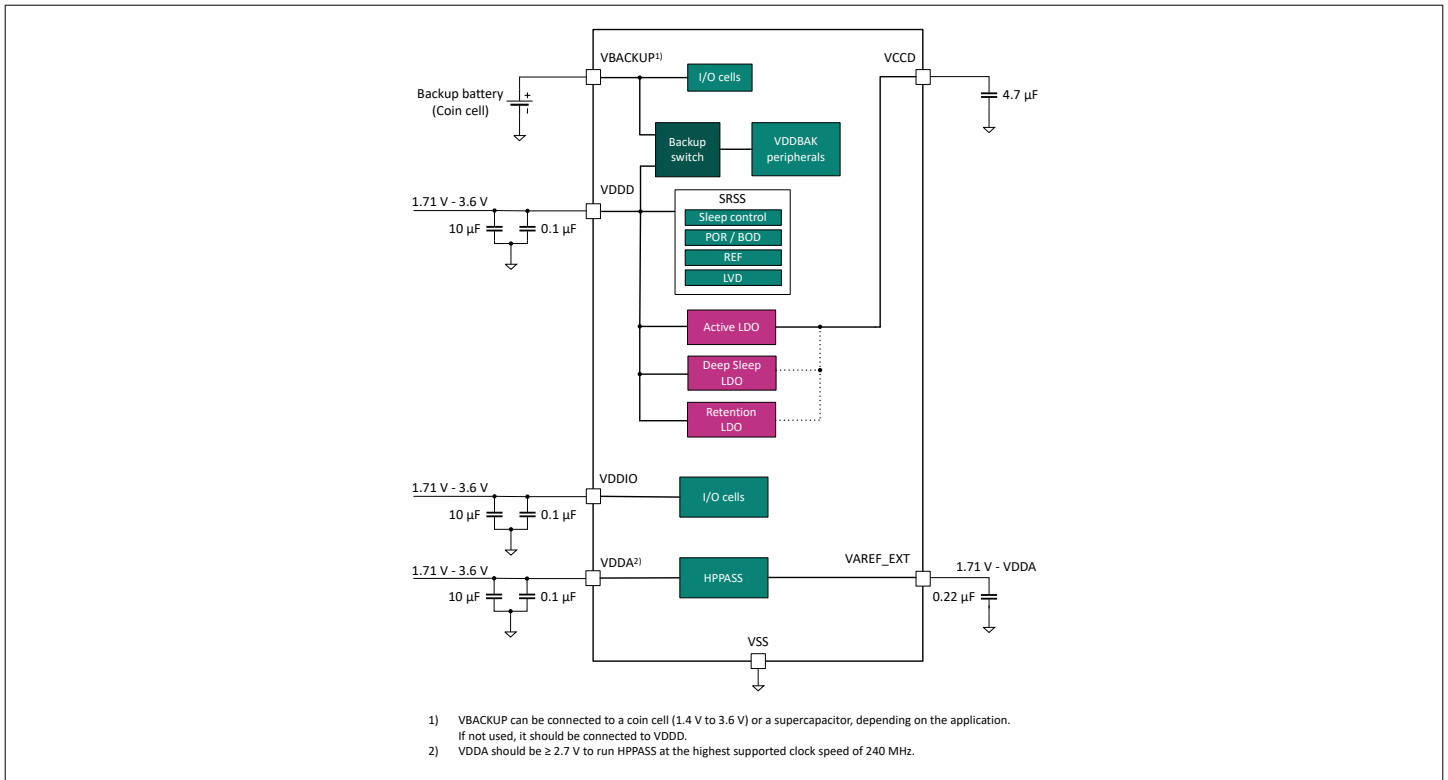

Figure 5 Power distribution and domains

3.1.3 Power modes

The device can operate in five power modes. These power modes are intended to minimize the average power consumption in an application.

Power modes supported are:

- **Active/Sleep:** All peripherals are powered. The CPU is either active and executing the code or can be put in sleep (clock gated). Any interrupt can wake up the CPU within one CPU clock cycle to resume operation. In Active/Sleep mode, the core voltage can be set to any of the four values. This impacts both power consumption and maximum clock frequency for CPU and peripherals. The following power profiles are supported in Active/Sleep mode:
 - ULP (Ultra Low Power): 0.9 V core voltage with 50 MHz CPU frequency
 - MF (Medium Frequency): 1.0 V core voltage with 70 MHz CPU frequency
 - LP (Low Power): 1.1 V core voltage with 150 MHz CPU frequency
 - OD (Overdrive): 1.2 V core voltage with 180 MHz CPU frequency
- **Deep Sleep:** The CPU is in retention mode. RAM content is also retained. Only Deep Sleep capable peripherals can wake up the system. Once awake, the operation resumes
- **Deep Sleep-RAM:** The CPU is turned off. 64 KB of SRAM is retained for a warm boot after wake-up. Only Deep Sleep-capable peripherals are operational if enabled and are capable of waking up the system
- **Deep Sleep-OFF** Same as Deep Sleep RAM except RAM is also turned off. The wake-up action is reset or cold boot
- **Hibernate:** All peripherals except LPComp and backup domain peripherals such as RTC is turned off. All clocks except the backup domain clock and all internal regulators are turned off. This results in asynchronous operation of the LPComp. The system is reset when it exits the Hibernate mode

3.1.4 Power mode transitions

The device supports Arm® standard power modes; see the [Power modes](#) section for details. [Table 1](#) lists the parameters for supported power modes:

Table 1 Power mode support

	Active/Sleep	Deep Sleep	Deep Sleep- RAM	Deep Sleep- OFF	Hibernate	Off
Parameters						
Wake source ¹⁾	Any interrupt	DS peripherals	DS peripherals	DS peripherals	RTC/HIB peripherals	Power on
Wake action	Resume	Resume	Warm boot	Reset/cold boot	Reset	Reset
Wake time	One CPU cycle	<20 μs	Deep Sleep + warm boot	Deep Sleep + cold boot	POR + cold boot < 1 ms	

Resources

ECO	On/Off	Off	Off	Off	Off	Off
IHO	On	Off	Off	Off	Off	Off
IMO	On	On/Off	Off	Off	Off	Off
ILO	On/Off	On/Off	On/Off	On/Off	On/Off	Off
WCO	On/Off	On/Off	On/Off	On/Off	On/Off	Off
CPU	On/Sleep	Retention	Off	Off	Off	Off
SRAM	On	On	On/Off	Off	Off	Off

1) See [Table 2](#) for the list of peripherals available in DS (Deep Sleep) and HIB (Hibernate) power modes.

3.1.5 Power block support

[Table 2](#) shows the available operational states for the major blocks in this device. Note that the operational states possible in low-power modes are generally limited in functionality and parametric performance as compared to their capabilities in the Active power mode. Additionally, blocks that do not support low-power modes such as Deep Sleep and Hibernate cannot wake up the CPU from these power modes. See [Power modes](#) for details.

Table 2 Block power modes

Block	Power mode				
	Active	Sleep	Deep Sleep	Hibernate	Backup
CPUSS					
CPU	Y	N	N	N	N
NVIC	Y	Y	N	N	N
WIC	Y	Y	Y	Y	N
FLASH	Y	Y	N	N	N
SRAM	Y	Y	Y	N	N

(table continues...)

Table 2 (continued) **Block power modes**

Block	Power mode				
	Active	Sleep	Deep Sleep	Hibernate	Backup
DMA	Y	Y	N	N	N
Programmable digital					
SMART I/O	Y	Y	Y	N	N
Fixed function digital					
TCPWM	Y	Y	N	N	N
SCB	Y	Y	Y ¹⁾	N	N
CAN FD	Y	Y	N	N	N
Special function					
CORDIC	Y	N	N	N	N
Analog					
HPPASS (SAR, CSG)	Y	Y	N	N	N
LPComp	Y	Y	Y ²⁾	Y	N
I/O					
GPIO	Y	Y	Y	Y ³⁾	N
Backup					
RTC	Y	Y	Y	Y	Y
Registers	Y	Y	Y	Y	Y

1) Only SCB 0 (I2C, SPI)

2) Only in Deep Sleep mode. Not available in Deep Sleep-RAM and Deep Sleep-OFF modes.

3) Only hibernate_wakeup pins (P2.0 and P9.0) are operational and capable of waking up the device from Hibernate mode. For more information, see the [Pins](#) section.

3.2 Security

Both secure and nonsecure debug accesses are supported. In nonsecure access, the debugger cannot access the areas marked as “secure”. In the secure case, the device can be “locked” such that it may not be acquired for test or debug.

Certificate management assures that appropriate accesses are provided for secure debug and RMA transition.

This device is fully compliant with Arm® TrustZone at hardware and software levels. An extra layer of security is implemented with the help of Infineon-proprietary protection units.

PSA L2-certified parts support PSA-compliant cryptographic services, key management, and secure storage services (For PSA L2 parts, see [Ordering information](#)).

3.2.1 Security features

- Arm® platform security architecture compliant with PSA level 2 precertification, depending on part number (see [Ordering information](#))
- Protected firmware feature support depending on part number (see [Ordering information](#))

3 Chip-level functional description

- Hardware crypto accelerator with comprehensive support of cryptographic algorithms
- Secure isolation of processing environments via Arm® TrustZone
- Infineon proprietary MPU, MPC, and PPCs for memory and peripheral access control
- Off-the-shelf secure isolation using Trusted Firmware-M (TF-M) and mbedTLS crypto acceleration package

3.2.2 Security architecture overview

Cortex® -M33:

- Arm® TrustZone enabled core with two processing environments: secure (SPE) and nonsecure (NSPE)
- Infineon proprietary protection units for memory and peripheral protection
- Integrated mbedTLS crypto acceleration package that supports software and hardware cryptography services
- Infineon-provided Trusted firmware-M (TF-M) implemented in SPE — its services are leveraged by Cortex® -M33 NSPE and SPE

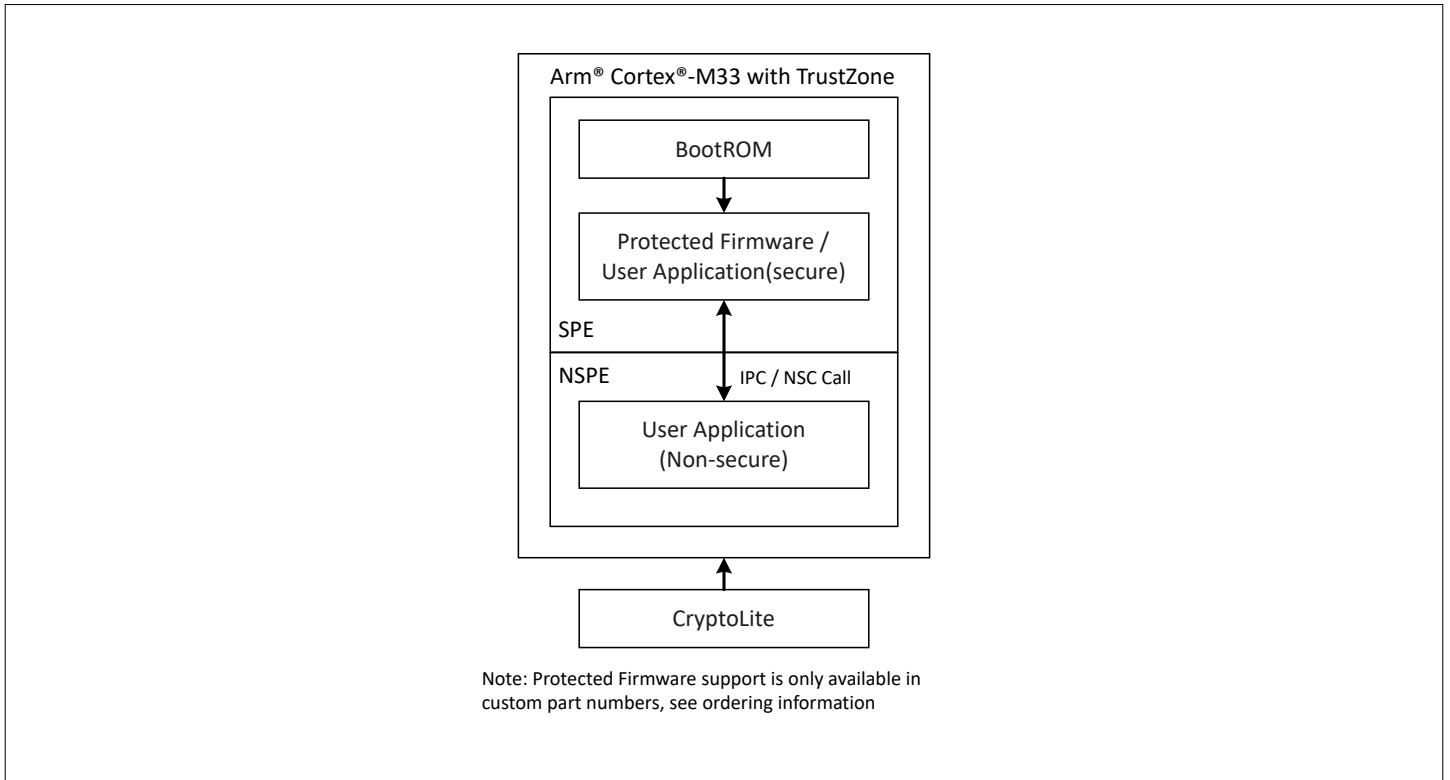

Figure 6 Security architecture diagram

4 Block functional description

4.1 CPU

- Arm® Cortex®-M33 with digital signal processor (DSP)
- Floating-point unit (FPU)
- The TrustZone framework establishes an isolated device root of trust for trusted attestation and software management
- Memory protection unit (MPU): Supports eight regions each for secure and nonsecure MPUs
- Secure attribution unit (SAU): It defines the security status of up to eight memory regions
- Debug facilities including trace (embedded trace macrocell (ETM), no embedded trace buffer (ETB))
- 16 KB I-cache for flash and ROM access

A separate 4-channel interprocessor communication (IPC) module (two IRQs) offers seamless support for semaphores and mailbox structures within secure and nonsecure execution.

The subsystems include an interrupt controller such as a nested vectored interrupt controller (NVIC). It also consists of a wake-up interrupt controller (WIC), which can wake the processor up from system Deep Sleep mode, allowing the main processor power and clocks to be turned-off when the chip is in system Deep Sleep mode.

The CPU subsystem also includes debug interfaces and supports both SWD and JTAG. The chip also supports boundary scan, which is required for testing on a PCB, and a separate test access port (TAP) controller is provided for controlling boundary scan functions.

4.2 DMA

The Cortex®-M33 CPU includes two DMA controllers that can be used to transfer data to and from memory, and peripheral registers. This allows for autonomous transfer of data from peripherals such as ADC to memory, or allows deterministic control of peripherals such as the PWM.

The DMA controllers are bus masters in their respective domains. Each DMA has 16 channels. It has a single transfer engine for all channels that arbitrates for bus master access. The DMA uses the 32-bit AHB bus that shares the same clock as the CPU.

4.3 Cryptography support (CryptoLite)

One instance of the cryptographic acceleration block that implements hardware support for true random number generator (TRNG), SHA-256, AES-128, and vector unit (VU), is provided.

4.4 Memory

The device features multiple nonvolatile and volatile memory types. The CPU and other bus masters can access any memory block. The number of wait states depends on the access path.

4.4.1 Flash

The device offer up to 256 KB of user-programmable flash. The flash supports single and dual bank modes. Dual bank mode supports the RWW feature, which allows reading from one sector while programming the other. In addition, the flash module has ECC support.

4.4.2 SFlash

The device has 32-KB supervisory flash (SFlash) memory. SFlash stores the device trim settings, secure key hashes, and FLASH_BOOT firmware. Device trim settings are used to initialize hardware resources for proper operation. Secure key hashes are used to authenticate Infineon and OEM assets and images. SFlash cannot be used to store user data.

4.4.3 ROM

All PSOC™ Control C3 devices offer 64 KB of ROM. The ROM contains boot and configuration routines and authentication checks. After a reset event, the boot code in the supervisory ROM (SROM) checks the Reset Cause register to determine whether a Hibernate event was the cause of the reset to provide the fastest possible transition to execute the user code. This minimizes the wake-up time from Hibernate mode as opposed to a power on reset (POR) or an external reset (XRES) event.

4.4.4 RAM

The device has 64 KB SRAM memory, with provision of retaining memory during Deep Sleep power mode. SRAM has ECC support for soft error detection and correction.

4.5 eFuse

The device contains 1024 one-time programmable (OTP) eFuse bits. These are reserved for system use such as device life-cycle management, trim, and hash values. eFuse bits cannot be directly programmed by the user.

Each fuse is individually programmed; once programmed (or “blown”), its state cannot be changed. Blowing a fuse transitions it from the default state of ‘0’ to ‘1’. To program an eFuse, VDDIO0 must be at 2.5 V ±10%.

Because blowing an eFuse is an irreversible process, any process requiring eFuse programming is recommended only in mass production under controlled factory conditions by Infineon provided provisioning tools.

4.6 Clock system

The PSOC™ Control C3 clock system is responsible for providing clocks to all subsystems requiring clocks and switching between different clock sources without glitching. In addition, the clock system ensures that no metastable conditions occur.

Furthermore, a clock supervision (CSV) circuit is implemented for each clk_hf domain. The CSV circuit detects a stopped clock or an abnormal frequency of the monitored clock. There are clock counters for both the monitored clock and the reference clock. Parameters for each counter define the frequency of the reference clock and the upper and lower limit for the frequency of the monitored clock.

If the dedicated frequency range comparator detects a stopped clock or a clock outside the specified frequency range, an abnormal state is signaled. Depending on the register settings and how the monitored clock is used on the device, either a reset or an interrupt is generated.

The following clock sources are provided:

- Internal main oscillator (IMO): 8 MHz ±2%, fast wake-up, low jitter
- Internal high-speed oscillator (IHO): 48 MHz ±1%
- Internal low-speed oscillator (ILO): 32 kHz ±10%, also as a wake-up source for the RTC
- External crystal oscillators (ECO and WCO)
 - External crystal oscillator (ECO): 4 MHz - 36 MHz
 - External watch crystal oscillator (WCO): 32.768 kHz
- External clock (EXTCLK): Maximum frequency 80 MHz

- One frequency lock loop (FLL) with 24 -100 MHz output range
- Two digital phase-locked loops, DPLL#0 and DPLL#1, with 25 - 250 MHz output range

Note: *FLL input clock should be at least 2.5 times less than the FLL current controlled oscillator frequency. Therefore, with FLL output divider enabled, IHO can be used as FLL input clock source only when FLL output frequency is ≥ 60 MHz.*

4.6.1 Internal main oscillator (IMO)

Internal main oscillator (IMO) operates at a fixed 8 MHz frequency. Its tolerance is $\pm 2\%$. A high-speed clock can be derived using the IMO plus a DPLL. It has fast wake-up and low jitter.

4.6.2 Internal high-frequency oscillator (IHO)

Internal high-frequency oscillator (IHO) operates at a fixed 48 MHz frequency. Its tolerance is $\pm 1\%$. A high speed-clock can be derived using the IHO plus DPLL.

4.6.3 Internal low-frequency oscillator (ILO)

The ILO is a low-power oscillator with a typical current of 0.3 μA and frequency of 32 kHz with $\pm 10\%$ accuracy. The ILO can be used as wake-up source for real-time clock (RTC)

4.6.4 External crystal oscillator (ECO)

External crystal oscillator (ECO) can use a crystal with frequency ranging from 4 MHz to 36 MHz for generating a high-precision clock. This option can be used when the precision offered by internal oscillators is not sufficient.

4.6.5 Watch crystal oscillator (WCO)

WCO uses an external 32.768 kHz crystal for applications requiring higher-precision real-time clock (RTC) functionality. WCO clock can be routed directly to the RTC for higher precision and to avoid any glitches due to internal switching of clock sources.

4.6.6 Watchdog timer (WDT)

One watchdog timer (WDT) and one multi-counter watchdog timer (MCWDT) are provided. The WDT is implemented in the clock block running from the ILO or the WCO. This allows the watchdog operation during Deep Sleep and can generate a watchdog reset if not serviced before the timeout. The watchdog reset is recorded in the Reset Cause register.

4.6.7 Real-time clock (RTC)

The device includes a real-time clock (RTC). The RTC has the following features:

- Can operate in both 12-hour format with AM/PM flag and 24-hour format
- Automatic leap year correction
- The alarm feature allows the RTC to generate an interrupt, which may be used to wake up the system from Sleep, Deep Sleep, and Hibernate power modes

4.7 Reset

The device can be reset from various sources, including a software reset. Reset events are asynchronous and ensure reversion to a known state. The reset cause (WDT, MCWDT, Faults, Debug, Software, and Clock Supervision) is recorded in a register, which is sticky through reset, and allows the software to determine the cause of the reset. An XRES pin is available for external reset.

4.8 High-performance programmable analog subsystem (HPPASS)

4.8.1 12-bit SAR analog-to-digital converter (ADC)

The device has one 12-bit SAR ADC with up to 16 parallel sampling channels. The ADC supports multiple S/H, which enables synchronous sampling on several channels.

All analog channels support individually selectable input gains of 1, 3, 6, and 12. In addition, all channels can be oversampled and averaged in hardware. The SAR ADC supports up to 12-Msps rate for a repeated conversion of the same channel. The ADC can operate with a voltage range between 1.71 V to 3.6 V (VDDA). VDDA needs to be between 2.7 V to 3.6 V for running the HPPASS at 240 MHz. The AREF_EXT pin is used to provide the ADC reference voltage. It can be connected to a precision reference voltage generator (1.71 V to VDDA) or connected externally to the AVCC pin.

The idle sampling feature allows ADC triggers to start directly from hold operation. All 16 samplers can be triggered simultaneously for simultaneous idle sampling (same hold instance) and sequential conversion (useful for multimotor, multiphase motor control and digital power applications). ADC has a sequencer with eight groups that can be programmed according to the user application. Each group defines a set of inputs that will be simultaneously sampled when that group is triggered by hardware or firmware. Each group supports the control and conversion of up to 16 samplers, and the sample time can be configured for each group. It supports two-level priority conversion. Each group can be configured to high or low-priority conversion.

The ADC has a set of built-in post processing features for the converted digital data such as averaging (result accumulation), pseudo differential mode, 2x FIR with 16 taps, 8x limit detect, 8x channel gain and offset correction coefficients with support for signed or unsigned result format. These features help in reducing CPU utilization for analog data acquisition and post processing.

The ADC can be connected to an internal temperature sensor, the value of which can be read and digitized. This is useful for calibration and other temperature-dependent functions. For more information, see [Temperature sensor](#). The ADC is not available in the Deep Sleep and Hibernate power modes.

4.8.2 Comparator and slope generator (CSG)

The device has five analog comparators that operate in Active mode. The comparator output is synchronized to avoid metastability. The comparator output can be routed to a GPIO or TCPWM (through TriggerMux), for example, as an input to kill the PWM signal if an overvoltage or over current condition is detected.

The five Active mode comparators can use the built-in 10-bit DACs or another analog input to define the programmable threshold for the comparator. The output of the DAC serves as a reference for the comparator. The DAC output is connected to the internal S/H circuit of the ADC through AMUX with other inputs. The ADC can measure the output of the comparator.

The comparator DAC values can be updated by either direct or buffered writes. This can be used for slope generation or LUT waveform generation.

The comparators can also be used in Hysteresis mode. Hysteresis voltage is configurable by the user and the comparator provides a run-time configuration for it.

4.8.3 Temperature sensor

The PSOC™ Control C3 devices contain a diode-based temperature sensor. It can be disabled to save power. The temperature sensor is connected to the SAR ADC through AMUX as one of the measurement channels. The precision of the temperature sensor output is $\pm 5^{\circ}\text{C}$ over the full operating temperature range.

4.9 Low-power comparator (LPComp)

The device provides two low-power comparators that can operate in all power modes. This allows other analog system resources to be disabled while retaining the ability to monitor external voltage levels during Deep Sleep and Hibernate modes. The comparator outputs are normally synchronized to avoid metastability unless operating in an asynchronous power mode (Hibernate) where the wake-up circuit is activated by a comparator-switch event.

4.10 Fixed function digital

4.10.1 Timer/counter pulse-width modulator (TCPWM)

The TCPWM consists of the following:

- A counter with user-programmable period/duty length PWM outputs
- A capture register to record the count value at the time of an event (which may be an I/O event)
- A period register to either stop or auto reload the counter when its count is equal to the period registers
- Compare registers to generate compare value signals that are used as PWM duty cycle outputs

The block provides accurate and complementary outputs with a programmable offset between them to allow its use as dead-band programmable complementary PWM outputs. It also has a kill input to force the outputs to a predetermined state; this can be used in motor drive and power conversion systems, for example, when an overcurrent state is indicated and the PWMs driving the FETs must be shut off immediately with no time for software intervention.

TCPWM has a Motion Interface (MOTIF) block that can be used in Hall sensor, Quadrature encoder or standalone Multichannel mode.

TCPWM also supports a high-resolution PWM (HRPWM) feature. The 32-bit four-channel TCPWM counters are enhanced with the following functionalities:

- It can program and control the PWM output signals with a typical resolution of less than 100 ps
- It can control the period, duty cycle, and dead-time with the high-resolution function

4.10.2 Serial communication block (SCB)

The PSOC™ Control C3 has up to six SCB modules, which can be software-configured for I2C, UART, or SPI interface as master or slave when in Active mode. One of the SCB modules can operate in Deep Sleep mode with an external clock with the functionality limited to I2C slave or SPI slave. Every protocol can use a 256-byte-deep FIFO per SCB module. All SCB blocks support DMA transfers.

Note: SCB4 and SCB5 not available in 48-pin devices.

4.10.2.1 Inter-integrated circuit (I2C)

The hardware I2C block implements a full multi-master and multi-slave interface and is capable of multi-master arbitration. This block can operate at speeds of up to 1 Mbps (Fast Mode Plus) and has flexible buffering options to reduce the interrupt overhead and latency for the CPU. It also supports EZI2C, which creates a mailbox address range

in the memory of the PSOC™ Control C3. This effectively reduces the I2C communication overheads for reading from and writing to an array in the memory. The FIFO significantly reduces the need for clock stretching caused by the CPU not having read the data on time.

4.10.2.2 Universal asynchronous transmitter receiver (UART)

The full-feature UART can operate at up to 8 Mbps. It supports LIN (automotive single-wire interface), IrDA (Infrared interface), and SmartCard (ISO7816) protocols. In addition, it supports the 9-bit multiprocessor mode, which allows addressing of peripherals connected over common RX and TX lines. Common UART functions such as hardware flow control, parity, break detection, and frame error are supported. The SCB can be configured in half-duplex UART mode for single-wire communication.

4.10.2.3 Serial peripheral interface (SPI)

The SPI mode supports full Motorola SPI, Texas Instruments synchronous serial port (SSP) (essentially adds a start pulse used to synchronize SPI codecs), and National Semiconductor Microwire (a half-duplex form of SPI). The SPI block also supports an EZ-SPI mode in which data interchange is reduced to reading and writing an array in memory. Fast SPI can support master and slave functionalities up to 50 MHz.

4.10.3 Controller area network flexible data-rate (CAN FD)

CAN FD features two channels including timestamp support and a 4-KB message RAM per channel. This block supports data rates of up to 8 Mbps.

4.11 Trigger multiplexer (Trigger MUX)

Trigger MUX is used to connect trigger and input/output signals between peripherals as well as GPIO pins. It can be used to connect several TCPWM counter channels to achieve multichannel support. It also provides the extended signal routing functionality such as routing any TCPWM counter PWM outputs to any GPIO pin through `peri.tr_io_output[n]` alternate function.

The trigger connections between TCPWM and HPPASS are also connected through the Trigger MUX. Any TCPWM counter can be configured to trigger any S/H circuit of the ADC inside HPPASS.

The digital comparator outputs from the ADC and analog comparator outputs are also connected to the TCPWM from the HPPASS through the Trigger MUX. It is possible to route any digital/analog comparator output to any TCPWM group and any counter inside the group.

The connections between the TCPWM and HPPASS are optimized for low latency.

4.12 Coordinate rotation digital computer (CORDIC)

CORDIC is used to precisely compute the transforms used in motor speed and position estimation as well as reference plane transforms commonly used in Field-Oriented Control (FOC). It calculates trigonometric functions in hardware to offload the processing from the main CPU. Supported algorithms include sine, cosine, arctan, sinh, cosh, arctanh, phase, sqrt, and park transform.

4.13 General-purpose input/output (GPIO) ports

The PSOC™ Control C3 provides up to 50 GPIO pads with two pad-power-supply domains. Two of the GPIOs are multiplexed with analog inputs, making it possible to have a maximum of 18 analog input connections. The GPIO block has the following features:

4 Block functional description

- Eight drive modes including strong push-pull, resistive pull-up and pull-down, open-drain and open-source, input-only, and disabled
- Analog signal input capability (I/O buffers disabled; signal passed through switches)
- Input threshold select (CMOS or LVTTTL)
- Individual control of input and output disables
- Hold mode for latching the previous state (used for retaining the I/O state in Deep Sleep and Hibernate modes)
- Selectable slew rates for dV/dt-related noise control

The pins are organized in logical entities called "ports". During power-on and reset, the blocks are forced to the disabled state so they do not crowbar any inputs and/or cause excess turn-on current. A multiplexing network known as a "high-speed I/O matrix" (HSIOM) is used to multiplex between various signals that may connect to an I/O pin.

Data Output and Pin State registers store the values to be driven on the pins and the pins' states.

Every I/O pin can generate an interrupt if so enabled, and each I/O port has an interrupt request (IRQ) and interrupt service routine (ISR) vector associated with it.

The I/O ports will retain their state during Hibernate mode. If the operation is restored using Reset, then the pins will go to the High-Z state; if the operation is restored by using the wake-up pin, the pin drivers will retain their previously frozen state until the firmware chooses to change it.

Simultaneous output switching in high-current mode requires attention to line termination and decoupling capacitor size to control switching transient voltages.

4.14 Smart I/O (Programmable I/O)

Each smart I/O block contains eight programmable LUT arrays out of which up to six LUT arrays are associated with a particular I/O port that allows integration of board-level glue logic and Boolean functions at the pins. The remaining free LUT arrays can be connected to the I/O LUT array outputs for creating more complex logic functions. It is similar to programmable array logic (PAL) or small programmable logic devices (PLDs). The smart I/O block is interposed between the port pins and the HSIOM (responsible for multiplexing signals from on-chip peripherals to and from the port pins) and the digital signal interconnect (DSI) signals. It is possible to bypass the smart I/O block in order not to impact the propagation delay for critical paths from the DSI to the port pins.

4 Block functional description

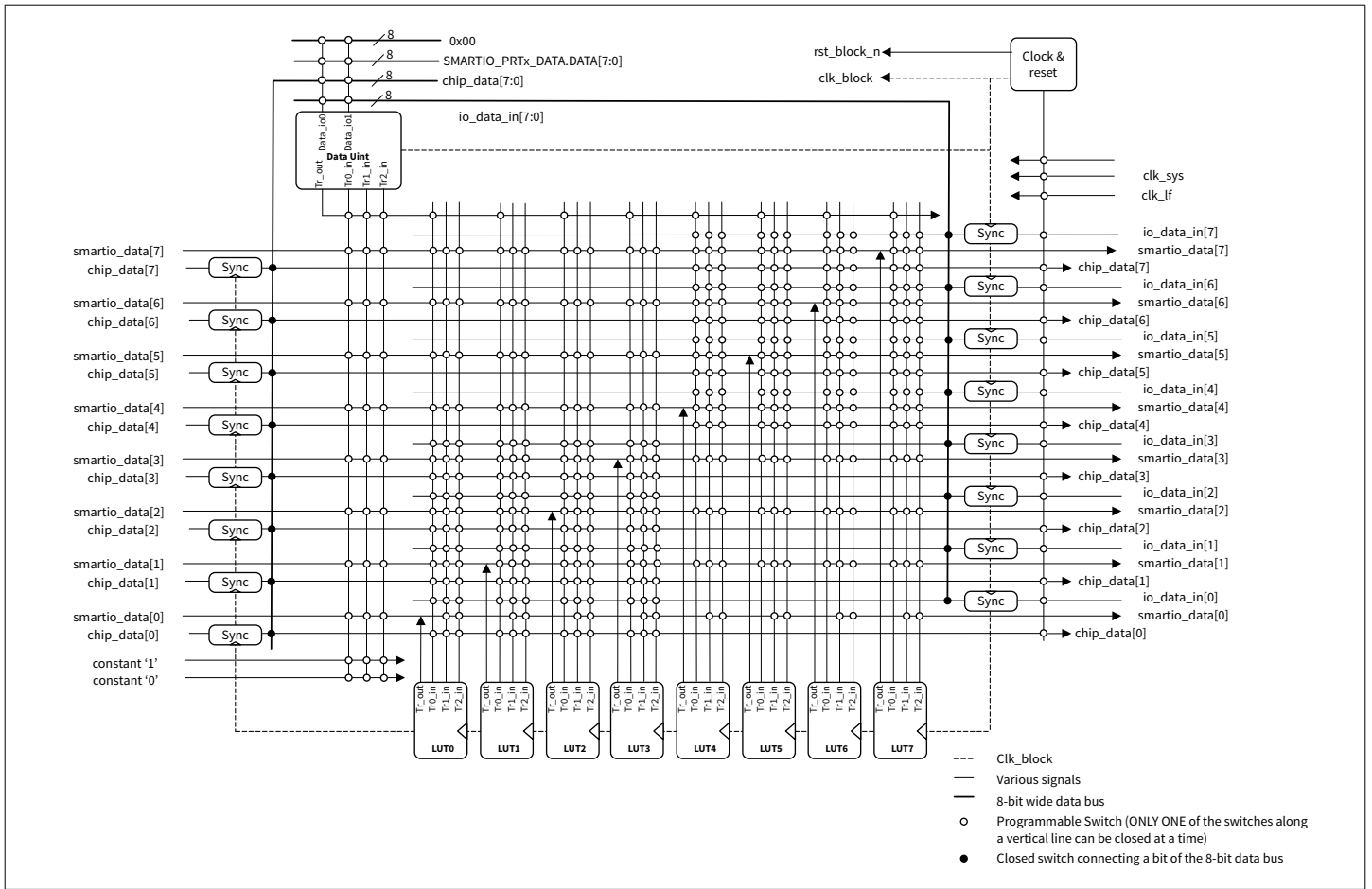

Figure 7 Smart I/O block diagram

The structure is interposed between the GPIO port and the HSIOM.

4.15 Device firmware update (DFU)

The boot ROM supports firmware updates using a serial port. DFU functionality is disabled by default. It needs to be enabled in the OEM policy before use. Contact [Infineon support](#) for details. When enabled, DFU mode selection is initiated during device boot-up depending on the state of P2.2 and P2.3 pins as shown in the table:

Table 3 DFU mode selection

P2.3 pin state	P2.2 pin state	DFU mode
High-Z	High-Z	Disable
High-Z	X	Disable
X	High-Z	Disable
Low	Low	Disable
Low	High	I2C
High	Low	UART
High	High	SPI

X = Don't care

4 Block functional description

Use pull-up or pull-down resistors of 1 kΩ or less connected to VDDIO_0 or VSS to set these pins to logic high or low. Pins can be left floating for High-Z state. When the device is in DFU mode, the following pins are used for serial communication:

Table 4 DFU serial communication pins

Pin	I2C	UART	SPI
P8.0			CS
P8.1	SCL	RX	MOSI
P8.2			MISO
P8.3	SDA	TX	CLK

The following parameters are used for the DFU communication protocols:

- I2C: Speed = 400 kHz, Mode = Slave, 7-bit address, address = 0x35
- UART: Baud = 115200, Bits = 8, Stop Bits = 1, RTS/CTS = No, Parity = None
- SPI: Mode = Slave, Motorola 00 (MSB first, CPHA = 0, CPOL = 0), Speed ≤ 12 Mbps

Note: *Boot ROM DFU support is available only in 80-pin and 64-pin devices.*

4.16 Serial wire JTAG debug port/Embedded trace macrocell

Serial wire JTAG debug port (SWJ-DP)

The PSOC™ Control C3 MCU embeds the ARM® serial wire JTAG debug port (SWJ-DP) which supports 2-wire Serial Wire Debug (SWD) and 4-wire or 5-wire Joint Test Action Group (JTAG) interface. SWD interface is enabled by default after power on and JTAG interface is in disabled state. JTAG can be enabled in 4-wire or 5-wire mode by updating the OEM policy. Contact [Infineon support](#) for details.

Embedded trace macrocell (ETM)

Arm® embedded trace macrocell is supported by the PSOC™ Control C3. It allows reconstruction of program execution using high speed compressed data transmitted on the ETM pins. ETM interface includes a clock (trace.clock) pin and up to four data (trace.data0 to trace.data3) pins.

5 Pins

GPIO ports and analog inputs are powered by VDDx pins as follows:

- P0: VBACKUP
- P1, P2, P3, P4, P5, P6, P7: VDDIO_0
- P8, P9: VDDIO_1
- AN_A, AN_B: AVDD

The number of GPIOs is limited in some packages. The E-LQFP-80 package has the full 50 GPIOs and 16 dedicated analog inputs; the E-LQFP-64/VQFN-64 package has 39 GPIOs and 16 dedicated analog inputs; the E-LQFP-48/VQFN-48 package has 29 GPIOs and 10 dedicated analog inputs. For detailed information on the supported packages, see [Package information](#) section.

Table 5 Packages and pin information

Pin	Capability	Packages		
		E-LQFP-80	E-LQFP-64/VQFN-64	E-LQFP-48/VQFN-48
VDDD	-	9	5	4
VDDA	-	66	54	41
VDDIO_0_0	-	20	16	12
VDDIO_0_1	-	40	32	24
VDDIO_0_2	-	49	-	-
VDDIO_1	-	80	64	48
VCCD	-	10	6	5
VSS	-	GND PAD	GND PAD	GND PAD
VSS_0	-	6	-	-
VSS_1	-	7	-	-
VSS_2	-	77	-	-
VSS_3	-	78	-	-
VAREF_EXT	-	65	53	40
VBACKUP	-	11	7	6
AN_A0	AD	53	41	31
AN_A1	AD	54	42	32
AN_A2	AD	55	43	33
AN_A3	AD	56	44	34
AN_A4	AD	57	45	35
AN_A5	AD	58	46	36
AN_A6	AD	59	47	-
AN_A7	AD	60	48	-
AN_B0	AD	61	49	-
AN_B1	AD	62	50	37
AN_B2	AD	63	51	38
AN_B3	AD	64	52	39
AN_B4	AM	67	55	42

(table continues...)

Table 5 (continued) Packages and pin information

Pin	Capability	Packages		
		E-LQFP-80	E-LQFP-64/VQFN-64	E-LQFP-48/VQFN-48
AN_B5	AM	68	56	-
AN_B6	AM	69	57	-
AN_B7	AM	70	58	-
XRES	-	8	4	3
P0.0	S	12	8	7
P0.1	S	13	9	-
P1.0	S	14	10	-
P1.1	S	15	11	-
P1.2	S	16	12	8
P1.3	S	17	13	9
P2.0	S	18	14	10
P2.1	S	19	15	11
P2.2	S	21	17	13
P2.3	S	22	18	14
P3.0	S	23	-	-
P3.1	S	24	-	-
P3.2	S	25	-	-
P3.3	S	26	-	-
P4.0	-	27	19	15
P4.1	-	28	20	16
P4.2	-	29	21	17
P4.3	-	30	22	18
P4.4	-	31	23	19
P4.5	-	32	24	20
P4.6	-	33	25	21
P4.7	-	34	26	22
P5.0	S	35	27	-
P5.1	S	36	28	-
P5.2	S	37	29	-
P5.3	S	38	30	-
P6.0	S	39	31	23
P6.1	S	41	33	25
P6.2	S	42	34	26
P6.3	S	43	35	27
P7.0	-	44	36	28

(table continues...)

Table 5 (continued) Packages and pin information

Pin	Capability	Packages		
		E-LQFP-80	E-LQFP-64/VQFN-64	E-LQFP-48/VQFN-48
P7.1	-	45	37	29
P7.2	-	46	38	30
P7.3	-	47	39	-
P7.4	-	48	40	-
P7.5	-	50	-	-
P7.6	-	51	-	-
P7.7	-	52	-	-
P8.0	AM, AC	71	59	43
P8.1	AM	72	60	44
P8.2	AM, AC	73	61	45
P8.3	AM	74	62	46
P8.4	-	75	-	-
P8.5	-	76	-	-
P9.0	S	79	63	47
P9.1	S	1	1	-
P9.2	S	2	2	1
P9.3	S	3	3	2
P9.4	S	4	-	-
P9.5	S	5	-	-

Table 6 Pin capability abbreviations

Abbreviation	Capability
AD	Dedicated analog pin directly connected to sampler
AM	Dedicated analog pin/analog capable GPIO pin connected to sampler through MUX
AC	Analog capable GPIO pin (LPComp input)
S	Smart IO capable GPIO

Notes:

1. All GPIO pins are PWM capable. Any TCPWM channel line or line_compl output can be routed to any GPIO pin
2. Number of LUTs is not impacted by the number of Smart IO capable GPIO pins available in lower pin count packages

5 Pins

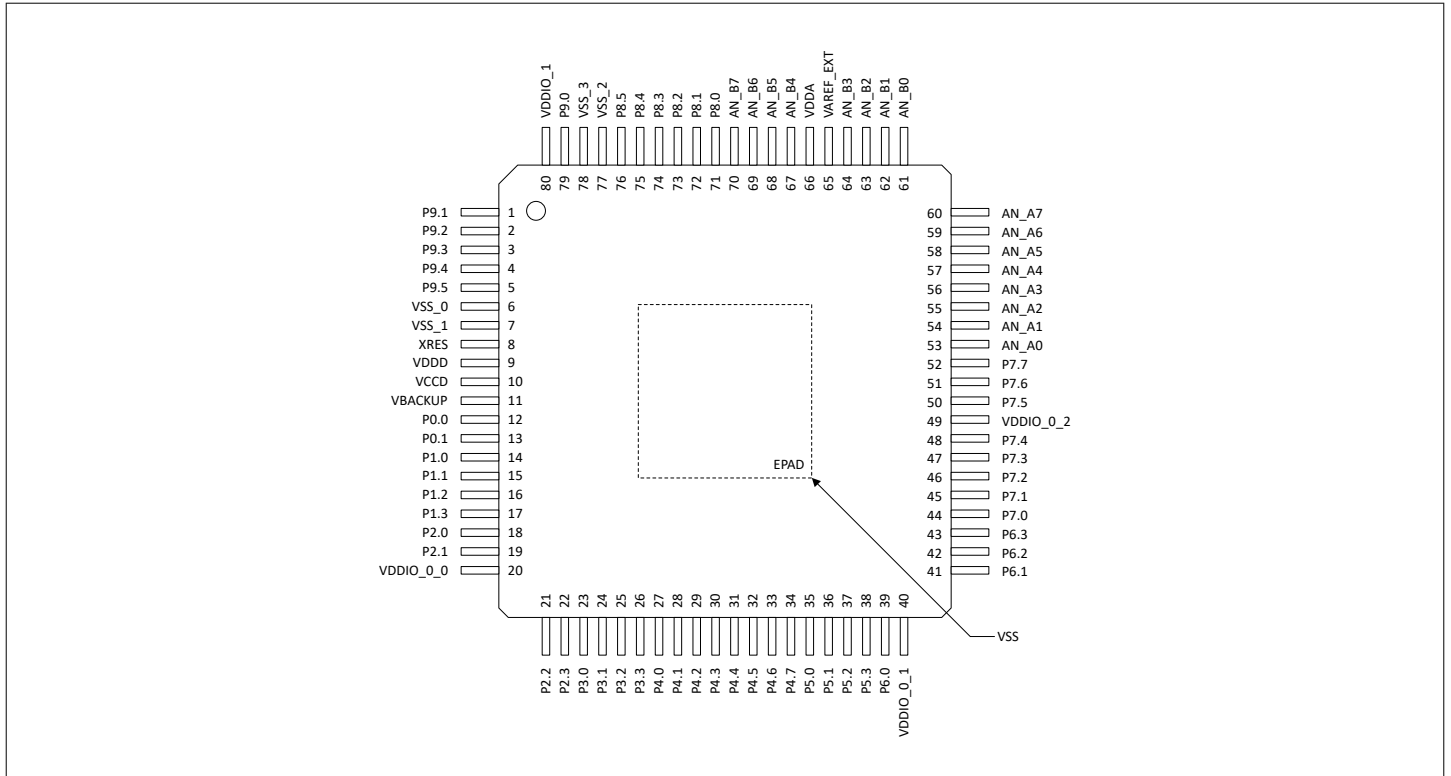

Figure 8 Device pinout for E-LQFP-80 package (top view)

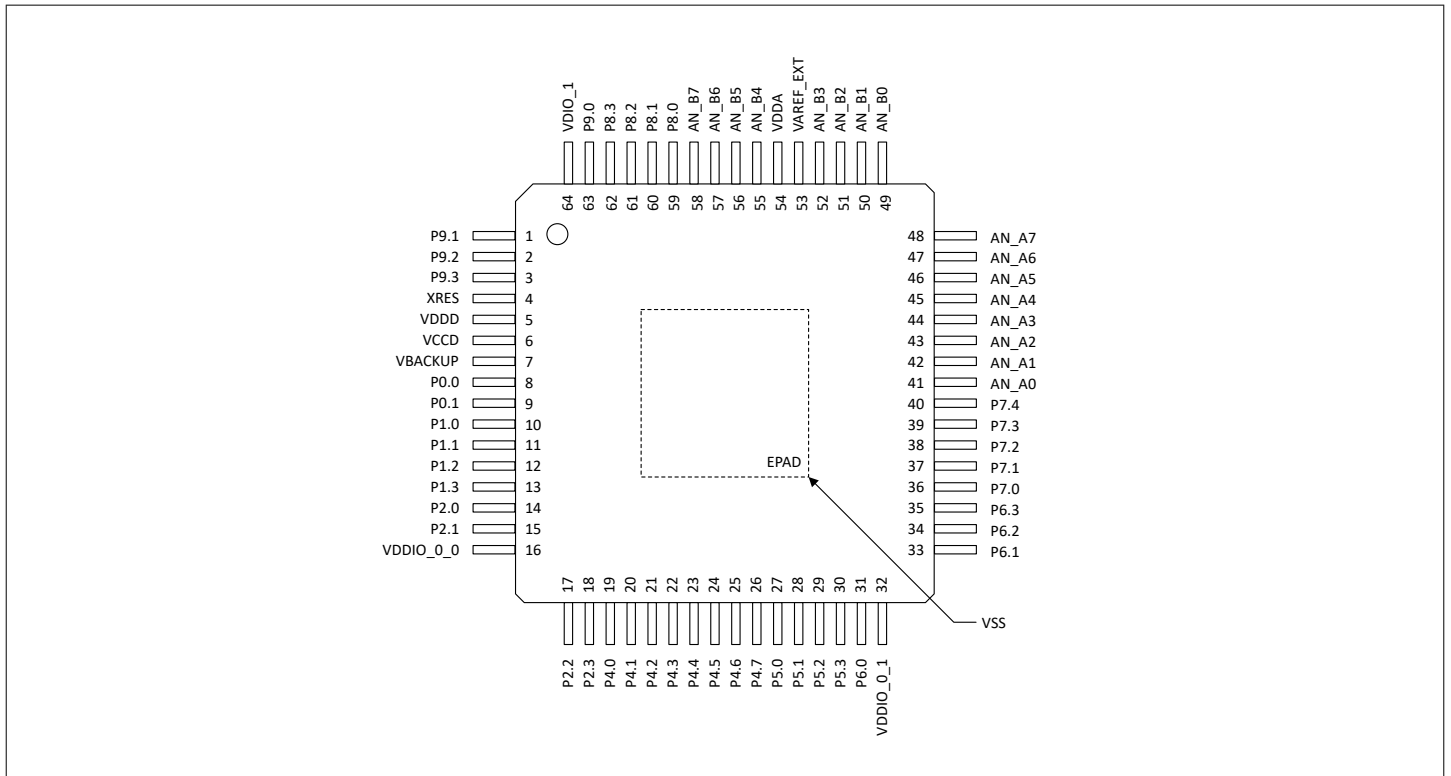

Figure 9 Device pinout for E-LQFP-64 package (top view)

5 Pins

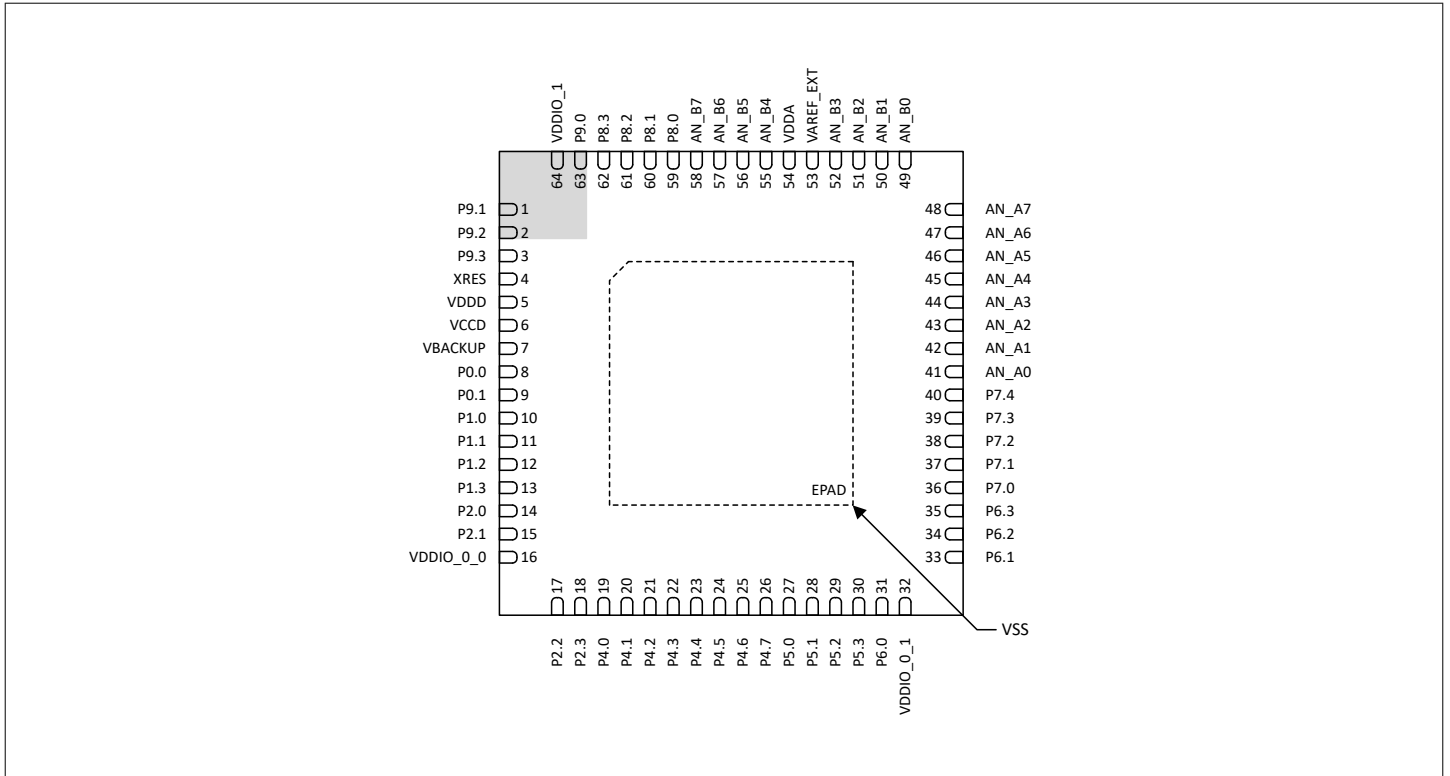

Figure 10 Device pinout for VQFN-64 package (top view)

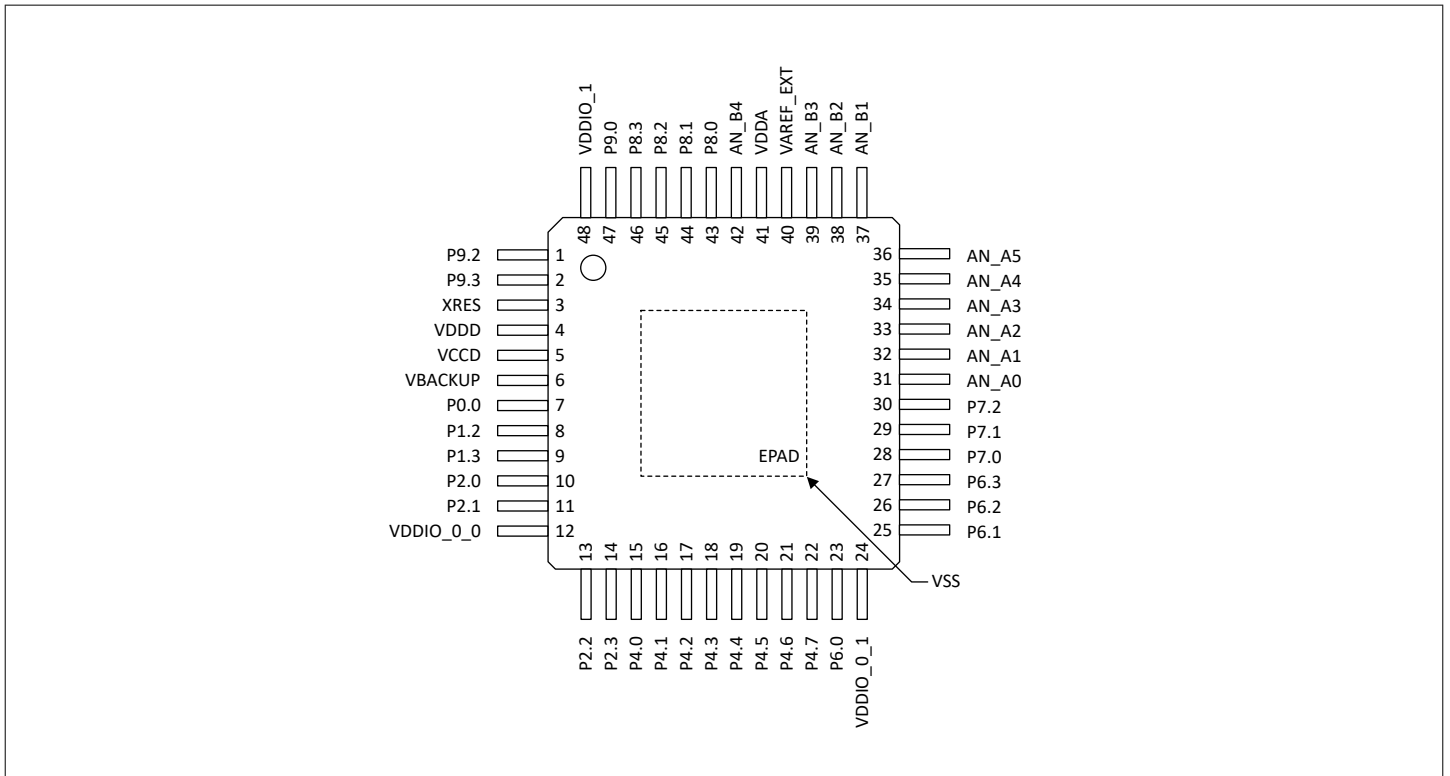

Figure 11 Device pinout for E-LQFP-48 package (top view)

6 GPIO alternate functions tables

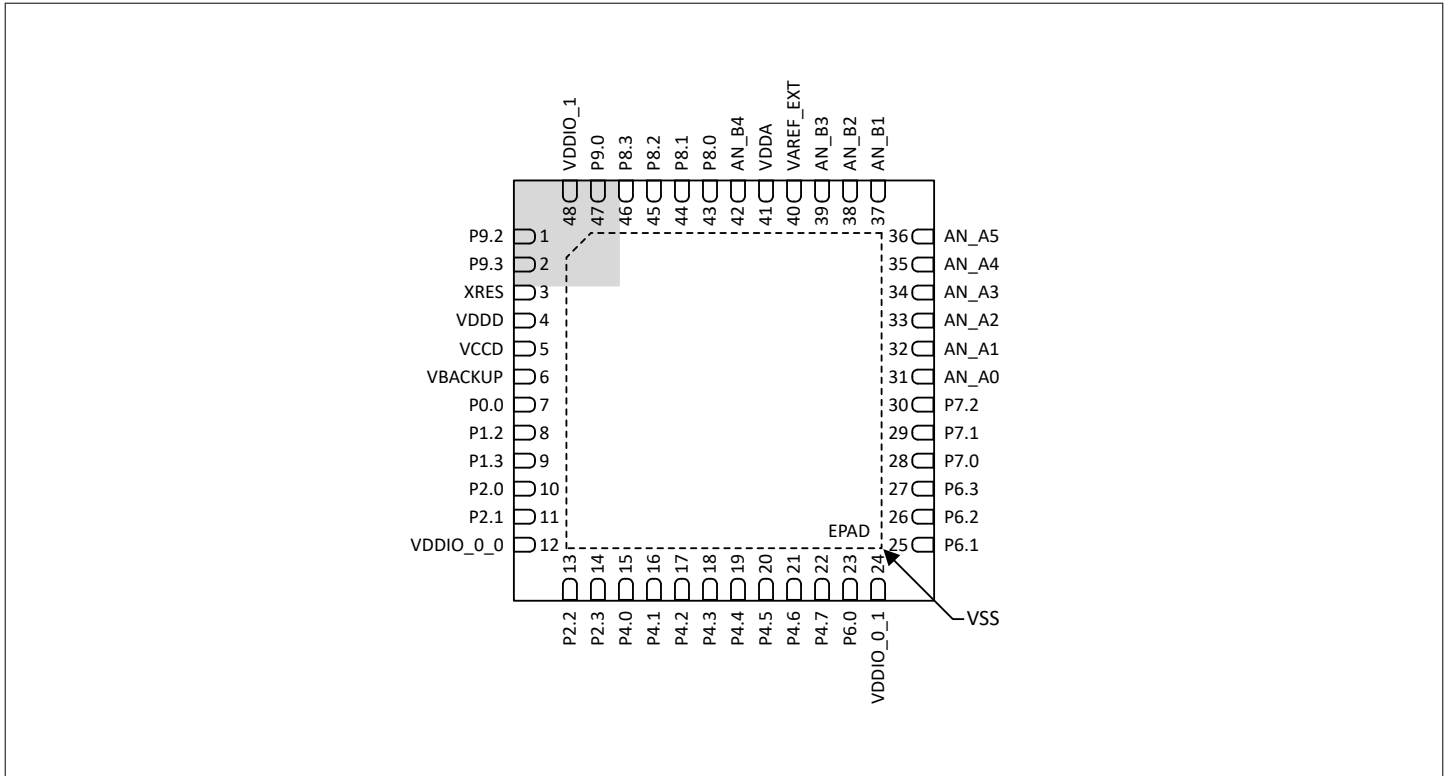

Figure 12 Device pinout for VQFN-48 package (top view)

6 GPIO alternate functions tables

Table 7 GPIO alternate functions and HSIOM routes

GPIO	Alternate functions and HSIOM routes			
P0.0	wco_out	fixed	smartio0.io0	fixed
	ext_clk	ACT #8	peri.tr_io_input[0]:0	ACT #14
	peri.tr_io_output[0]:0	ACT #15		
P0.1	wco_in	fixed	smartio0.io1	fixed
	peri.tr_io_input[1]:0	ACT #14	peri.tr_io_output[1]:0	ACT #15
P1.0	eco_in	fixed	smartio1.io0	fixed
	peri.tr_io_output[58]:1	ACT #1	peri.tr_io_output[70]:1	ACT #2
	scb1.uart.cts	ACT #4	scb1.spi.select0	ACT #6
	peri.tr_io_input[2]:0	ACT #14	peri.tr_io_output[2]:0	ACT #15
P1.1	eco_out	fixed	smartio1.io1	fixed
	peri.tr_io_output[59]:1	ACT #1	peri.tr_io_output[71]:1	ACT #2
	scb1.uart.rts	ACT #4	scb1.spi.clk	ACT #6
	peri.tr_io_input[3]:0	ACT #14	peri.tr_io_output[3]:0	ACT #15

(table continues...)

Table 7 (continued) GPIO alternate functions and HSIOM routes

GPIO	Alternate functions and HSIOM routes			
P1.2	smartio1.io2	fixed	peri.tr_io_output[60]:1	ACT #1
	peri.tr_io_output[72]:1	ACT #2	scb1.uart.rx	ACT #4
	scb1.spi.mosi	ACT #6	scb1.i2c.sda	ACT #7
	peri.tr_io_input[4]:0	ACT #14	peri.tr_io_output[4]:0	ACT #15
	swj.swclk/tclk	DS #5		
P1.3	smartio1.io3	fixed	peri.tr_io_output[61]:1	ACT #1
	peri.tr_io_output[73]:1	ACT #2	scb1.uart.tx	ACT #4
	scb1.spi.miso	ACT #6	scb1.i2c.scl	ACT #7
	peri.tr_io_input[5]:0	ACT #14	peri.tr_io_output[5]:0	ACT #15
	swj.swdio/tms	DS #5		
P2.0	hibernate_wakeup	fixed	smartio2.io0	fixed
	peri.tr_io_output[58]:0	ACT #1	tcpwm0.g2.cnt6+	ACT #2
	scb1.uart.cts	ACT #4	scb1.spi.select0	ACT #6
	peri.tr_io_input[6]:0	ACT #14	peri.tr_io_output[6]:0	ACT #15
	swj.tdi	DS #5		
P2.1	smartio2.io1	fixed	peri.tr_io_output[59]:0	ACT #1
	tcpwm0.g2.cnt6-	ACT #2	cal_wave	DS #0
	scb1.uart.rts	ACT #4	scb1.spi.clk	ACT #6
	scb1.i2c.scl	ACT #7	peri.tr_io_input[7]:0	ACT #14
	peri.tr_io_output[7]:0	ACT #15	swj.tdo	DS #5
P2.2	smartio2.io2	fixed	peri.tr_io_output[60]:0	ACT #1
	tcpwm0.g2.cnt7+	ACT #2	scb1.uart.rx	ACT #4
	scb1.spi.mosi	ACT #6	scb1.i2c.sda	ACT #7
	ext_clk	ACT #8	peri.tr_io_input[8]:0	ACT #14
	peri.tr_io_output[8]:0	ACT #15		
P2.3	smartio2.io3	fixed	peri.tr_io_output[61]:0	ACT #1
	tcpwm0.g2.cnt7-	ACT #2	scb1.uart.tx	ACT #4
	scb1.spi.miso	ACT #6	peri.tr_io_input[9]:0	ACT #14
	peri.tr_io_output[9]:0	ACT #15		
P3.0	smartio3.io0	fixed	peri.tr_io_output[62]:0	ACT #1
	scb4.uart.cts	ACT #4	scb4.spi.mosi	ACT #6
	peri.tr_io_input[10]:0	ACT #14	peri.tr_io_output[10]:0	ACT #15

(table continues...)

Table 7 (continued) GPIO alternate functions and HSIOM routes

GPIO	Alternate functions and HSIOM routes			
P3.1	smartio3.io1	fixed	peri.tr_io_output[63]:0	ACT #1
	scb4.uart.rts	ACT #4	scb4.spi.miso	ACT #6
	scb4.i2c.sda	ACT #7	peri.tr_io_input[11]:0	ACT #14
	peri.tr_io_output[11]:0	ACT #15		
P3.2	smartio3.io2	fixed	peri.tr_io_output[64]:0	ACT #1
	scb4.uart.rx	ACT #4	scb4.spi.clk	ACT #6
	scb4.i2c.scl	ACT #7	peri.tr_io_input[12]:0	ACT #14
	peri.tr_io_output[12]:0	ACT #15		
P3.3	smartio3.io3	fixed	peri.tr_io_output[65]:0	ACT #1
	scb4.uart.tx	ACT #4	scb4.spi.select0	ACT #6
	peri.tr_io_input[13]:0	ACT #14	peri.tr_io_output[13]:0	ACT #15
P4.0	peri.tr_io_output[50]:0	ACT #0	tcpwm0.g1.cnt4+	ACT #1
	scb4.uart.cts	ACT #4	scb4.spi.mosi	ACT #6
	peri.tr_io_input[14]:0	ACT #14	peri.tr_io_output[14]:0	ACT #15
P4.1	peri.tr_io_output[51]:0	ACT #0	tcpwm0.g1.cnt4-	ACT #1
	scb4.uart.rts	ACT #4	scb4.spi.miso	ACT #6
	scb4.i2c.sda	ACT #7	peri.tr_io_input[15]:0	ACT #14
	peri.tr_io_output[15]:0	ACT #15		
P4.2	peri.tr_io_output[52]:0	ACT #0	tcpwm0.g1.cnt5+	ACT #1
	scb4.uart.rx	ACT #4	scb4.spi.clk	ACT #6
	scb4.i2c.scl	ACT #7	peri.tr_io_input[16]:0	ACT #14
	peri.tr_io_output[16]:0	ACT #15		
P4.3	peri.tr_io_output[53]:0	ACT #0	tcpwm0.g1.cnt5-	ACT #1
	scb4.uart.tx	ACT #4	scb4.spi.select0	ACT #6
	peri.tr_io_input[17]:0	ACT #14	peri.tr_io_output[17]:0	ACT #15
P4.4	peri.tr_io_output[54]:0	ACT #0	tcpwm0.g1.cnt6+	ACT #1
	peri.tr_io_input[18]:0	ACT #14	peri.tr_io_output[18]:0	ACT #15
P4.5	peri.tr_io_output[55]:0	ACT #0	tcpwm0.g1.cnt6-	ACT #1
	peri.tr_io_input[19]:0	ACT #14	peri.tr_io_output[19]:0	ACT #15
P4.6	peri.tr_io_output[56]:0	ACT #0	tcpwm0.g1.cnt7+	ACT #1
	peri.tr_io_input[20]:0	ACT #14	peri.tr_io_output[20]:0	ACT #15
P4.7	peri.tr_io_output[57]:0	ACT #0	tcpwm0.g1.cnt7-	ACT #1
	peri.tr_io_input[21]:0	ACT #14	peri.tr_io_output[21]:0	ACT #15

(table continues...)

Table 7 (continued) GPIO alternate functions and HSIOM routes

GPIO	Alternate functions and HSIOM routes			
P5.0	smartio5.io0	fixed	peri.tr_io_output[62]:1	ACT #1
	scb3.uart.cts	ACT #4	scb3.spi.mosi	ACT #6
	scb3.i2c.sda	ACT #7	peri.tr_io_input[22]:0	ACT #14
	peri.tr_io_output[22]:0	ACT #15		
P5.1	smartio5.io1	fixed	peri.tr_io_output[63]:1	ACT #1
	scb3.uart.rts	ACT #4	scb3.spi.miso	ACT #6
	scb3.i2c.scl	ACT #7	peri.tr_io_input[23]:0	ACT #14
	peri.tr_io_output[23]:0	ACT #15		
P5.2	smartio5.io2	fixed	peri.tr_io_output[64]:1	ACT #1
	can1.rx	ACT #3	scb3.uart.rx	ACT #4
	scb3.spi.clk	ACT #6	peri.tr_io_input[24]:0	ACT #14
	peri.tr_io_output[24]:0	ACT #15		
P5.3	smartio5.io3	fixed	peri.tr_io_output[65]:1	ACT #1
	can1.tx	ACT #3	scb3.uart.tx	ACT #4
	scb3.spi.select0	ACT #6	peri.tr_io_input[25]:0	ACT #14
	peri.tr_io_output[25]:0	ACT #15		
P6.0	smartio6.io0	fixed	tcpwm0.g1.cnt4+	ACT #1
	peri.tr_io_output[66]:0	ACT #2	scb3.uart.cts	ACT #4
	scb3.spi.mosi	ACT #6	scb3.i2c.sda	ACT #7
	peri.tr_io_input[26]:0	ACT #14	peri.tr_io_output[26]:0	ACT #15
P6.1	smartio6.io1	fixed	tcpwm0.g1.cnt4-	ACT #1
	peri.tr_io_output[67]:0	ACT #2	scb3.uart.rts	ACT #4
	scb3.spi.miso	ACT #6	scb3.i2c.scl	ACT #7
	peri.tr_io_input[27]:0	ACT #14	peri.tr_io_output[27]:0	ACT #15
P6.2	smartio6.io2	fixed	tcpwm0.g1.cnt5+	ACT #1
	peri.tr_io_output[68]:0	ACT #2	can1.rx	ACT #3
	scb3.uart.rx	ACT #4	scb3.spi.clk	ACT #6
	peri.tr_io_input[28]:0	ACT #14	peri.tr_io_output[28]:0	ACT #15
P6.3	smartio6.io3	fixed	tcpwm0.g1.cnt5-	ACT #1
	peri.tr_io_output[69]:0	ACT #2	can1.tx	ACT #3
	scb3.uart.tx	ACT #4	scb3.spi.select0	ACT #6
	cpuss.fault[0]:1	ACT #9	peri.tr_io_input[29]:0	ACT #14
	peri.tr_io_output[29]:0	ACT #15		

(table continues...)

Table 7 (continued) GPIO alternate functions and HSIOM routes

GPIO	Alternate functions and HSIOM routes			
P7.0	peri.tr_io_output[50]:1	ACT #0	tcpwm0.g1.cnt6+	ACT #1
	peri.tr_io_output[70]:0	ACT #2	scb2.uart.cts	ACT #4
	scb2.spi.clk	ACT #5	scb2.i2c.scl	ACT #7
	trace.data0	ACT #9	hppass.gpio_out0	ACT #12
	peri.tr_io_input[30]:0	ACT #14	peri.tr_io_output[30]:0	ACT #15
P7.1	peri.tr_io_output[51]:1	ACT #0	tcpwm0.g1.cnt6-	ACT #1
	peri.tr_io_output[71]:0	ACT #2	scb2.uart.tx	ACT #4
	scb2.spi.mosi	ACT #5	scb2.i2c.sda	ACT #7
	trace.data1	ACT #9	hppass.gpio_out1	ACT #12
	peri.tr_io_input[31]:0	ACT #14	peri.tr_io_output[31]:0	ACT #15
P7.2	peri.tr_io_output[52]:1	ACT #0	tcpwm0.g1.cnt7+	ACT #1
	peri.tr_io_output[72]:0	ACT #2	scb2.uart.rx	ACT #4
	scb2.spi.miso	ACT #5	trace.data2	ACT #9
	hppass.gpio_out2	ACT #12	peri.tr_io_input[32]:0	ACT #14
	peri.tr_io_output[32]:0	ACT #15		
P7.3	peri.tr_io_output[53]:1	ACT #0	tcpwm0.g1.cnt7-	ACT #1
	peri.tr_io_output[73]:0	ACT #2	scb2.uart.rts	ACT #4
	scb2.spi.select0	ACT #5	trace.data3	ACT #9
	hppass.gpio_out3	ACT #12	peri.tr_io_input[33]:0	ACT #14
	peri.tr_io_output[33]:0	ACT #15		
P7.4	peri.tr_io_output[54]:1	ACT #0	scb2.spi.select1	ACT #5
	trace.clock	ACT #9	hppass.gpio_out4	ACT #12
	peri.tr_io_input[34]:0	ACT #14	peri.tr_io_output[34]:0	ACT #15
P7.5	peri.tr_io_output[55]:1	ACT #0	scb2.spi.select2	ACT #5
	peri.tr_io_input[35]:0	ACT #14	peri.tr_io_output[35]:0	ACT #15
P7.6	peri.tr_io_output[56]:1	ACT #0	peri.tr_io_input[36]:0	ACT #14
	peri.tr_io_output[36]:0	ACT #15		
P7.7	peri.tr_io_output[57]:1	ACT #0	peri.tr_io_input[37]:0	ACT #14
	peri.tr_io_output[37]:0	ACT #15		

(table continues...)

Table 7 (continued) GPIO alternate functions and HSIOM routes

GPIO	Alternate functions and HSIOM routes			
P8.0	lpcomp0.in+	fixed	hppass.gpio_00_aio	fixed
	peri.tr_io_output[62]:2	ACT #1	tcpwm0.g2.cnt4+	ACT #2
	scb5.uart.cts	ACT #4	scb5.spi.select0	ACT #5
	trace.data0	ACT #9	hppass.gpio_out0	ACT #12
	peri.tr_io_input[38]:0	ACT #14	peri.tr_io_output[38]:0	ACT #15
	swj.trstn	DS #5		
P8.1	lpcomp0.in-	fixed	peri.tr_io_output[63]:2	ACT #1
	tcpwm0.g2.cnt4-	ACT #2	scb5.uart.rx	ACT #4
	scb5.spi.mosi	ACT #5	scb5.i2c.scl	ACT #7
	trace.data1	ACT #9	hppass.gpio_out1	ACT #12
	peri.tr_io_input[39]:0	ACT #14	peri.tr_io_output[39]:0	ACT #15
P8.2	lpcomp1.in+	fixed	hppass.gpio_01_aio	fixed
	peri.tr_io_output[64]:2	ACT #1	tcpwm0.g2.cnt5+	ACT #2
	can0.rx	ACT #3	scb5.uart.rts	ACT #4
	scb5.spi.miso	ACT #5	trace.data2	ACT #9
	hppass.gpio_out2	ACT #12	peri.tr_io_input[40]:0	ACT #14
	peri.tr_io_output[40]:0	ACT #15		
P8.3	lpcomp1.in-	fixed	peri.tr_io_output[65]:2	ACT #1
	tcpwm0.g2.cnt5-	ACT #2	can0.tx	ACT #3
	scb5.uart.tx	ACT #4	scb5.spi.clk	ACT #5
	scb5.i2c.sda	ACT #7	trace.data3	ACT #9
	hppass.gpio_out3	ACT #12	peri.tr_io_input[41]:0	ACT #14
	peri.tr_io_output[41]:0	ACT #15		
P8.4	scb5.spi.select1	ACT #5	peri.tr_io_input[42]:0	ACT #14
	peri.tr_io_output[42]:0	ACT #15		
P8.5	scb5.spi.select2	ACT #5	peri.tr_io_input[43]:0	ACT #14
	peri.tr_io_output[43]:0	ACT #15		
P9.0	hibernate_wakeup	fixed	smartio9.io0	fixed
	tcpwm0.g2.cnt6+	ACT #2	scb0.spi.clk	DS #1
	scb0.uart.cts	DS #2	scb0.i2c.scl	DS #3
	peri.tr_io_input[44]:0	ACT #14	peri.tr_io_output[44]:0	ACT #15

(table continues...)

Table 7 (continued) GPIO alternate functions and HSIOM routes

GPIO	Alternate functions and HSIOM routes			
P9.1	smartio9.io1	fixed	tcpwm0.g2.cnt6-	ACT #2
	scb0.spi.select0	DS #1	scb0.uart.rts	DS #2
	peri.tr_io_input[45]:0	ACT #14	peri.tr_io_output[45]:0	ACT #15
P9.2	smartio9.io2	fixed	tcpwm0.g2.cnt7+	ACT #2
	can0.rx	ACT #3	scb0.spi.mosi	DS #1
	scb0.uart.rx	DS #2	scb0.i2c.sda	DS #3
	trace.clock	ACT #9	hppass.gpio_out4	ACT #12
	peri.tr_io_input[46]:0	ACT #14	peri.tr_io_output[46]:0	ACT #15
P9.3	smartio9.io3	fixed	tcpwm0.g2.cnt7-	ACT #2
	can0.tx	ACT #3	scb0.spi.miso	DS #1
	scb0.uart.tx	DS #2	cpuss.clk_fm_pump	ACT #8
	cpuss.fault[0]:0	ACT #9	peri.tr_io_input[47]:0	ACT #14
	peri.tr_io_output[47]:0	ACT #15		
P9.4	smartio9.io4	fixed	scb0.spi.select1	DS #1
	peri.tr_io_input[48]:0	ACT #14	peri.tr_io_output[48]:0	ACT #15
P9.5	vext_ref_reg	fixed	smartio9.io5	fixed
	scb0.spi.select2	DS #1	peri.tr_io_input[49]:0	ACT #14
	peri.tr_io_output[49]:0	ACT #15		

Table 8 GPIO alternate functions

Function	GPIOs	Function	GPIOs	Function	GPIOs
cal_wave	P2.1	can0.rx	P8.2, P9.2	can0.tx	P8.3, P9.3
can1.rx	P5.2, P6.2	can1.tx	P5.3, P6.3	cpuss.clk_fm_pump	P9.3
cpuss.fault[0]:0	P9.3	cpuss.fault[0]:1	P6.3	eco_in	P1.0
eco_out	P1.1	ext_clk	P0.0, P2.2	hibernate_wakeup	P2.0, P9.0
hppass.gpio_00_aio	P8.0	hppass.gpio_01_aio	P8.2	hppass.gpio_out0	P7.0, P8.0
hppass.gpio_out1	P7.1, P8.1	hppass.gpio_out2	P7.2, P8.2	hppass.gpio_out3	P7.3, P8.3
hppass.gpio_out4	P7.4, P9.2	lpcomp0.in+	P8.0	lpcomp0.in-	P8.1
lpcomp1.in+	P8.2	lpcomp1.in-	P8.3	peri.tr_io_input[0]:0	P0.0
peri.tr_io_input[10]:0	P3.0	peri.tr_io_input[11]:0	P3.1	peri.tr_io_input[12]:0	P3.2

(table continues...)

Table 8 (continued) GPIO alternate functions

Function	GPIOs	Function	GPIOs	Function	GPIOs
peri.tr_io_input[13]:0	P3.3	peri.tr_io_input[14]:0	P4.0	peri.tr_io_input[15]:0	P4.1
peri.tr_io_input[16]:0	P4.2	peri.tr_io_input[17]:0	P4.3	peri.tr_io_input[18]:0	P4.4
peri.tr_io_input[19]:0	P4.5	peri.tr_io_input[20]:0	P0.1	peri.tr_io_input[21]:0	P4.6
peri.tr_io_input[22]:0	P4.7	peri.tr_io_input[23]:0	P5.0	peri.tr_io_input[24]:0	P5.1
peri.tr_io_input[25]:0	P5.2	peri.tr_io_input[26]:0	P5.3	peri.tr_io_input[27]:0	P6.0
peri.tr_io_input[28]:0	P6.1	peri.tr_io_input[29]:0	P6.2	peri.tr_io_input[30]:0	P6.3
peri.tr_io_input[31]:0	P1.0	peri.tr_io_input[32]:0	P7.0	peri.tr_io_input[33]:0	P7.1
peri.tr_io_input[34]:0	P7.2	peri.tr_io_input[35]:0	P7.3	peri.tr_io_input[36]:0	P7.4
peri.tr_io_input[37]:0	P7.5	peri.tr_io_input[38]:0	P7.6	peri.tr_io_input[39]:0	P7.7
peri.tr_io_input[40]:0	P8.0	peri.tr_io_input[41]:0	P8.1	peri.tr_io_input[42]:0	P1.1
peri.tr_io_input[43]:0	P8.2	peri.tr_io_input[44]:0	P8.3	peri.tr_io_input[45]:0	P8.4
peri.tr_io_input[46]:0	P8.5	peri.tr_io_input[47]:0	P9.0	peri.tr_io_input[48]:0	P9.1
peri.tr_io_input[49]:0	P9.2	peri.tr_io_input[50]:0	P9.3	peri.tr_io_input[51]:0	P9.4
peri.tr_io_input[52]:0	P9.5	peri.tr_io_input[53]:0	P1.2	peri.tr_io_input[54]:0	P1.3
peri.tr_io_input[55]:0	P2.0	peri.tr_io_input[56]:0	P2.1	peri.tr_io_input[57]:0	P2.2
peri.tr_io_input[58]:0	P2.3	peri.tr_io_output[59]:0	P0.0	peri.tr_io_output[60]:0	P3.0
peri.tr_io_output[61]:0	P3.1	peri.tr_io_output[62]:0	P3.2	peri.tr_io_output[63]:0	P3.3
peri.tr_io_output[64]:0	P4.0	peri.tr_io_output[65]:0	P4.1	peri.tr_io_output[66]:0	P4.2
peri.tr_io_output[67]:0	P4.3	peri.tr_io_output[68]:0	P4.4	peri.tr_io_output[69]:0	P4.5

(table continues...)

Table 8 (continued) GPIO alternate functions

Function	GPIOs	Function	GPIOs	Function	GPIOs
peri.tr_io_output[1]:0	P0.1	peri.tr_io_output[20]:0	P4.6	peri.tr_io_output[21]:0	P4.7
peri.tr_io_output[22]:0	P5.0	peri.tr_io_output[23]:0	P5.1	peri.tr_io_output[24]:0	P5.2
peri.tr_io_output[25]:0	P5.3	peri.tr_io_output[26]:0	P6.0	peri.tr_io_output[27]:0	P6.1
peri.tr_io_output[28]:0	P6.2	peri.tr_io_output[29]:0	P6.3	peri.tr_io_output[2]:0	P1.0
peri.tr_io_output[30]:0	P7.0	peri.tr_io_output[31]:0	P7.1	peri.tr_io_output[32]:0	P7.2
peri.tr_io_output[33]:0	P7.3	peri.tr_io_output[34]:0	P7.4	peri.tr_io_output[35]:0	P7.5
peri.tr_io_output[36]:0	P7.6	peri.tr_io_output[37]:0	P7.7	peri.tr_io_output[38]:0	P8.0
peri.tr_io_output[39]:0	P8.1	peri.tr_io_output[3]:0	P1.1	peri.tr_io_output[40]:0	P8.2
peri.tr_io_output[41]:0	P8.3	peri.tr_io_output[42]:0	P8.4	peri.tr_io_output[43]:0	P8.5
peri.tr_io_output[44]:0	P9.0	peri.tr_io_output[45]:0	P9.1	peri.tr_io_output[46]:0	P9.2
peri.tr_io_output[47]:0	P9.3	peri.tr_io_output[48]:0	P9.4	peri.tr_io_output[49]:0	P9.5
peri.tr_io_output[4]:0	P1.2	peri.tr_io_output[50]:0	P4.0	peri.tr_io_output[50]:1	P7.0
peri.tr_io_output[51]:0	P4.1	peri.tr_io_output[51]:1	P7.1	peri.tr_io_output[52]:0	P4.2
peri.tr_io_output[52]:1	P7.2	peri.tr_io_output[53]:0	P4.3	peri.tr_io_output[53]:1	P7.3
peri.tr_io_output[54]:0	P4.4	peri.tr_io_output[54]:1	P7.4	peri.tr_io_output[55]:0	P4.5
peri.tr_io_output[55]:1	P7.5	peri.tr_io_output[56]:0	P4.6	peri.tr_io_output[56]:1	P7.6
peri.tr_io_output[57]:0	P4.7	peri.tr_io_output[57]:1	P7.7	peri.tr_io_output[58]:0	P2.0
peri.tr_io_output[58]:1	P1.0	peri.tr_io_output[59]:0	P2.1	peri.tr_io_output[59]:1	P1.1
peri.tr_io_output[5]:0	P1.3	peri.tr_io_output[60]:0	P2.2	peri.tr_io_output[60]:1	P1.2

(table continues...)

Table 8 (continued) GPIO alternate functions

Function	GPIOs	Function	GPIOs	Function	GPIOs
peri.tr_io_output[61]:0	P2.3	peri.tr_io_output[61]:1	P1.3	peri.tr_io_output[62]:0	P3.0
peri.tr_io_output[62]:1	P5.0	peri.tr_io_output[62]:2	P8.0	peri.tr_io_output[63]:0	P3.1
peri.tr_io_output[63]:1	P5.1	peri.tr_io_output[63]:2	P8.1	peri.tr_io_output[64]:0	P3.2
peri.tr_io_output[64]:1	P5.2	peri.tr_io_output[64]:2	P8.2	peri.tr_io_output[65]:0	P3.3
peri.tr_io_output[65]:1	P5.3	peri.tr_io_output[65]:2	P8.3	peri.tr_io_output[66]:0	P6.0
peri.tr_io_output[67]:0	P6.1	peri.tr_io_output[68]:0	P6.2	peri.tr_io_output[69]:0	P6.3
peri.tr_io_output[6]:0	P2.0	peri.tr_io_output[70]:0	P7.0	peri.tr_io_output[70]:1	P1.0
peri.tr_io_output[71]:0	P7.1	peri.tr_io_output[71]:1	P1.1	peri.tr_io_output[72]:0	P7.2
peri.tr_io_output[72]:1	P1.2	peri.tr_io_output[73]:0	P7.3	peri.tr_io_output[73]:1	P1.3
peri.tr_io_output[7]:0	P2.1	peri.tr_io_output[8]:0	P2.2	peri.tr_io_output[9]:0	P2.3
scb0.i2c.scl	P9.0	scb0.i2c.sda	P9.2	scb0.spi.clk	P9.0
scb0.spi.miso	P9.3	scb0.spi.mosi	P9.2	scb0.spi.select0	P9.1
scb0.spi.select1	P9.4	scb0.spi.select2	P9.5	scb0.uart.cts	P9.0
scb0.uart.rts	P9.1	scb0.uart.rx	P9.2	scb0.uart.tx	P9.3
scb1.i2c.scl	P1.3, P2.1	scb1.i2c.sda	P1.2, P2.2	scb1.spi.clk	P1.1, P2.1
scb1.spi.miso	P1.3, P2.3	scb1.spi.mosi	P1.2, P2.2	scb1.spi.select0	P1.0, P2.0
scb1.uart.cts	P1.0, P2.0	scb1.uart.rts	P1.1, P2.1	scb1.uart.rx	P1.2, P2.2
scb1.uart.tx	P1.3, P2.3	scb2.i2c.scl	P7.0	scb2.i2c.sda	P7.1
scb2.spi.clk	P7.0	scb2.spi.miso	P7.2	scb2.spi.mosi	P7.1
scb2.spi.select0	P7.3	scb2.spi.select1	P7.4	scb2.spi.select2	P7.5
scb2.uart.cts	P7.0	scb2.uart.rts	P7.3	scb2.uart.rx	P7.2
scb2.uart.tx	P7.1	scb3.i2c.scl	P5.1, P6.1	scb3.i2c.sda	P5.0, P6.0
scb3.spi.clk	P5.2, P6.2	scb3.spi.miso	P5.1, P6.1	scb3.spi.mosi	P5.0, P6.0
scb3.spi.select0	P5.3, P6.3	scb3.uart.cts	P5.0, P6.0	scb3.uart.rts	P5.1, P6.1
scb3.uart.rx	P5.2, P6.2	scb3.uart.tx	P5.3, P6.3	scb4.i2c.scl	P3.2, P4.2
scb4.i2c.sda	P3.1, P4.1	scb4.spi.clk	P3.2, P4.2	scb4.spi.miso	P3.1, P4.1

(table continues...)

Table 8 (continued) GPIO alternate functions

Function	GPIOs	Function	GPIOs	Function	GPIOs
scb4.spi.mosi	P3.0, P4.0	scb4.spi.select0	P3.3, P4.3	scb4.uart.cts	P3.0, P4.0
scb4.uart.rts	P3.1, P4.1	scb4.uart.rx	P3.2, P4.2	scb4.uart.tx	P3.3, P4.3
scb5.i2c.scl	P8.1	scb5.i2c.sda	P8.3	scb5.spi.clk	P8.3
scb5.spi.miso	P8.2	scb5.spi.mosi	P8.1	scb5.spi.select0	P8.0
scb5.spi.select1	P8.4	scb5.spi.select2	P8.5	scb5.uart.cts	P8.0
scb5.uart.rts	P8.2	scb5.uart.rx	P8.1	scb5.uart.tx	P8.3
smartio0.io0	P0.0	smartio0.io1	P0.1	smartio1.io0	P1.0
smartio1.io1	P1.1	smartio1.io2	P1.2	smartio1.io3	P1.3
smartio2.io0	P2.0	smartio2.io1	P2.1	smartio2.io2	P2.2
smartio2.io3	P2.3	smartio3.io0	P3.0	smartio3.io1	P3.1
smartio3.io2	P3.2	smartio3.io3	P3.3	smartio5.io0	P5.0
smartio5.io1	P5.1	smartio5.io2	P5.2	smartio5.io3	P5.3
smartio6.io0	P6.0	smartio6.io1	P6.1	smartio6.io2	P6.2
smartio6.io3	P6.3	smartio9.io0	P9.0	smartio9.io1	P9.1
smartio9.io2	P9.2	smartio9.io3	P9.3	smartio9.io4	P9.4
smartio9.io5	P9.5	swj.swclk/tclk	P1.2	swj.swdio/tms	P1.3
swj.tdi	P2.0	swj.tdo	P2.1	swj.trstn	P8.0
tcpwm0.g1.cnt4+	P4.0, P6.0	tcpwm0.g1.cnt4-	P4.1, P6.1	tcpwm0.g1.cnt5+	P4.2, P6.2
tcpwm0.g1.cnt5-	P4.3, P6.3	tcpwm0.g1.cnt6+	P4.4, P7.0	tcpwm0.g1.cnt6-	P4.5, P7.1
tcpwm0.g1.cnt7+	P4.6, P7.2	tcpwm0.g1.cnt7-	P4.7, P7.3	tcpwm0.g2.cnt4+	P8.0
tcpwm0.g2.cnt4-	P8.1	tcpwm0.g2.cnt5+	P8.2	tcpwm0.g2.cnt5-	P8.3
tcpwm0.g2.cnt6+	P2.0, P9.0	tcpwm0.g2.cnt6-	P2.1, P9.1	tcpwm0.g2.cnt7+	P2.2, P9.2
tcpwm0.g2.cnt7-	P2.3, P9.3	trace.clock	P7.4, P9.2	trace.data0	P7.0, P8.0
trace.data1	P7.1, P8.1	trace.data2	P7.2, P8.2	trace.data3	P7.3, P8.3
vext_ref_reg	P9.5	wco_in	P0.1	wco_out	P0.0

The peri.tr_io_input[n] and peri.tr_io_output[n] provide one more level of trigger and signal routing option between the peripherals and the GPIO pins using the high-speed I/O matrix (HSIOM). The peri.tr_io_input[n] allows a GPIO pin to be used as peripheral trigger input source (external trigger). Similarly, the peri.tr_io_output[n] can be used to route peripheral triggers and some signals like TCPWM line_out and line_compl_out to a GPIO pin. For more information refer to the Trigger MUX connection tables in section 10.3 of the PSOC™ Control C3 architecture reference manual.

Note: SCB4 and SCB5 are not available in 48-pin devices

7 Electrical specifications

7.1 Absolute maximum ratings

Table 9 Absolute maximum ratings

Spec ID	Parameter	Symbol	Values			Unit	Note or test condition
			Min.	Typ.	Max.		
SID1	Analog or Digital Supply relative to Vss (Vssd=Vssa)	VDD_ABS	-0.5	-	4	V	Absolute Maximum
SID2	Direct digital core voltage input relative to Vssd	VCCD_ABS	-0.5	-	1.2	V	Absolute Maximum
SID3	GPIO voltage ; VDDD or VDDA	VGPI0_ABS	-0.5	-	VDD+0.5	V	Absolute Maximum
SID4	Current per GPIO	IGPI0_ABS	-25	-	25	mA	Absolute Maximum
SID5	GPIO injection current per pin	IGPI0_injection	-0.5	-	0.5	mA	Absolute Maximum
SID3A	Electrostatic discharge Human Body Model	ESD_HBM	2000	-	-	V	Absolute Maximum
SID4A	Electrostatic discharge Charged Device Model	ESD_CDM	500	-	-	V	Absolute Maximum
SID5A	Pin current for latchup free operation	LU	-100	-	100	mA	Absolute Maximum
SIDWA8	Maximum undershoot voltage for I/O	Vundershoot	-	-	-0.5	V	Duration not to exceed 25% of the duty cycle
SIDWA9	Maximum overshoot voltage for I/O	Vovershoot	-	-	VDDIO + 0.5	V	Duration not to exceed 25% of the duty cycle
SIDWA10	Maximum junction temperature	Tj	-	-	125	°C	

7.2 Device level specifications

7.2.1 Power supplies

Table 10 Power supplies

Spec ID	Parameter	Symbol	Values			Unit	Note or test condition
			Min.	Typ.	Max.		
SID6	Internal Regulator	VDDD	1.71	-	3.6	V	
SID7B	GPIO Supply for Ports 1, 2, 3, 4, 5, 6, 7	VDDIO_0	1.71	-	3.6	V	
SID7EP	E-Fuse Programming time	EFUSETIME	-	-	5.5	µs	Switch on time of 0.5µs included

(table continues...)

Table 10 (continued) Power supplies

Spec ID	Parameter	Symbol	Values			Unit	Note or test condition
			Min.	Typ.	Max.		
SID7C	GPIO Supply for Ports 8 and 9	VDDIO_1	1.71	-	3.6	V	
SID7A	Analog power supply for ADC and Comparator	VDDA	1.71	-	3.6	V	
SID6B	Backup Power; normally shorted to VDDD (supply PORT 0)	VBACKUP	1.71	-	3.6	V	Min. is 1.4 V in Backup mode
SID8	Output voltage (for core logic bypass)	VCCD (OD)	-	1.2	-	V	Over drive mode
SID8A	Output voltage (for core logic bypass)	VCCD (LP)	-	1.1	-	V	High-speed mode
SID8B	Output voltage (for core logic bypass)	VCCD (MF)	-	1	-		ULP mode. Valid for -20 to 125°C.
SID8C	Output voltage (for core logic bypass)	VCCD (ULP)	-	0.9	-		ULP mode. Valid for -20 to 125°C.
SID10	External Regulator voltage (VCCD) bypass	CEFC	3.76	4.7	5.6	μF	X5R ceramic or better. Value for 0.8 to 1.1 V.
SID11	Power supply decoupling capacitor	CEXC	-	10	-	μF	X5R ceramic or better

Deep Sleep Mode

SIDDS1	With internal LDO enabled and no SRAM retention	IDD33	-	6	8	μA	Max value is at 85°C (not including analog leakage on VDDA and VAREF_EXT)
SIDDS1_A	With internal LDO enabled and 64K SRAM retention	IDD33A	-	7	11	μA	Max value is at 85°C (not including analog leakage on VDDA and VAREF_EXT)

Hibernate Mode

SIDHIB1	VDDD = 1.8 V	IDD34	-	300	-	nA	No clocks running (not including analog leakage on VDDA and VAREF_EXT)
SIDHIB2	VDDD = 3.3 V	IDD34A	-	500	-	nA	No clocks running (not including analog leakage on VDDA and VAREF_EXT)

(table continues...)

Table 10 (continued) Power supplies

Spec ID	Parameter	Symbol	Values			Unit	Note or test condition
			Min.	Typ.	Max.		
SIDHIB3	VDDD = 1.8 V	IDD35	-	800	-	nA	WCO is running, lpcomp active (not including analog leakage on VDDA and VAREF_EXT)
SIDHIB4	VDDD = 3.3 V	IDD35A	-	1000	-	nA	WCO is running, lpcomp active (not including analog leakage on VDDA and VAREF_EXT)
SIDHIB5	Leakage on analog supply and analog reference in hibernate mode	IDDA	-	100	-	nA	Typical silicon and typical temperature

7.2.2 CPU currents and transition times

Table 11 CPU current and transition times

Spec ID	Parameter	Symbol	Values			Unit	Note or test condition
			Min.	Typ.	Max.		
Cortex® M33. Active Mode							
SIDC2	Execute from Cache;CM33 Active 180 MHz. PLL. Dhrystone. OD mode	IDD4	-	25	45	mA	VDDD=3.3 V, Max at 125°C
SIDC2A	Execute from Cache;CM33 Active 180 MHz. PLL. Dhrystone. OD mode	IDD4A	-	25	45	mA	VDDD=1.8 V, Max at 125°C
SIDC3	Execute from Cache;CM33 Active 150 MHz. PLL. Dhrystone. LP Mode	IDD5	-	18	35	mA	VDDD=3.3 V, Max at 125°C
SIDC3A	Execute from Cache;CM33 Active 150 MHz. PLL. Dhrystone. LP Mode	IDD5A	-	18	35	mA	VDDD=1.8 V, Max at 125°C
SIDC4	Execute from Cache;CM33 Active 70 MHz. PLL. Dhrystone. MF Mode	IDD6	-	12	27	mA	VDDD=3.3 V, Max at 125°C
SIDC4A	Execute from Cache;CM33 Active 70 MHz. PLL. Dhrystone. MF Mode	IDD6A	-	12	27	mA	VDDD=1.8 V, Max at 125°C
SIDC5	Execute from Cache;CM33 Active 50 MHz. PLL. Dhrystone. ULP Mode	IDD7	-	7	18	mA	VDDD=3.3 V, Max at 125°C

(table continues...)

Table 11 (continued) CPU current and transition times

Spec ID	Parameter	Symbol	Values			Unit	Note or test condition
			Min.	Typ.	Max.		
SIDC5A	Execute from Cache;CM33 Active 50 MHz. PLL. Dhrystone. ULP Mode	IDD7A	-	7	18	mA	VDDD=1.8 V, Max at 125°C

Cortex® M33 Sleep Mode

SIDS1	CM33 Sleep 180 MHz. PLL. OD Mode	IDD11	-	10	15	mA	VDDD=3.3 V, Max at 105°C
SIDS1A	CM33 Sleep 180 MHz. PLL. OD Mode	IDD11A	-	10	15	mA	VDDD=1.8 V, Max at 105°C
SIDS2	CM33 Sleep 150 MHz. PLL. LP Mode	IDD12	-	7	11	mA	VDDD=3.3 V, Max at 105°C
SIDS2A	CM33 Sleep 150 MHz. PLL. LP Mode	IDD12A	-	7.0	11	mA	VDDD=1.8 V, Max at 105°C
SIDS3	CM33 Sleep 70 MHz. PLL. MF Mode	IDD13	-	4.5	10	mA	VDDD=3.3 V, Max at 105°C
SIDS3A	CM33 Sleep 70 MHz. PLL. MF Mode	IDD13A	-	4.5	10	mA	VDDD=1.8 V, Max at 105°C
SIDS4	CM33 Sleep 50 MHz. PLL. ULP Mode	IDD14	-	4	9	mA	VDDD=3.3 V, Max at 105°C
SIDS4A	CM33 Sleep 50 MHz. PLL. ULP Mode	IDD14A	-	4	9	mA	VDDD=1.8 V, Max at 105°C

Boot Time

SIDBT1	Boot time after reset	BTIME	-	-	3000000	cycles	Refer to CPU clock cycles
--------	-----------------------	-------	---	---	---------	--------	---------------------------

Power Mode Transition Times

SID13A	Deep Sleep to Active transition time.	TDS_ACT	-	-	45	µs	DS to Active with 1.1 V operation
SID13B	Deep Sleep to Active LP transition time	TDS_ACTLP	-	-	26	µs	DS to Active LP with 1.0 V operation
SID13C	Deep Sleep-RAM to Active transition time	TDSR_ACT	-	-	800	µs	DS to Active with 1.1 V operation
SID13D	Deep Sleep-RAM to Active LP transition time	TDSR_ACTULP	-	-	800	µs	DS-RAM to Active LP with 1.0 V operation
SID14	Hibernate to Active transition time	THIB_ACT	-	2000	-	µs	Including PLL lock time

7.2.3 XRES

Table 12 XRES

Spec ID	Parameter	Symbol	Values			Unit	Note or test condition
			Min.	Typ.	Max.		

XRES AC Specifications

SID15	POR or XRES release to Active transition time	TXRES_ACT	-	2	-	mS	With BOOT_OD_CLOCK=180MHz, LISTEN_WINDOW=9 and BOOT_SIMPLE_APP configuration
SID16	XRES Pulse width	TXRES_PW	5	-	-	µS	

XRES DC Specifications

SID17	IDD when XRES asserted	TXRES_IDD	-	180	-	nA	VDDD = 1.8 V
SID17	IDD when XRES asserted	TXRES_IDD_1	-	330	-	nA	VDDD = 3.3 V
SID77	Input Voltage high threshold	VIH	0.7*VDD	-	-	V	CMOS Input
SID78	Input Voltage low threshold	VIL	-	-	0.3*VDD	V	CMOS Input
SID80	Input Capacitance	CIN	-	3	-	pF	XRES resistor removed
SID81	Input voltage hysteresis	VHYSXRES	-	100	-	mV	
SID82	Current through protection diode to VDD/Vss	IDIODE	-	-	100	µA	

7.2.4 GPIO

Table 13 GPIO

Spec ID	Parameter	Symbol	Values			Unit	Note or test condition
			Min.	Typ.	Max.		

GPIO DC Specifications

SID57	Input Voltage high threshold	VIH	0.7*VDD	-	-	V	CMOS Input
SID58	Input Voltage low threshold	VIL	-	-	0.3*VDD	V	CMOS Input
SID243	LVTTL input, VDD >= 2.7 V	VIH	2.0	-	-	V	
SID244	LVTTL input, VDD >= 2.7 V	VIL	-	-	0.8	V	
SID59	Output Voltage high level	VOH	VDD-0.5	-	-	V	Ioh = 6 mA
SID62A	Output Voltage low level	VOL	-	-	0.4	V	Iol = 6 mA
SID63	Pull-up resistor	RPULLUP	3.5	5.6	8.5	kΩ	
SID64	Pull-down resistor	RPULLDOWN	3.5	5.6	8.5	kΩ	
SID65	Input leakage current(absolute value)	IIL	-	-	2	nA	25°C, VDD = 3.0 V
SID66	Input Capacitance	CIN	-	-	5	pF	

(table continues...)

Table 13 (continued) GPIO

Spec ID	Parameter	Symbol	Values			Unit	Note or test condition
			Min.	Typ.	Max.		
SID67	Input hysteresis LVTTTL VDD > 2.7 V	VHYSTTL	100	0	-	mV	
SID68	Input hysteresis CMOS	VHYSCMOS	0.05*VDD	-	-	mV	
SID69	Current through protection diode to VDD/VSS	IDIODE	-	-	100	µA	
SID69A	Maximum Total Source or Sink Chip Current	ITOT_GPIO	-	-	200	mA	

GPIO AC Specifications

SID70	Rise time in Fast Strong Mode. 10% to 90% of VDD	TRISEF	-	-	2.5	ns	Load = 15 pF, 8 mA drive strength
SID71	Fall time in Fast Strong Mode. 10% to 90% of VDD.	TFALLF	-	-	2.5	ns	Load = 15 pF, 8 mA drive strength
SID72	Rise time in Slow Strong Mode. 10% to 90% of VDD	TRISES_1	-	-	14.4	ns	Load = 15 pF, 8 mA drive strength, VDD ≤ 2.7 V
SID72A	Rise time in Slow Strong Mode. 10% to 90% of VDD	TRISES_2	-	-	7.2	ns	Load = 15 pF, 8 mA drive strength, 2.7 V < VDD ≤ 3.6
SID73	Fall time in Slow Strong Mode. 10% to 90% of VDD	TFALLS_1	-	-	14.4	ns	Load = 15 pF, 8 mA drive strength, VDD ≤ 2.7 V
SID73A	Fall time in Slow Strong Mode. 10% to 90% of VDD	TFALLS_2	-	-	7.2	ns	Load = 15 pF, 8 mA drive strength, 2.7 V < VDD ≤ 3.6
SID73G	Fall time (30% to 70% of VDD) in Slow Strong mode	TFALL_I2C	20*Vddi o/5.5	-	250	ns	Load = 10 pF to 400 pF, 8 mA drive strength
SID74	GPIO Fout. Fast Strong mode.	FGPIOUT1	-	-	80	MHz	90/10%, 15 pF load, 60/40 duty cycle
SID75	GPIO Fout; Slow Strong mode.	FGPIOUT2	-	-	16.7	MHz	90/10%, 15 pF load, 60/40 duty cycle
SID76	GPIO Fout; Fast Strong mode.	FGPIOUT3	-	-	7	MHz	90/10%, 25 pF load, 60/40 duty cycle
SID245	GPIO Fout; Slow Strong mode.	FGPIOUT4	-	-	3.5	MHz	90/10%, 25 pF load, 60/40 duty cycle

(table continues...)

Table 13 (continued) GPIO

Spec ID	Parameter	Symbol	Values			Unit	Note or test condition
			Min.	Typ.	Max.		
SID246	GPIO input operating frequency; 1.71 V ≤ VDD ≤ 3.6 V	FGPIOIN	-	-	100	MHz	90/10% Vio

7.3 Analog peripherals

Table 14 Analog subsystem

Spec ID	Parameter	Symbol	Values			Unit	Note or test condition
			Min.	Typ.	Max.		

Analog Peripherals

SIDAS1	Leakage on single analog input pin	AIN_LEAK	-	0.32	12	nA	Maximum leakage at 125°C
SIDAS2	Input Capacitance of CSG	AIN_CAP_CSG	-	-	1	pF	Valid for VDDA ≥ 2.7 V
SIDAS2A	Input Capacitance of ADC	AIN_CAP_ADC	-	-	3	pF	Valid for VDDA ≥ 2.7 V
SIDAS3	Total series resistance on channel reaching CSG	AIN_RES_CSGS	-	-	500	Ω	Valid for VDDA ≥ 2.7 V
SIDAS3A	Total parallel resistance on channel reaching CSG	AIN_RES_CSGP	-	-	400	MΩ	Valid for VDDA ≥ 2.7 V
SIDAS4	Total resistance of analog channel directly connected to S/H	AIN_RES_ADC	-	-	750	Ω	Valid for VDDA ≥ 2.7 V
SIDAS4A	Total resistance of analog channel connected to S/H through AMUX	AIN_RES_ADC	-	-	2600	Ω	Valid for VDDA ≥ 2.7 V

7.3.1 LP comparator

Table 15 LPComp

Spec ID	Parameter	Symbol	Values			Unit	Note or test condition
			Min.	Typ.	Max.		

LP Comparator DC Specifications

SID84	Input offset voltage for COMP1. Normal power mode.	VOFFSET1	-10	-	10	mV	
SID85A	Input offset voltage. Low-power mode.	VOFFSET2	-25	+/-12	25	mV	
SID85B	Input offset voltage. Ultra low-power mode.	VOFFSET3	-25	+/-12	25	mV	
SID86	Hysteresis when enabled in Normal mode	VHYST1	-	-	60	mV	

(table continues...)

Table 15 (continued) LPComp

Spec ID	Parameter	Symbol	Values			Unit	Note or test condition
			Min.	Typ.	Max.		
SID86A	Hysteresis when enabled in Low-power mode	VHYST2	-	-	80	mV	
SID87	Input common mode voltage in Normal mode	VICM1	0	-	VDDIO1 -0.1	V	
SID247	Input common mode voltage in Low power mode	VICM2	0	-	VDDIO1 -0.1	V	
SID247A	Input common mode voltage in Ultra low power mode	VICM3	0	-	VDDIO1 -0.1	V	
SID88	Common mode rejection ratio in Normal power mode	CMRR	50	-	-	dB	
SID89	Block Current, Normal mode	ICMP1	-	-	150	μA	
SID248	Block Current, Low power mode	ICMP2	-	-	10	μA	
SID259	Block Current in Ultra low-power mode	ICMP3	-	0.3	0.85	μA	
SID90	DC Input impedance of comparator	ZCMP	35	-	-	MΩ	

LP Comparator AC Specifications

SID91	Response time, Normal mode, 100 mV overdrive	TRESP1	-	-	100	ns	
SID258	Response time, Low power mode, 100 mV overdrive	TRESP2	-	-	1000	ns	
SID92	Response time, Ultra-low power mode, 100 mV overdrive	TRESP3	-	-	20	μs	
SID92E	Time from Enabling to operation	T_CMP_EN1	-	-	10	μs	Normal and Low-power modes. Guaranteed by design
SID92F	Time from Enabling to operation	T_CMP_EN2	-	-	50	μs	Ultra low-power mode. Guaranteed by design

7.3.2 HPPASS

Table 16 HPPASS

Spec ID	Parameter	Symbol	Values			Unit	Note or test condition
			Min.	Typ.	Max.		

CSG DC Specifications

SIDCSG	Reference voltage for DAC	DAC_REF	-	VDDA	-	V	Supply is used as reference for the DAC
SIDCSG.0	Input referred residual offset for comparator	VOFFSET	-3	-	3	mV	

(table continues...)

Table 16 (continued) HPPASS

Spec ID	Parameter	Symbol	Values			Unit	Note or test condition
			Min.	Typ.	Max.		
SIDCSG.1	Input common mode voltage	VCMR	0.2	-	VDDA-0.2	V	
SIDCSG.2	Operating current on VDDA at 120 MHz	IVDDA	-	-	700	uA	Includes comparator, DAC on VDDA and all internal blocks. Only one instance of CSG
SIDCSG.2A	Operating current(Single instance) on VCCD at 120 MHz	IVCCD	-	-	50	uA	Substraction is done to measure the consumption of one CSG slice
SIDCSG.3	minimum overdrive voltage at 10 MHz	OD10M	12	-	-	mV	
SIDCSG.3A	minimum overdrive voltage at 120 MHz	OD120M	100	-	-	mV	
SIDCSG.3 B	minimum overdrive voltage at 80 MHz	OD80M	50	-	-	mV	
SIDCSG.4	DAC INL	INL	-1	-	2	LSB	Referred to 10-bit DAC with full scale LSB at 3.3 V
SIDCSG.5	DAC DNL	DNL	-1	-	1	LSB	Referred to 10-bit DAC with full scale LSB at 3.3 V

CSG AC Specifications

SIDCSG.7	Comparatror Input referred comparator noise	INPNOISE	-	-	400	uV	
SIDCSG.8	Dac settling within +-1LSB for > = 256 LSB change	DACSET	-	-	33	ns	Up to 1023 LSB code change
SIDCSG.8A	Dac settling within +-1LSB for <= 255 LSB change	DACSETA	-	-	25	ns	LSB code change of 64 and above(Less than 64 and upto 4 LSB code change is guranteed by design)

(table continues...)

Table 16 (continued) HPPASS

Spec ID	Parameter	Symbol	Values			Unit	Note or test condition
			Min.	Typ.	Max.		
SIDCSG.9	DAC Observability Error by the ADC (CSG accuracy and operation not affected)	DAC_OBSERR	-	-	16	LSB	LSB refers to the 10-bit DAC. Maximum error condition when $ V_{IN}-V_{DAC} = V_{DDA}$
			-	-	8	LSB	LSB refers to the 10-bit DAC. Maximum error condition when $ V_{IN}-V_{DAC} = V_{DDA}/2$
			-	-	4	LSB	LSB refers to the 10-bit DAC. Maximum error condition when $ V_{IN}-V_{DAC} = V_{DDA}/4$

Temperature Sensor Specifications

SID93	Temperature sensor accuracy	TSENSACC	-5	±1	5	°C	-40 to +125 C
-------	-----------------------------	----------	----	----	---	----	---------------

Internal Reference Specifications

SID93R		VREFBG	1188	1.2	1212	V	
--------	--	--------	------	-----	------	---	--

12-bit SAR ADC DC Specifications

SIDADC	External Reference	VAREF_EXT	-	VDDA	-	V	For meeting the parameters of the ADC, it is recommended to connect reference to VAREF
SIDADC.0	SAR ADC Resolution	RES	-	-	12	bits	
SIDADC.1	Number of Sample and Hold stages - single ended	SH_S	-	-	16		
SIDADC.2	Gain Error without calibration	GAINERR_NO CAL	-5	-	5	%	LSB referred to VAREF = 3.3 V
SIDADC.3	Gain error at gain =1 after calibration	GAINERR_1	-0.1	-	0.1	%	LSB referred to VAREF = 3.3 V
SIDADC.3A	Gain error at gain =3 after calibration	GAINERR_3	-0.3	-	0.3	%	LSB referred to VAREF = 3.3 V
SIDADC.3 B	Gain error at gain =6 after calibration	GAINERR_6	-0.6	-	0.6	%	LSB referred to VAREF = 3.3 V
SIDADC.3 C	Gain error at gain =12 after calibration	GAINERR_12	-1.2	-	1.2	%	LSB referred to VAREF = 3.3 V
SIDADC.4	Offset Error without calibration	OFFSETERR_NO CAL	-10	-	10	mV	

(table continues...)

Table 16 (continued) HPPASS

Spec ID	Parameter	Symbol	Values			Unit	Note or test condition
			Min.	Typ.	Max.		
SIDADC.4A	Offset Error after calibration	OFFSETERR	-1.5	-	1.5	mV	
SIDADC.5A	Total unadjusted error for gain =1	TUE_G1	-4.5	-	4.5	LSB	Gain =1, LSB referred to VAREF = 3.3 V
SIDADC.5 B	Total unadjusted error for gain =3	TUE_G3	-4.5	-	4.5	LSB	Gain =3, LSB referred to VAREF = 3.3 V
SIDADC.5 C	Total unadjusted error for gain =6	TUE_G6	-4.5	-	4.5	LSB	Gain =6, LSB referred to VAREF = 3.3 V
SIDADC.5 D	Total unadjusted error for gain =12	TUE_G12	-4.5	-	4.5	LSB	Gain =12, LSB referred to VAREF = 3.3 V
SIDADC.6	Integral Non Linearity.	A_INL	-2	-	2	LSB	VAREF = 3.3 V
SIDADC.7	Differential Non Linearity.	A_DNL	-1	-	2	LSB	VAREF = 3.3 V
SIDADC.8	Current consumption	A_ISAR_1	-	-	13	mA	Current consumption on analog supply VDDA, VDDA = 3.3 V
SIDADC.9	Input voltage range	A_VINS	Vss	-	VDDA	V	When VDDA > VAREF_EXT, ADC result will saturate when VIN = VAREF_EXT

12-bit SAR ADC AC Specifications

SIDADC.9A	Analog Input voltage transient tolerated	A_VINSTRAN	-	-	VDDA + 1.5	V	Input current ≤ 3 mA. Valid for max VDDA = 3.3 V. Slew rate for VIN from VDDA to VDDA+1.5 ≥ 7 us.
SIDADC.10	ADC frequency	fADC	120	-	240	MHz	Operating voltage mode, OD = 1.2 V, max when VDDA > = 2.7 V, min when VDDA < 2.7 V
SIDADC.12	RMS noise	A_RMS	-	-	1.5	LSB	1 sigma value

(table continues...)

Table 16 (continued) HPPASS

Spec ID	Parameter	Symbol	Values			Unit	Note or test condition
			Min.	Typ.	Max.		
SIDADC.13	Interchannel crosstalk with <=6 samplers	CROSSTALK_5	-4	-	4	LSB	Inter Channel Crosstalk for VAREF = 3.3 V with < = 6 samplers ending sampling simultaneously. After crosstalk compensation by software routine.
SIDADC.13 A	Interchannel crosstalk with <=11 samplers	CROSSTALK_10	-7	-	7	LSB	Inter Channel Crosstalk for VAREF = 3.3 V with < = 11 samplers ending sampling simultaneously. After crosstalk compensation by software routine.
SIDADC.13 B	Interchannel crosstalk with <=16 samplers	CROSSTALK_15	-10	-	10	LSB	Inter Channel Crosstalk for VAREF = 3.3 V with < = 16 samplers ending sampling simultaneously. After crosstalk compensation by software routine.
SIDADC.14	Sample rate	A_SAMP_1	-	-	12	MspS	VDDA 2.7 - 3.6 (this includes minimum sampling time and conversion time) . fADC max = 240 MHz
SIDADC.15	Sample rate	A_SAMP_2	-	-	6	MspS	VDDA 1.7 - 2.7 (this includes minimum sampling time and conversion time). fADC max = 120 MHz
SIDADC.16	Signal-to-noise and Distortion ratio (SINAD).	A_SINAD	65	-	-	dB	Fin = 10 kHz, Gain = 1, VAREF = 3.3 V
SIDADC.17	Start Up time after stable supply	T_STARTUP	-	-	1300	cycles	ADC clock frequency define the start up time

(table continues...)

Table 16 (continued) HPPASS

Spec ID	Parameter	Symbol	Values			Unit	Note or test condition
			Min.	Typ.	Max.		
SIDADC.18	Maximum calibration time	T_CAL	-	-	2160000	Cycles	ADC clock frequency define the Calibration time. Calibration is required only after power up. After Start up calibration values will be loaded into the ADC calibration registers. Use can decide to skip the power up calibration. Calibration values are not retained when the MCU goes from Active to Deep Sleep and Hibernate mode.
SIDADC.19	Minimum sampling time for analog input through analog pad direct connection to S/H	T_SAMPLE	4	-	-	cycles	Referred to fADC
SIDADC.19 B	Minimum sampling time for analog input through analog pad connected to S/H via AROUTE (AMUX)	T_SAMPLE_AROUTE	20	-	-	cycles	Referred to fADC
SIDADC.19 C	Minimum sampling time for analog input through GPIO or ADFT connected to S/H via AROUTE (AMUX)	T_SAMPLE_GPIO	40	-	-	cycles	Referred to fADC

7.4 Digital peripherals

7.4.1 HRPWM specification

Table 17 HRPWM specifications

Spec ID	Parameter	Symbol	Values			Unit	Note or test condition
			Min.	Typ.	Max.		
SIDHRPW M.1	HRPWM Resolution	HR_RES	-	(1)/ (Fc*64)	-	ps	Max Fc = 240 MHz, resulting in typical resolution = 65.1 ps. When HRPWM feature is enabled, prescaler is not allowed to be used in PERI as well as in TCPWM Counter

7.4.2 TCPWM specifications

Table 18 TCPWM specifications

Spec ID	Parameter	Symbol	Values			Unit	Note or test condition
			Min.	Typ.	Max.		

Digital Peripherals

SID.TCPW M.2B	Block current consumption at 100 MHz	ITCPWM4	-	-	1600	µA	PWM_DT mode and HRPWM mode enabled with 50% duty cycle
SID.TCPW M.2C	Block current consumption at 240 MHz	ITCPWM4	-	-	3600	µA	PWM_DT mode and HRPWM mode enabled with 50% duty cycle
SID.TCPW M.3	Operating frequency	TCPWMFREQ	-	-	240	MHz	Fc max = 240 MHz
SID.TCPW M.4	Input Trigger Pulse Width for all Trigger Events	TPWMENEXT	2/Fc	-	-	ns	Trigger Events can be Stop, Start, Reload, Count, Capture, or Kill depending on which mode of operation is selected.

(table continues...)

Table 18 (continued) TCPWM specifications

Spec ID	Parameter	Symbol	Values			Unit	Note or test condition
			Min.	Typ.	Max.		
SID.TCPW M.5	Output Trigger Pulse widths	TPWMEXT	1.5/Fc	-	-	ns	Minimum possible width of Overflow, Underflow, and CC (Counter equals Compare value) trigger outputs
SID.TCPW M.5A	Resolution of Counter	TCRES	1/Fc	-	-	ns	Minimum time between successive counts at VDDD = 3.3 V
SID.TCPW M.5B	PWM Resolution	PWMRES	1/Fc	-	-	ns	Minimum pulse width of PWM Output at VDDD = 3.3 V

7.4.3 SCB

Table 19 SCB

Spec ID	Parameter	Symbol	Values			Unit	Note or test condition
			Min.	Typ.	Max.		

Fixed I2C DC Specifications

SID149	Block current consumption at 100 KHz	I2C1	-	-	30	μA	
SID150	Block current consumption at 400 KHz	I2C2	-	-	80	μA	
SID151	Block current consumption at 1 Mbps	I2C3	-	-	180	μA	
SID152	I2C enabled in Deep Sleep mode	I2C4	-	-	1.7	μA	At 60°C

Fixed I2C AC Specifications

SID153	Bit Rate	FI2C1	-	-	1	Mbps	
--------	----------	-------	---	---	---	------	--

Fixed UART DC Specifications

SID160	Block current consumption at 100 Kbits/sec	IUART1	-	-	30	μA	
SID161	Block current consumption at 1000 Kbits/sec	IUART2	-	-	180	μA	

Fixed UART AC Specifications

SID162A	Bit Rate	FUART1	-	-	3	Mbps	ULP Mode
SID162B	Bit Rate	FUART2	-	-	8	Mbps	LP Mode

(table continues...)

Table 19 (continued) SCB

Spec ID	Parameter	Symbol	Values			Unit	Note or test condition
			Min.	Typ.	Max.		
Fixed SPI DC Specifications							
SID163	Block current consumption at 1Mbits/sec	ISPI1	-	-	220	µA	
SID164	Block current consumption at 4 Mbits/sec	ISPI2	-	-	340	µA	
SID165	Block current consumption at 8 Mbits/sec	ISPI3	-	-	360	µA	
SID165A	Block current consumption at 25 Mbits/sec	ISP14	-	-	800	µA	
Fixed SPI AC Specifications for LP Mode (1.1V) unless noted otherwise							
SID166	SPI Operating frequency Master and Externally Clocked Slave	FSPI_EXT	-	-	25	MHz	For LP, OD mode
SID166U	SPI Operating frequency Master and Externally Clocked Slave	FSPI_EXT_UL	-	-	6.25	MHz	For ULP mode
SID166A	SPI Operating frequency Master and Externally Clocked Slave for fast SCB	FSPI_EXT_HS	-	50	60	MHz	For LP mode = 50 MHz, OD mode = 60 MHz.
SID166AU	SPI Operating frequency Master and Externally Clocked Slave for fast SCB	FSPI_EXT_HS_UL	-	-	15/30	MHz	ULP / MF Mode
SID166B	SPI Operating frequency Master in LP and OD mode	FSPI	-	-	FSCB/4	MHz	LP, OD mode, FSCB = 100 MHz
SID166BU	SPI Operating frequency Master in ULP mode	FSPI_UL	-	-	FSCB/4	MHz	ULP mode, FSCB = 25 MHz
SID166BHS	SPI Operating frequency Master in high speed mode in LP and OD	FSPI_HS	-	-	FSCB/4	MHz	LP /OD mode, FSCB = 200 / 240 MHz
SID166BHS_UL	SPI Operating frequency Master in high speed mode in ULP	FSPI_HS_UL	-	-	FSCB/4	MHz	ULP mode, FSCB = 50 MHz
SID166C	SPI Slave Internally Clocked	FSPI_IC	-	-	100	MHz	LP, OD mode
SID166CHS	SPI Slave Internally Clocked in High Speed Mode	FSPI_IC_HS	-	200	240	MHz	Typical in LP mode and max in OD mode with High Speed SPI
SID166CUL	SPI Slave Internally Clocked	FSPI_IC_UL	-	-	25	MHz	ULP mode
SID166CUL_HS	SPI Slave Internally Clocked in High Speed Mode	FSPI_IC_UL_HS	-	60	120	MHz	Typical value in ULP and Max value in MF
Fixed SPI Master mode AC Specifications for LP Mode (1.1 V) unless noted otherwise							
SID167	MOSI Valid after SClock driving edge	TDMO	-	-	12	ns	LP, OD mode

(table continues...)

Table 19 (continued) SCB

Spec ID	Parameter	Symbol	Values			Unit	Note or test condition
			Min.	Typ.	Max.		
SID167UL	MOSI Valid after SClock driving edge	TDMO_UL	-	-	40	ns	ULP mode
SID167HS	MOSI Valid after SClock driving edge	TDMO_HS	-	-	15	ns	LP Mode, for 50 MHz operation
SID167HS_UL	MOSI Valid after SClock driving edge	TDMO_HS_UL	-	-	75	ns	ULP Mode, for 50 MHz operation
SID168	MISO Valid before SClock capturing edge	TDSI	20	-	-	ns	LP, OD Full clock, late MISO sampling
SID168_ULP	MISO Valid before SClock capturing edge	TDSI_ULP	105	-	-	ns	ULP, Full clock, late MISO sampling
SID168HS	MISO Valid before SClock capturing edge	TDSI_HS	15	-	-	ns	LP,OD Mode, for 50 MHz operation
SID168HS_ULP	MISO Valid before SClock capturing edge	TDSI_HS_UL	22	-	-	ns	ULP Mode, for 50 MHz operation
SID169	MOSI data hold time	THMO	0	-	-	ns	Refer to Slave capturing edge in LP and OD mode
SID169_UL	MOSI data hold time	THMO_UL	0	-	-	ns	Refer to Slave capturing edge in ULP and MF mode
SID169HS	MOSI data hold time in HS mode	THMO_HS	0	-	-	ns	Refer to Slave capturing edge for HS SPI in LP and OD mode
SID169HS_UL	MOSI data hold time	THMO_HS_UL	0	-	-	ns	Refer to Slave capturing edge for HS SPI in ULP and MF mode
SID169A	SSEL Valid to first SCK Valid edge	TSSELMCK1	20	-	-	ns	Refer to Master clock edge for all modes and SPI and HS SPI
SID169B	SSEL Hold after last SCK Valid edge	TSSELMCK2	20	-	-	ns	Refer to Master clock edge for all modes and SPI and HS SPI

Fixed SPI Slave mode AC Specifications for LP Mode (1.1V) unless noted otherwise

SID170	MOSI Valid before Sclock Capturing edge	TDMI	5	-	-	ns	LP, OD mode
SID170_UL	MOSI Valid before Sclock Capturing edge	TDMI_UL	24	-	-	ns	ULP mode

(table continues...)

Table 19 (continued) SCB

Spec ID	Parameter	Symbol	Values			Unit	Note or test condition
			Min.	Typ.	Max.		
SID170_HS	MOSI Valid before Sclock Capturing edge	TDMI_HS	4	-	-	ns	LP , OD Mode, for 50 MHz operation
SID170_HS_UL	MOSI Valid before Sclock Capturing edge	TDMI_HS_UL	14	-	-	ns	ULP, MF Mode, for 50 MHz operation
SID170A	MOSI Hhold from SCLK	TSIH_EXT	2.5	-	-	ns	LP, OD mode
SID170A_UL	MOSI Hhold from SCLK	TSIH_EXT_UL	5	-	-	ns	ULP and MF mode
SID171A	MISO Valid after Sclock driving edge in Ext. Clk. mode	TDSO_EXT	-	-	20	ns	LP, OD mode
SID171A_UL	MISO Valid after Sclock driving edge in Ext. Clk. mode	TDSO_EXT_UL	-	-	35	ns	ULP mode
SID171A_HS	MISO Valid after Sclock driving edge in Ext. Clk. mode	TDSO_EXT_HS	-	-	16	ns	LP, OD mode, for 50 MHz operation
SID171A_HS_UL	MISO Valid after Sclock driving edge in Ext. Clk. mode	TDSO_EXT_HS_UL	-	-	25	ns	ULP , MF mode, for 50 MHz operation
SID171	MISO Valid after Sclock driving edge in Internally Clk. Mode	TDSO	-	-	TDSO_EXT + 3*Tscb	ns	Tscb is Serial Comm Block clock period.
SID171B	MISO Valid after Sclock driving edge in Internally Clk. Mode with Median filter enabled.	TDSO_M	-	-	TDSO_EXT + 4*Tscb	ns	Tscb is Serial Comm Block clock period.
SID172	MOSI and MISO data hold time	THSO	5	-	-	ns	
SID172A	SSEL Valid to first SCK Valid edge	TSSELSCK1	4*Tscb	-	-	ns	
SID172B	SSEL Hold after Last SCK Valid edge	TSSELSCK2	4*Tscb	-	-	ns	
SID172C	MISO valid after SSEL falling edge	TVSS_EXT	-	-	20	ns	For LP and OD mode
SID172C_ULP	MISO valid after SSEL falling edge	TVSS_EXT_ULP	-	-	35	ns	For ULP and MF mode
SID172C_HS	MISO valid after SSEL falling edge	TVSS_EXT_HS	-	-	16	ns	High Speed SPI, LP and OD mode
SID172C_HS_UL	MISO valid after SSEL falling edge	TVSS_EXT_HS_UL	-	25	27	ns	High Speed SPI, typical value for MF mode and max value at ULP mode.

7.5 Memory

Table 20 Memory

Spec ID	Parameter	Symbol	Values			Unit	Note or test condition
			Min.	Typ.	Max.		
Flash DC Specifications							
SID173	Erase and Program voltage	VPE	1.71	-	3.6	V	Erase and program not supported at ULP levels (0.9 V)
SID173A	Erase and Program current	IPE	-	-	6	mA	Guaranteed by design
Flash AC Specifications							
SID174	Row(Block) write time (erase & program)	TROWWRITE	-	-	16	ms	Row (Block) = 512 Bytes
SID175	Row erase time	TROWERASE	-	-	11	ms	
SID176	Row program time after erase	TROWPROGR AM	-	-	5	ms	
SID178	Bulk erase time (256K Bytes)	TBULKERASE	-	-	11	ms	
SID179	Sector erase time (128K bytes)	TSECTORERA SE	-	-	11	ms	256 Rows per sector
SID178S	Sub-Sector erase time	TSSERIAE	-	-	11	ms	8 Rows per sub-sector
SID179S	Sub-Sector write time; 1 erase plus 8 program times	TSSWRITE	-	-	51	ms	
SID180S	Sector write time; 1 erase plus 256 program times	TSSWRITE	-	-	1.3	seconds	
SID180	Total Device Program time	TDEVPROG	-	-	2.6	seconds	
SID181	Flash Endurance	FEND	100K	-	-	cycles	
SID182	Flash Retention. Ta <= 25°C, 100K P/E cycles	FRET1	10	-	-	years	
SID182A	Flash Retention. Ta <= 85°C, 10K P/E cycles	FRET2	10	-	-	years	
SID182B	Flash Retention. Ta <= 55°C, 20K P/E cycles	FRET3	20	-	-	years	
SID256	Number of Wait states at 150 MHz	TWS100	-	-	8		LP Mode (1.1 V)
SID256A	Number of Wait states at 180 MHz	TWS100	-	-	9		OD Mode (1.2 V)

7.6 System Resource

7.6.1 Power-on reset (POR)

Table 21 POR

Spec ID	Parameter	Symbol	Values			Unit	Note or test condition
			Min.	Typ.	Max.		

Boy II System Resources

Power-On-Reset with Brown-out DC Specifications

SID190	BOD trip voltage in Active and Sleep modes. VDDD.	VFALLPPOR	1.54	-	-	V	BOD Reset guaranteed for levels below 1.54 V
SID192	BOD trip voltage in Deep Sleep. VDDD	VFALLDPSLP	1.54	-	-	V	
SID192A	Maximum power supply ramp rate (any supply)	VDDRAMP	-	-	100	mV/ uSec	Active Mode

POR with Brown-out AC Specification

SID194A	Maximum power supply ramp rate (any supply) in Deep Sleep	VDDRAMP_DS	-	-	10	mV/ uSec	BOD operation guaranteed
---------	---	------------	---	---	----	-------------	--------------------------

7.6.2 Voltage monitors

Table 22 Voltage Monitors

Spec ID	Parameter	Symbol	Values			Unit	Note or test condition
			Min.	Typ.	Max.		

Voltage Monitors DC Specifications

SID196		VHVDI2	1.52	1.64	1.75	V	
SID197		VHVDI3	1.71	1.79	1.86	V	
SID198		VHVDI4	1.90	1.99	2.07	V	
SID199		VHVDI5	2.00	2.09	2.17	V	
SID200		VHVDI6	2.10	2.19	2.27	V	
SID201		VHVDI7	2.19	2.29	2.38	V	
SID202	VHVDI8	VHVDI8	2.29	2.39	2.48	V	
SID203		VHVDI9	2.39	2.49	2.58	V	
SID204		VHVDI10	2.48	2.59	2.69	V	
SID205		VHVDI11	2.58	2.69	2.79	V	
SID206		VHVDI12	2.68	2.79	2.89	V	
SID207		VHVDI13	2.77	2.89	3.00	V	
SID208		VHVDI14	2.87	2.99	3.10	V	
SID209		VHVDI15	2.97	3.09	3.20	V	
SID211	Block current	LVI_IDD	-	5	15	uA	

7.6.3 Single Wire Debug (SWD) and Trace Interface

Table 23 SWD and Trace Interface

Spec ID	Parameter	Symbol	Values			Unit	Note or test condition
			Min.	Typ.	Max.		
SID214	1.71 V ≤ VDDD ≤ 3.6 V	F_SWDCCLK2	-	-	25	MHz	OD Mode; VCCD = 1.2 V
SID214LP	1.71 V ≤ VDDD ≤ 3.6 V	F_SWDCCLK2	-	-	20	MHz	LP Mode; VCCD = 1.1 V
SID214L	1.71 V ≤ VDDD ≤ 3.6 V	F_SWDCCLK2L	-	-	12	MHz	ULP and MF Mode. VCCD = 0.9 V and 1.0 V
SID215	T = 1/f SWDCCLK	T_SWDI_SETUP	0.25*T	-	-	ns	
SID216	T = 1/f SWDCCLK	T_SWDI_HOLD	0.25*T	-	-	ns	
SID217	T = 1/f SWDCCLK	T_SWDO_VALID	-	-	0.5*T	ns	
SID217A	T = 1/f SWDCCLK	T_SWDO_HOLD	1	-	-	ns	
SID214T	With Trace Data setup/hold times of 2/1 ns respectively	F_TRCLK_LP1	-	-	90	MHz	OD Mode. VCCD = 1.2 V with load capacitance =15 pF
SID215T	With Trace Data setup/hold times of 2/1 ns respectively	F_TRCLK_LP2	-	-	75	MHz	LP Mode. VCCD = 1.1 V with load capacitance =15 pF
SID216T	With Trace Data setup/hold times of 3/2 ns respectively	F_TRCLK_LP3	-	-	50	MHz	MF Mode. VCCD = 1.0 V with load capacitance =15 pF
SID217T	With Trace Data setup/hold times of 3/2 ns respectively	F_TRCLK_ULP	-	-	25	MHz	ULP Mode. VCCD = 0.9 V with load capacitance =15 pF

7.6.4 Internal oscillator crystal oscillator and external clock specifications

Table 24 Internal Oscillator Crystal Oscillator and External Clock Specifications

Spec ID	Parameter	Symbol	Values			Unit	Note or test condition
			Min.	Typ.	Max.		
SID218	IMO Operating current at 8 MHz	IIMO1	-	9	15	µA	Guaranteed by Design

(table continues...)

7 Electrical specifications

Table 24 (continued) Internal Oscillator Crystal Oscillator and External Clock Specifications

Spec ID	Parameter	Symbol	Values			Unit	Note or test condition
			Min.	Typ.	Max.		
IMO AC Specifications							
SID223	Frequency variation centered on 8 MHz	FIMOTOL1	-	-	±2	%	
SID227	Cycle-to-Cycle and Period jitter	TJITR	-	250	-	ps	
IHO DC Specifications							
SID218A	IHO Operating current at 48 MHz	IHO1	-	80	100	µA	Guaranteed by Design
IHO AC Specifications							
SID223A	Frequency variation centered on 48 MHz	FIHOTOL1	-	-	±1	%	
SID227A	Cycle-to-Cycle and Period jitter	TJITR	-	60	-	ps	
ILO DC Specifications							
SID231	ILO Operating current at 32 KHz	ILO2	-	0.3	0.7	µA	Guaranteed by Design
ILO AC Specifications							
SID234	ILO Start-up time	TSTARTILO1	-	-	7	µs	Startup time to 95% of final frequency
SID236	ILO Duty cycle	TLIODUTY	45	50	55	%	
SID237	32 KHz trimmed frequency	FILOTRIM1	28.8	32	35.2	KHz	+/-10% variation
Frequency Locked Loop (FLL) Specifications							
SID451	Output frequency range. VCCD = 1.2V/1.1V	FLL_OUT_DIV 2_1	24	-	100	MHz	Output range of FLL divided-by-2 output
SID451A	Output frequency range. VCCD = 0.9V	FLL_OUT_DIV 2_2	24.00	-	50.00	MHz	Output range of FLL divided-by-2 output
SID452	Divided-by-2 output; High or Low	FLL_DUTY_DI V2	47.00	-	53.00	%	Guaranteed by Design
SID454	Time from stable input clock to 1% of final value on deep sleep wakeup	FLL_WAKEUP	-	-	7.50	µs	With IMO input, for < 10°C change in temperature while in Deep Sleep and Fout ≥ 50 Mhz
SID455	Period jitter (1 sigma) at 100 MHz	FLL_JITTER	50	-	35	pS	Min. Value is at 48 MHz. Guaranteed by Design
SID456	CCO + Logic current	FLL_CURREN T	-	-	2	µA/M Hz	

(table continues...)

Table 24 (continued) Internal Oscillator Crystal Oscillator and External Clock Specifications

Spec ID	Parameter	Symbol	Values			Unit	Note or test condition
			Min.	Typ.	Max.		
MHz ECO DC Specification							
SID316	Block operating current with load up to 18 pF.	I _{dd_MHz}	-	800	2200	μA	Max at 33 MHz. Typ at 16 MHz.
MHz ECO AC Specification							
SID317	Crystal frequency range	F_MHz	4	-	36	MHz	
External Clock Specification							
SID_EXT	External Clock Max input frequency	FEXT	-	-	80	MHz	in OD and LP mode, duty cycle between 45% and 55% and max rise/fall time of 20% period
SID_EXT1	External Clock Max input frequency in MF mode	FEXT_MF	-	-	50	MHz	in MF mode, duty cycle between 45% and 55% and max rise/fall time of 20% period
SID_EXT2	External Clock Max input frequency in ULP mode	FEXT_ULP	-	-	40	MHz	in ULP mode, duty cycle between 45% and 55% and max rise/fall time of 20% period
kHz WCO DC Specification							
SID318	Block operating current with 32 kHz crystal	I _{dd_kHz}	-	0.38	1	μA	
SID321E	Equivalent Series Resistance	ESR32K	-	80	-	kΩ	
SID322E	Drive Level	PD32K	-	-	1	μW	
kHz WCO AC Specification							
SID319	32 KHz trimmed frequency	F_kHz	-	32768	-	KHz	
SID320K	Startup time	T _{on_kHz}	-	-	1000	ms	
SID320E	Frequency tolerance	FTOL32K	-	50	250	ppm	May be calibrated to sub-10 ppm levels
DPLL Specifications							
SIDPLL.0	Time to achieve PLL Lock at 4 MHz reference	PLL_LOCK_4M	-	-	20	μS	
SIDPLL.1	Time to achieve PLL Lock at 8 MHz reference	PLL_LOCK_8M	-	-	20	μS	
SIDPLL.2	Output frequency from PLL Block	PLL_OUT	-	160	240	MHz	

(table continues...)

Table 24 (continued) Internal Oscillator Crystal Oscillator and External Clock Specifications

Spec ID	Parameter	Symbol	Values			Unit	Note or test condition
			Min.	Typ.	Max.		
SIDPLL.3	PLL Current	PLL_IDD	-	800	1200	uA	For PLL_OUT = 240 MHz
SIDPLL.4	Period jitter	PLL_PJTR_100	-200	-	200	pS	for PLL_OUT = 100 MHz
SIDPLL.4A	Period jitter	PLL_PJTR_200	-100	-	100	pS	for PLL_OUT = 200 MHz
SIDPLL.4B	Period jitter	PLL_PJTR_240	-80	-	80	pS	for PLL_OUT = 240 MHz
SIDPLL.7	Duty Cycle	PLL_DC	45	-	55	%	for PLL_OUT = Fdco/N, N > 1 and integer

7.7 Smart I/O

Table 25 SMARTIO

Spec ID	Parameter	Symbol	Values			Unit	Note or test condition
			Min.	Typ.	Max.		
SID420	Smart I/O Bypass delay	SMIO_BYP	-	-	2	nS	For LP mode
SID421	Smart I/O LUT prop delay	SMIO_LUT	-	6	-	nS	For LP Mode with VDDD = 3.3 V

7.8 JTAG boundary scan specifications

Table 26 JTAG boundary scan specifications

Spec ID	Parameter	Symbol	Values			Unit	Note or test condition
			Min.	Typ.	Max.		

JTAG: Parameters for 1.2 V (OD) and 1.1 V (LP) mode operations

SID460	TCK low Mmimum	TCKLOW	34	-	-	nS	
SID461	TCK high	TCKHIGH	10	-	-	nS	
SID461A	Clock Period , 30 pF Load	TCK_PERIOD	-	62	-	nS	
SID462	TDO clock-to-out (max) from falling TCK	TCK_TDO	-	-	22	nS	
SID463	TDO clock-to-out (max) from falling TCK	TSU_TCK	12	-	-	nS	
SID464	TDI, TMS Hold time after rising TCK.	TCK_THD	10	-	-	nS	
SID465	TCK to TDO Data Valid (high-Z to active).	TCK_TDOV	22	-	-	nS	
SID466	TCK to TDO Data Valid (active to high-Z).	TCK_TDOZ	22	-	-	nS	

(table continues...)

Table 26 (continued) JTAG boundary scan specifications

Spec ID	Parameter	Symbol	Values			Unit	Note or test condition
			Min.	Typ.	Max.		
SID467	JTAG TDO Hold Time	JTAG_TDO_HOLD	-	-	5	nS	
SID467A	JTAG Input Transition Time	JTAG_INPUT_TRANSITION_TIME	-	-	5	nS	

JTAG: Parameters for 1.0 V (MF) and 0.9 V (ULP) mode operations

SID483	TCK low Mmimum	TCKLOW	60	-	-	nS	
SID484	TCK high	TCKHIGH	20	-	-	nS	
SID485	Clock Period , 30 pF Load	TCK_PERIOD	-	80	-	nS	
SID486	TDO clock-to-out (max) from falling TCK	TCK_TDO	-	-	40	nS	
SID487	TDI, TMS Setup time before rising TCK.	TSU_TCK	20	-	-	nS	
SID488	TDI, TMS Hold time after rising TCK.	TCK_THD	20	-	-	nS	
SID489	TCK to TDO Data Valid (high-Z to active).	TCK_TDOV	50	-	-	nS	For MF mode , 40 shall be used.
SID490	TCK to TDO Data Valid (active to high-Z).	TCK_TDOZ	40	-	-	nS	
SID491	JTAG TDO Hold Time	JTAG_TDO_HOLD	-	-	5	nS	
SID492	JTAG Input Transition Time	JTAG_INPUT_TRANSITION_TIME	-	-	5	nS	

JTAG Boundary Scan Parameters for 1.2 V (OD) and 1.1 V (LP) mode operation:

SID468	TCK low	TCKLOW	52	-	-	nS	
SID469	TCK high	TCKHIGH	10	-	-	nS	
SID469A	CLK_JTAG_PERIOD, 30 pF Load	TCKPERIOD	-	62	-	nS	
SID470	TCK falling edge to output valid	TCK_TDO	-	-	40	nS	
SID471	Input valid to TCK rising edge	TSU_TCK	12	-	-	nS	
SID472	Input hold time to TCK rising edge	TCK_THD	10	-	-	nS	
SID473	TCK falling edge to output valid (high-Z to active).	TCK_TDOV	40	-	-	nS	
SID474	TCK falling edge to output valid (active to high-Z).	TCK_TDOZ	40	-	-	nS	
SID474A	JTAG_BSCAN_TDO_HOLD	TCK_TDOH	-	-	5	nS	

JTAG Boundary Scan Parameters for 1.0 (MF) and 0.9 V (ULP) mode operation:

SID475	TCK low	TCKLOW	102	-	-	nS	
--------	---------	--------	-----	---	---	----	--

(table continues...)

Table 26 (continued) JTAG boundary scan specifications

Spec ID	Parameter	Symbol	Values			Unit	Note or test condition
			Min.	Typ.	Max.		
SID476	TCK high	TCKHIGH	20	-	-	nS	
SID476A	CLK_JTAG_PERIOD, 30pF Load	TCKPERIOD	-	122	-	nS	
SID478	TCK falling edge to output valid	TCK_TDO	-	-	80	nS	
SID479	Input valid to TCK rising edge	TSU_TCK	22	-	-	nS	
SID480	Input hold time to TCK rising edge	TCK_THD	20	-	-	nS	
SID481	TCK falling edge to output valid (high-Z to active).	TCK_TDOV	80	-	-	nS	
SID482	TCK falling edge to output valid (active to high-Z).	TCK_TDOZ	80	-	-	nS	

8 Ordering information

Table 27 lists the PSC3P5x, PSC3M5x device part numbers and features. All devices include Arm® Cortex®-M33 with 180 MHz CPU speed, 64 KB SRAM, 2 ch CAN FD, 4 ch 32-bit timer with high-resolution PWM support, 16 ch 16-bit timer, 5x comparators, Smart I/O, and CryptoLite.

Table 27 Ordering information

Product	Flash	ADC	CORDIC accelerator	MOTIF	SCB(UART, SPI, I2C)	Pin
PSC3P5EDLGQ1	128 KB	12 Msps, 12 ch	No	-	4 ¹⁾	VQFN-48
PSC3P5FDS2LGQ1	256 KB ²⁾	12 Msps, 12 ch	No	-	4 ¹⁾	VQFN-48
PSC3P5EDABQ1	128 KB	12 Msps, 12 ch	No	-	4 ¹⁾	E-LQFP-48
PSC3P5FDS2ABQ1	256 KB ²⁾	12 Msps, 12 ch	No	-	4 ¹⁾	E-LQFP-48
PSC3P5EDLHQ1	128 KB	12 Msps, 18 ch	No	-	6	VQFN-64
PSC3P5FDS2LHQ1	256 KB ²⁾	12 Msps, 18 ch	No	-	6	VQFN-64
PSC3P5EDACQ1	128 KB	12 Msps, 18 ch	No	-	6	E-LQFP-64
PSC3P5FDS2ACQ1	256 KB ²⁾	12 Msps, 18 ch	No	-	6	E-LQFP-64
PSC3M5EDLGQ1	128 KB	12 Msps, 12 ch	Yes	Hall/Encoder	4 ¹⁾	VQFN-48
PSC3M5FDS2LGQ1	256 KB ²⁾	12 Msps, 12 ch	Yes	Hall/Encoder	4 ¹⁾	VQFN-48
PSC3M5EDABQ1	128 KB	12 Msps, 12 ch	Yes	Hall/Encoder	4 ¹⁾	E-LQFP-48
PSC3M5FDS2ABQ1	256 KB ²⁾	12 Msps, 12 ch	Yes	Hall/Encoder	4 ¹⁾	E-LQFP-48
PSC3M5EDLHQ1	128 KB	12 Msps, 18 ch	Yes	Hall/Encoder	6	VQFN-64
PSC3M5FDS2LHQ1	256 KB ²⁾	12 Msps, 18 ch	Yes	Hall/Encoder	6	VQFN-64
PSC3M5EDACQ1	128 KB	12 Msps, 18 ch	Yes	Hall/Encoder	6	E-LQFP-64

(table continues...)

Table 27 (continued) Ordering information

Product	Flash	ADC	CORDIC accelerator	MOTIF	SCB(UART, SPI, I2C)	Pin
PSC3M5FDS2ACQ1	256 KB ²⁾	12 Msps, 18 ch	Yes	Hall/Encoder	6	E-LQFP-64
PSC3M5EDAFQ1	128 KB	12 Msps, 18 ch	Yes	Hall/Encoder	6	E-LQFP-80
PSC3M5FDS2AFQ1	256 KB ²⁾	12 Msps, 18 ch	Yes	Hall/Encoder	6	E-LQFP-80

- 1) SCB4 and SCB5 not available in 48-pin devices
- 2) PSA L2 certification is applicable only for devices with Flash of 256KB

8.1 Part number nomenclature

PSOC™ Control C3 MPN decoder:

PS C3 A B CC DD E FF G H II J K

Field	Description	Values	Meaning
PS	Brand	PS	Brand
C3	Family	C3	Family
A	Series	P	Power control
		M	Motor control
B	Sub-series	Entry Line	1-3
		Main Line	4-6
		Performance Line	7-9
CC	Memory (Flash/SRAM)	A	8 KB
		B	16 KB
		C	32 KB
		D	64 KB
		E	128 KB
		F	256 KB
		G	512KB
		H	768 KB
		J	1 MB
		K	2 MB
		L	3 MB

8 Ordering information

Field	Description	Values	Meaning
		M	4 MB
		N	6 MB
		O	7 MB
		P	8 MB
DD	Security	S2	PSA L2(PSA certification level)
E	Special attributes	D	Dual Core
		P	Programmable Power Control Sub-System
FF	Package	AB	EQFP-48 (0.5 mm)
		AC	EQFP-64 (0.5 mm)
		AF	EQFP-80 (0.5 mm)
		AH	QFP-100 (0.5 mm)
		AI	QFP-128 (0.5 mm)
		AE	QFP-144 (0.5 mm)
		LB	VQFN-24 (0.5 mm)
		LC	VQFN-32 (0.5 mm)
		LE	VQFN-40 (0.4 mm)
		LF	VQFN-48 (0.35 mm)
		LG	VQFN-48 (0.4 mm)
		LH	VQFN-64 (0.4 mm)
G	Temperature	C	Consumer (0°C to +70°C)
		I	Industrial (-40°C to +85°C)
		Q	Extended range (-40°C to +105°C)
H	Maximum Core Frequency	1	100 - 199 MHz
		2	200 - 299 MHz
II	Sample (Optional)	ES	Engineering Sample
J	Revision	-	Base
		A	Die revision
K	Packing (Optional)	T	Tape & Reel
		-	Tray

9 Package information

The PSC3P5xD and PSC3M5xD devices are offered in VQFN-48, E-LQFP-48, VQFN-64, E-LQFP-64, and E-LQFP-80 packages.

For pinout details, see [Pins](#).

Table 28 Package dimensions

Spec ID#	Package	Description	Package Dwg #
PKG_1	E-LQFP-80	E-LQFP-80, 12.0 mm x 12.0 mm x 1.6 mm height with 0.5 mm pitch, 4.6 x 4.6 mm EPAD	002-38596 Rev. *A
PKG_2	E-LQFP-64	E-LQFP-64, 10.0 mm x 10.0 mm x 1.6 mm height with 0.5 mm pitch, 4.0 x 4.0 mm EPAD	002-38595 Rev. *A
PKG_3	VQFN-64	VQFN-64, 8.0 mm x 8.0 mm x 0.9 mm height with 0.4 mm pitch, 4.2 x 4.2 mm EPAD (Sawn type)	002-40328 Rev **
PKG_4	E-LQFP-48	E-LQFP-48, 7.0 mm x 7.0 mm x 1.6 mm height with 0.5 mm pitch, 3.3 x 3.3 mm EPAD	002-40327 Rev **
PKG_5	VQFN-48	VQFN-48, 6.0 mm x 6.0 mm x 0.9 mm height with 0.4 mm pitch, 4.5 x 4.5 mm EPAD (Sawn type)	002-38593 Rev. **

Table 29 Package characteristics

Parameter	Description	Conditions	Min	Typ	Max	Units
T _A	Operating ambient temperature	-	-40	25	105	°C
T _J	Operating junction temperature, all packages	-	-40	-	125	°C
T _{JA}	Package θ_{JA} (E-LQFP-80)	-	-	27	-	°C/watt
T _{JC}	Package θ_{JC} (E-LQFP-80)	-	-	6	-	°C/watt
T _{JA}	Package θ_{JA} (E-LQFP-64)	-	-	31	-	°C/watt
T _{JC}	Package θ_{JC} (E-LQFP-64)	-	-	6	-	°C/watt

(table continues...)

Table 29 (continued) Package characteristics

Parameter	Description	Conditions	Min	Typ	Max	Units
T _{JA}	Package θ_{JA} (VQFN-64)	-	-	30	-	°C/watt
T _{JC}	Package θ_{JC} (VQFN-64)	-	-	4	-	°C/watt
T _{JA}	Package θ_{JA} (E- LQFP-48)	-	-	31	-	°C/watt
T _{JC}	Package θ_{JC} (E- LQFP-48)	-	-	5	-	°C/watt
T _{JA}	Package θ_{JA} (VQFN-48)	-	-	31	-	°C/watt
T _{JC}	Package θ_{JC} (VQFN-48)	-	-	3	-	°C/watt

Table 30 Solder reflow peak temperature

Package	Maximum peak temperature	Maximum time at peak temperature
All packages	260°C	30 seconds

Table 31 Package moisture sensitivity level (MSL), IPC/JEDEC J-STD-2

Package	MSL
All packages	MSL3

9 Package information

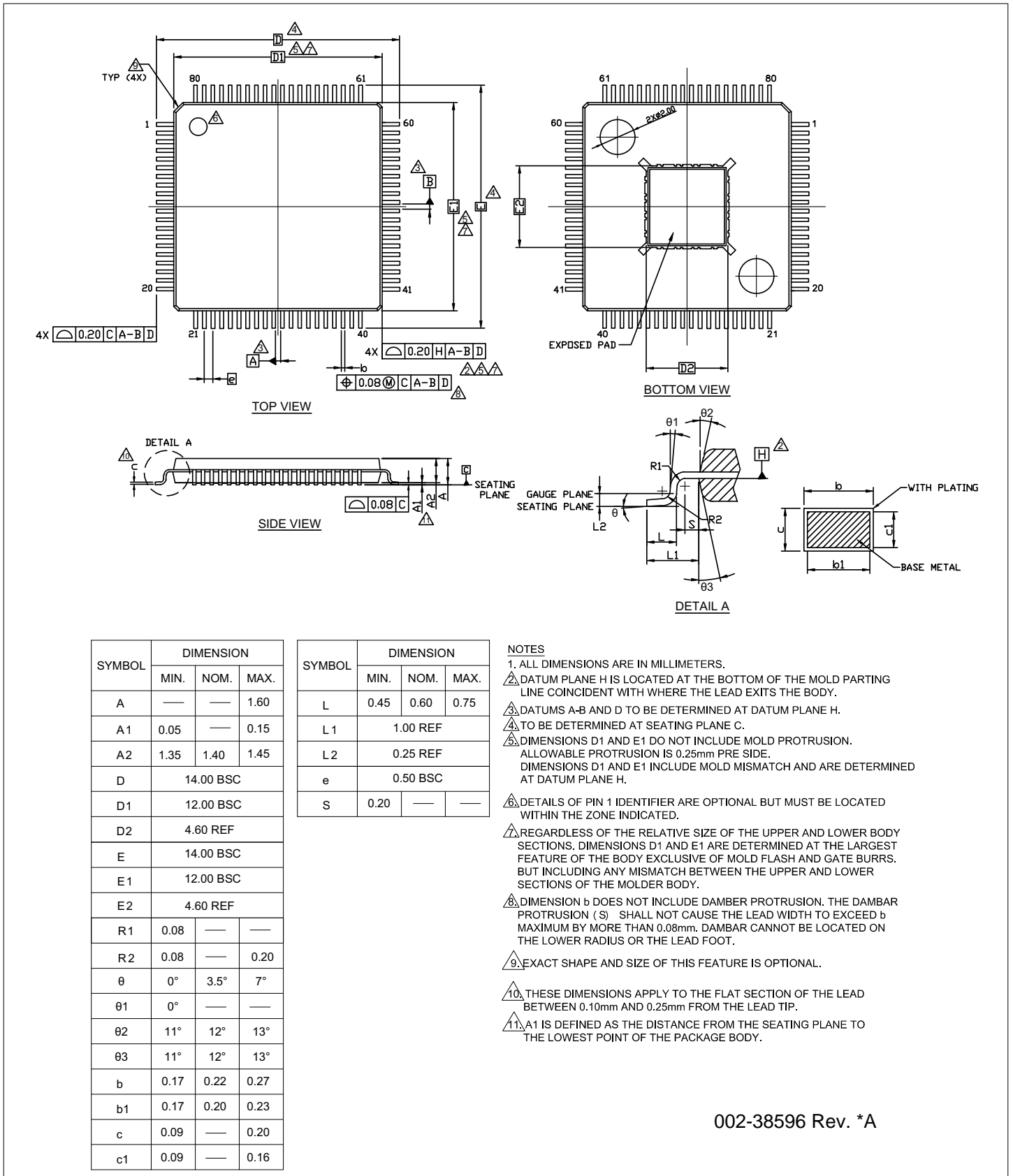
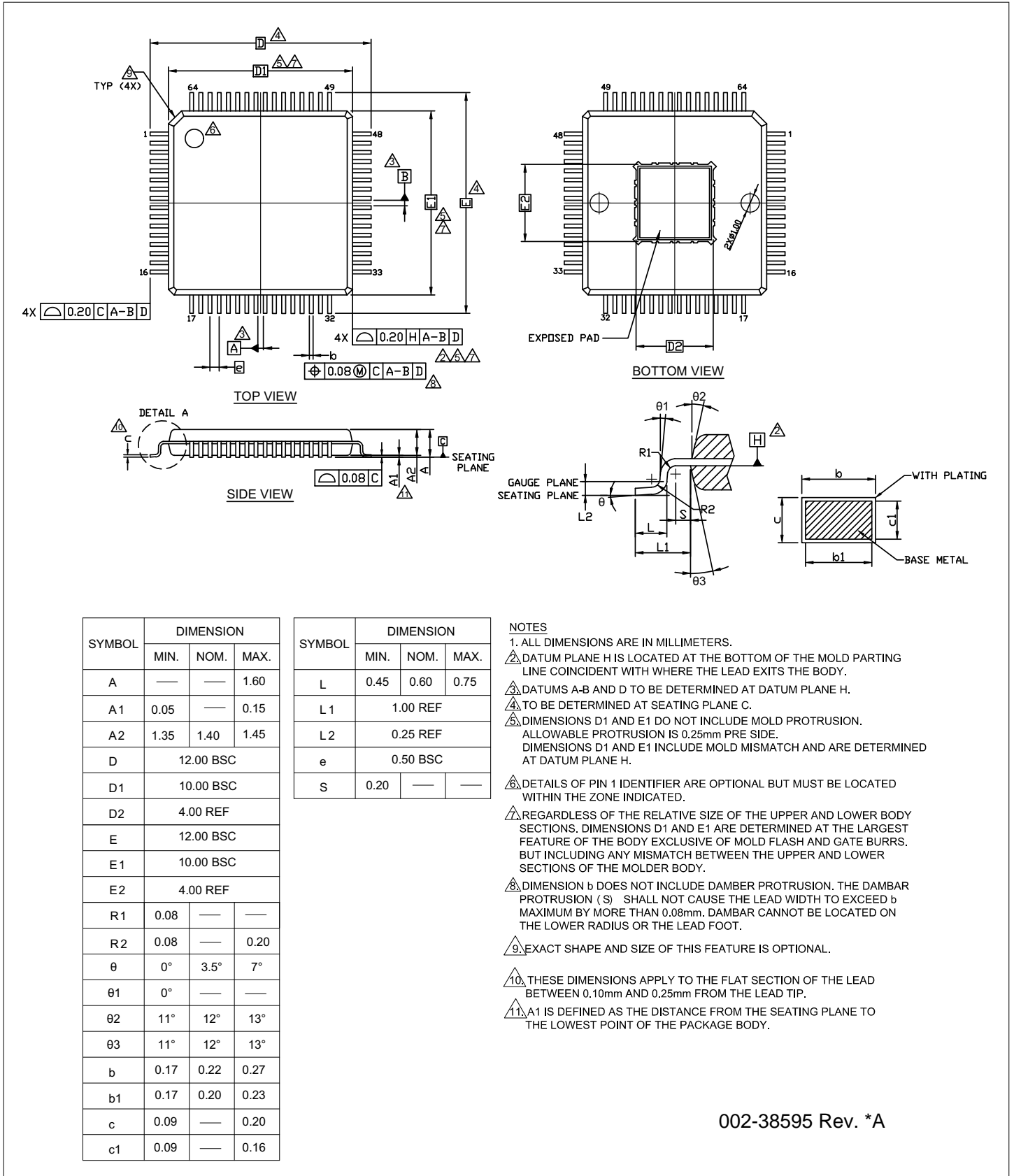

Figure 13 E-LQFP-80, 12x12x1.6 mm

002-38596 Rev. *A

9 Package information



002-38595 Rev. *A

Figure 14 E-LQFP-64, 10x10x1.6 mm

9 Package information

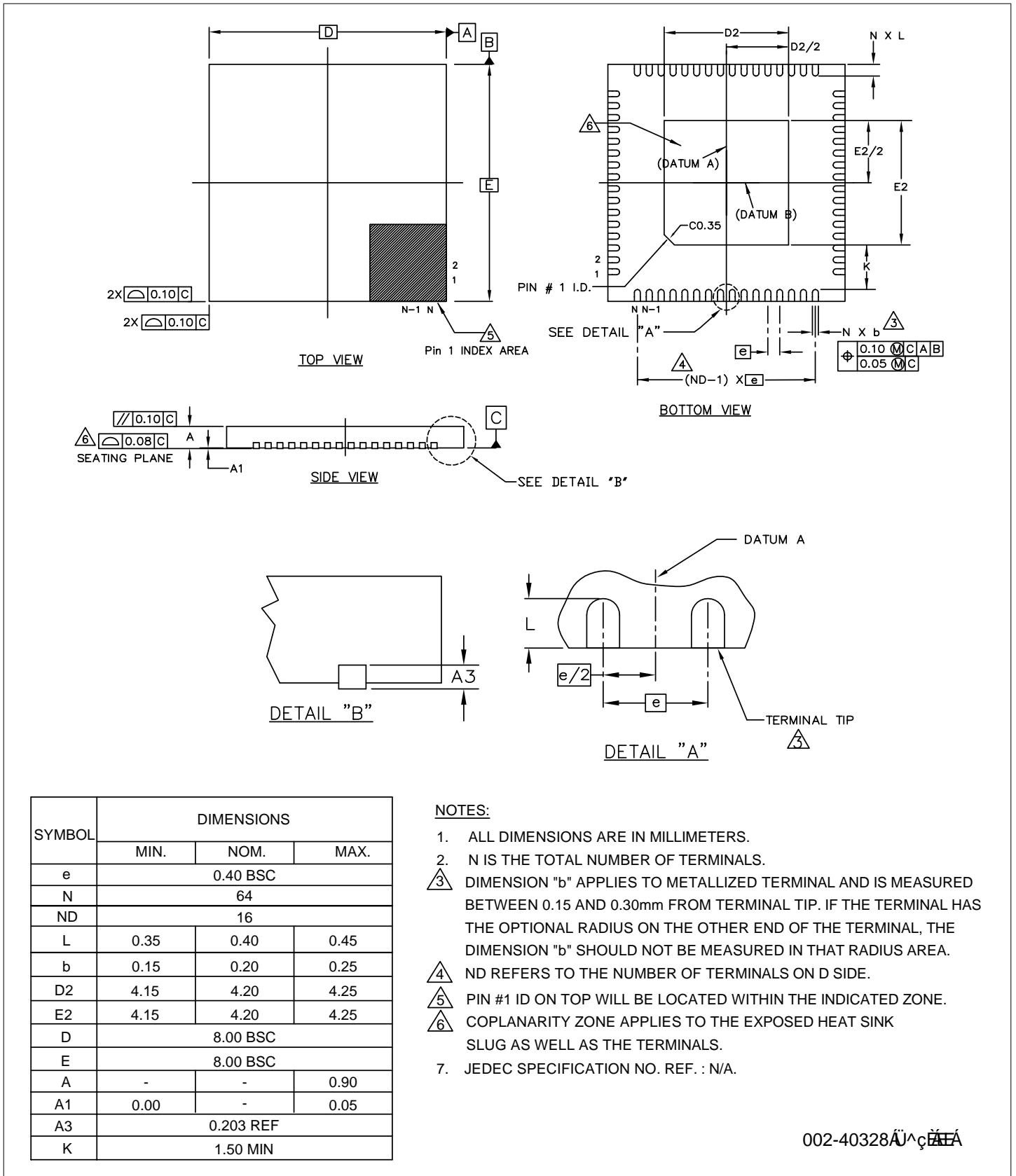

Figure 15 VQFN-64, 8x8x0.9 mm

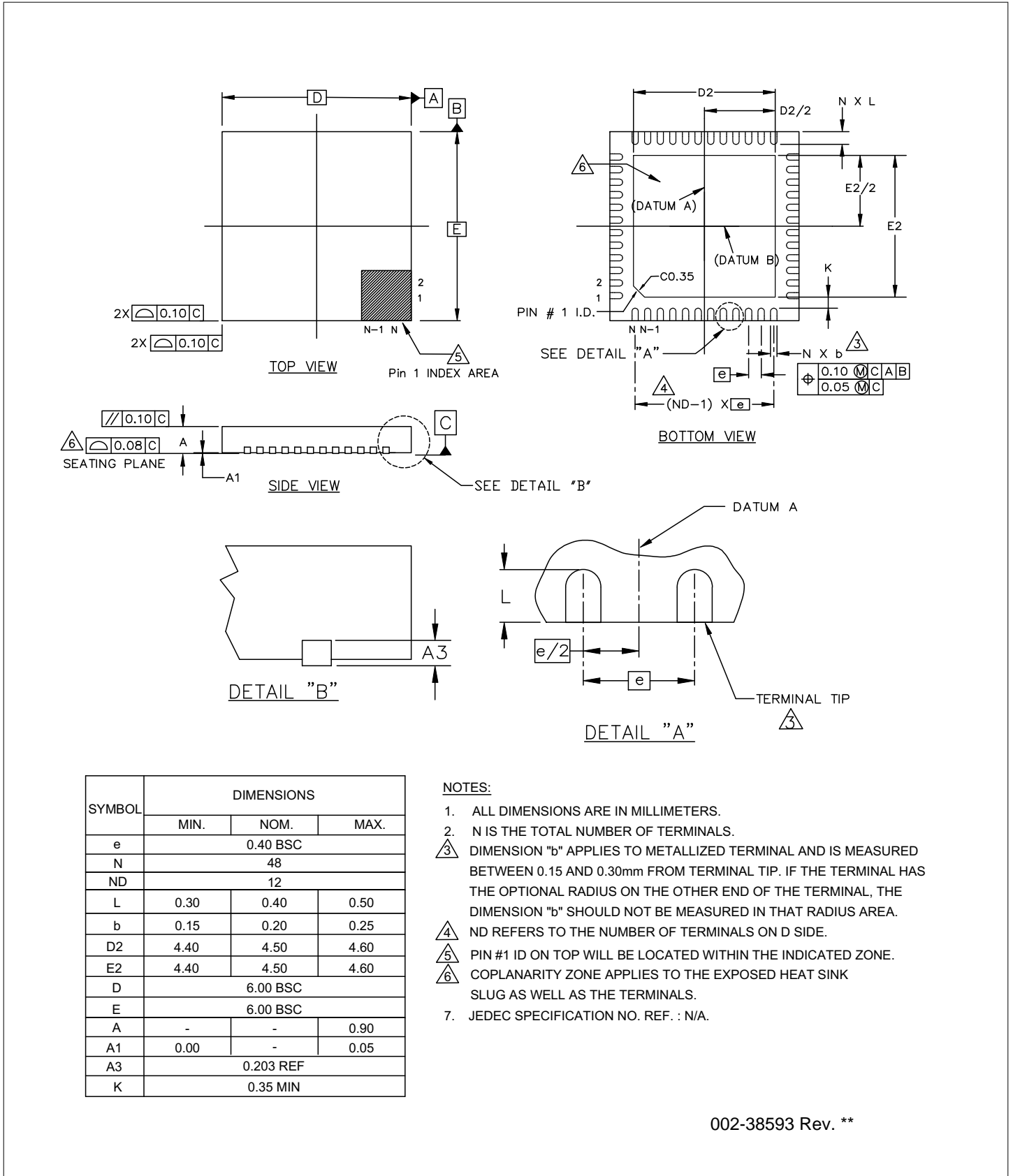

Figure 17 VQFN-48, 6x6x0.9 mm

10 Errata

This section describes the errata for the PSOC™ Control C3 MCU product line. Details include errata trigger conditions, scope of impact, available workarounds, and silicon revision applicability. For more details, contact [Infineon support](#).

Part numbers affected

Table 32 Part numbers affected

Part number	Device characteristics
All	PSOC™ Control C3 MCU product line

PSOC™ Control C3 qualification status

Production silicon

PSOC™ Control C3 errata summary

The following table defines the errata applicability of available product line devices.

Note: Click on any item entry to view its description.

Items	PSOC™ Control C3	Silicon revision	Fix status
[1]. FLL may not start properly after waking up from Deep Sleep in ULP and MF power profiles	All	1	Fix planned
[2]. Device is permanently non-responsive if Flash row 0 contains uncorrectable ECC errors	All	1	Fix planned
[3]. Deep Sleep wake-up operation is not reliable at VDDD < 2.3 V	All	1	Fix not planned
[4]. MCU cannot wake up from Deep Sleep-RAM or Deep Sleep-OFF mode using low-power comparator (LPCOMP) interrupt	All	1	Fix not planned
[5]. SCB: In I2C slave mode, the TXFIFO underflow interrupt is false triggered under certain conditions	All	1	Fix not planned
[6]. SCB: SPI master data output is incorrect for TI mode, MSB first, TX_WIDTH=4	All	1	Fix not planned
[7]. MCWDT_LOWER_LIMIT.WDT_LOWER_LIMIT0 is only supported for the first two 16-bit counters	All	1	Fix not planned
[8]. Counter direction change in timer mode after stop then start	All	1	Fix not planned
[9]. TCPWM KILL_STATUS bit is asserted falsely when the counter is not running	All	1	Fix not planned
[10]. PWM TC synchronous DT kill (PWM_TC_SYNC_KILL_DT=1) is not available in HRPWM mode	All	1	Fix not planned
[11]. CC0 match not generated at reload for 100% duty cycle with HRPWM enabled	All	1	Fix not planned

1. FLL may not start properly after waking up from Deep Sleep in ULP and MF power profiles

Problem definition	FLL may not start properly after waking up from Deep Sleep in ULP (VCCD = 0.9 V) and MF (VCCD = 1.0 V) power profiles.
Parameters affected	FLL output frequency.
Trigger condition	Deep Sleep wake up in ULP and MF power profiles with FLL enabled.
Scope of impact	FLL operation in ULP and MF modes after wake up from Deep Sleep.
Workaround	Set the SRSS.PWR_TRIM_WAKE_CTL register to 1 after selecting ULP or MF power profiles.
Fix status	Fix planned.

2. Device is permanently non-responsive if Flash row 0 contains uncorrectable ECC errors

Problem definition	Device is permanently non-responsive if Flash row 0 contains uncorrectable ECC errors.
Parameters affected	Device cannot be used.
Trigger conditions	<ol style="list-style-type: none"> 1. The Flash can be written using several different addresses. For example, address 0x2200 0000 and 0x3200 0000 map to the same physical row (row 0). If the device is programmed with hex files that contain data at 0x2200 0000 and 0x3200 0000, this may cause an ECC error that is not recoverable 2. Executing multiple Flash write operations without erase may cause Flash row 0 corruption 3. Device reset/power loss during Flash row 0 programming
Scope of impact	Device becomes permanently non-responsive
Workaround	<ol style="list-style-type: none"> 1. When working with Secure and Non-Secure applications, ensure that the combined hex file does not have data overlap at the Flash row 0 location 2. Always perform an erase operation before programming the Flash row 0 3. Ensure that the device power supply is stable and XRES is not asserted by user during Flash row 0 programming
Fix status	Fix planned.

3. Deep Sleep wake-up operation is not reliable at VDDD < 2.3 V

Problem definition	For VDDD < 2.3 V, Deep Sleep wake-up operation may lead to a system reset.
Parameters affected	MCU wake up from Deep Sleep or Deep Sleep-RAM modes.
Trigger condition	When device VDDD < 2.3 V, device is in Deep Sleep and a wake-up interrupt is triggered.
Scope of impact	Device is reset.
Workaround	Use VDDD ≥ 2.3 V when using Deep Sleep and Deep Sleep-RAM modes.

3. Deep Sleep wake-up operation is not reliable at VDDD < 2.3 V

Fix status	Fix not planned.
------------	------------------

4. MCU cannot wake up from Deep Sleep-RAM or Deep Sleep-OFF mode using low-power comparator (LPComp) interrupt

Problem definition	If LPComp interrupt is configured as wake up source for Deep Sleep-RAM or Deep Sleep-OFF mode, MCU cannot wake up when LPComp interrupt is asserted.
Parameters affected	MCU wake up from Deep Sleep-RAM or Deep Sleep-OFF modes.
Trigger condition	LPComp interrupt event for wake up from Deep Sleep-RAM or Deep Sleep-OFF modes.
Scope of impact	LPComp peripheral cannot be used as a wakeup source for Deep Sleep-RAM or Deep Sleep-OFF modes.
Workaround	Use Deep Sleep mode instead of Deep Sleep-RAM or Deep Sleep-OFF.
Fix status	Fix not planned.

5. SCB: In I2C slave mode, the TXFIFO underflow interrupt is false triggered under certain conditions

Problem definition	SCB: In I2C slave mode, the TXFIFO underflow interrupt is falsely triggered if an external master sends an ACK for the final byte read operation before the STOP or RESTART condition.
Parameters affected	TXFIFO underflow interrupt during I2C slave transmit operation.
Trigger condition	Triggered when an external I2C master sends an ACK for the final byte read transaction before STOP or RESTART.
Scope of impact	SCB in I2C slave mode during normal read operation.
Workaround	External I2C master needs to send a NACK for the last read operation before STOP or RESTART.
Fix status	Fix not planned.

6. SCB: SPI master data output is incorrect for TI mode, MSB first, TX_WDTH=4

Problem definition	If SCB is configured as SPI master TI mode, transmit FIFO is configured with 8 bits per FIFO data element (MEM_WIDTH=0), and transmit data frame is configured for 5 bits (TX_CTRL width=4), TX_CTRL.MSB_FIRST=1, the data output is incorrect.
Parameters affected	SPI data output is incorrect.
Trigger condition	SCB is configured as SPI master TI mode with an 8-bit transmit FIFO data element and TX_WDTH=4.
Scope of impact	Impacted in one specific configuration detailed above.
Workaround	None.
Fix status	Fix not planned.

7. MCWDT_LOWER_LIMIT.WDT_LOWER_LIMIT0 is only supported for the first two 16-bit counters

Problem definition	MCWDT_LOWER_LIMIT.WDT_LOWER_LIMIT0 is only supported for the first two 16-bit counters. It is disabled when the third 32-bit counter is cascaded (MCWDT_CONFIG.WDT_CASCADE1_2 == 1).
Parameters affected	Cascading of MCWDT counters beyond the first two 16-bit counters.
Trigger condition	When MCWDT_CONFIG.WDT_CASCADE1_2 == 1.
Scope of impact	MCWDT_LOWER_LIMIT.WDT_LOWER_LIMIT0 is only supported for the first two 16-bit counters.
Workaround	None.
Fix status	Fix not planned.

8. Counter direction change in timer mode after stop then start

Problem definition	In timer mode, value of TCPWM0_GRPx_CNTx_CTRL.UP_DOWN_MODE may change when the counter is stopped.
Parameters affected	Counter direction in timer mode.
Trigger condition	After counter is stopped and then started again in timer mode, direction may change.
Scope of impact	TCPWM in timer mode.
Workaround	When the counter is stopped, update the TCPWM0_GRPx_CNTx_CTRL.UP_DOWN_MODE value as per intended direction before restarting the counter.
Fix status	Fix not planned.

9. TCPWM KILL_STATUS bit is asserted falsely when the counter is not running

Problem definition	The KILL_STATUS bit is asserted falsely when the counter is not running.
Parameters affected	Only the KILL_STATUS flag bit visibility in software. PWM outputs are not impacted.
Trigger condition	Triggered when kill is enabled and the counter is not running due to: <ol style="list-style-type: none"> 1. Run mode set to one shot (TCPWM0_GRPx_CNTx_CTRL.ONE_SHOT = 1) 2. Counter is enabled (TCPWM0_GRPx_CNTx_CTRL.ENABLED = 1) but has not yet started running after being enabled
Scope of impact	Only when the counter is not running.
Workaround	Ignore the KILL_STATUS in the software when the counter is not running (TCPWM0_GRPx_CNTx_STATUS.RUNNING = 0).
Fix status	Fix not planned.

10. PWM TC synchronous DT kill (PWM_TC_SYNC_KILL_DT=1) is not available in HRPWM mode

Problem definition	PWM TC synchronous DT kill (PWM_TC_SYNC_KILL_DT=1) is not available in HRPWM mode.
--------------------	--

10. PWM TC synchronous DT kill (PWM_TC_SYNC_KILL_DT=1) is not available in HRPWM mode

Parameters affected	TC synchronous DT kill feature availability in HRPWM mode.
Trigger condition	When dead time is defined to be non-zero, PWM_TC_SYNC_KILL_DT=1 and HRPWM = 1.
Scope of impact	If dead-time is defined to be non-zero, the HRPWM line_out does not wait for dead-time after TC event when killed in PWM_TC_SYNC_KILL_DT mode.
Workaround	None.
Fix status	Fix not planned.

11. CC0 match not generated at reload for 100% duty cycle with HRPWM enabled

Problem definition	CC0 match not generated at reload for count down mode when HRPWM duty cycle is set to 100%.
Parameters affected	HRPWM duty cycle
Trigger condition	HRPWM in count down mode (TCPWM0_GRP0_CNTx_CTRL.UP_DOWN_MODE=1) and duty set to 100% (CC0 = period).
Scope of impact	HRPWM output in TCPWM0_GRP0_CNTx_CTRL.UP_DOWN_MODE=1 does not generate 100% duty cycle after reload when CC0 = period.
Workaround	Program CC0 to period-2 and CC0_BUFF to period and enable compare swap.
Fix status	Fix not planned.

11 Acronyms

Table 33 Acronyms used in this document

Acronym	Description
ADC	analog-to-digital converter
AES	advanced encryption standard
AMUX	analog multiplexer
BLDC	brushless direct current
BOD	brown-out detect
CAN	controller area network
CORDIC	coordinate rotation digital computer
CSV	clock supervision
DAC	digital to analog converter
DFU	device firmware upgrade
DSI	digital signal interconnect
DSP	digital signal processor
DMA	direct memory access
ECC	error correcting code
ECO	external crystal oscillators
ETB	embedded trace buffer
ETM	embedded trace macrocell
FET	field effect transistor
FIFO	first in, first out
FOC	field-oriented control
FPU	floating point unit
GPIO	general-purpose input/output
HPPASS	high-performance programmable analog subsystem
HRPWM	high-resolution pulse width modulator
HSIOM	high-speed I/O matrix
I-cache	instruction-cache
I2C	inter-integrated circuit
IHO	internal high-speed oscillator
ILO	low-speed oscillator
IMO	internal main oscillator
IPC	inter-processor communication
IRQ	interrupt request

(table continues...)

Table 33 (continued) Acronyms used in this document

Acronym	Description
ISR	interrupt service routine
LPComp	low-power comparator
LUT	lookup table
LVD	low-voltage detection
LVTTTL	low-voltage transistor-transistor logic
MCWDT	multi-counter watchdog timer
MPU	memory protection unit
NVIC	nested vectored interrupt controller
PAL	programmable array logic
PLD	programmable logic device
PLL	phase-locked loops
POR	power-on reset
ROM	read-only memory
RSA	rivest-shamir-adleman, a public-key cryptography algorithm
RTC	real-time clock
RWW	read-while-write
S/H	sample/hold
SAR	successive approximation register
SAU	secure attribution unit
SCB	serial communication blocks
SHA	secure hash algorithm
SPI	serial peripheral interface
SRAM	static random access memory
SRSS	system resources subsystem
TCPWM	timer/counter pulse-width modulator
TRNG	true random number generator
UART	universal asynchronous transmitter receiver
WCO	watch crystal oscillator
WIC	wakeup interrupt controller
XRES	external reset input pin

12 Document conventions

12.1 Units of measure

Table 34 Units of measure

Symbol	Unit of measure
°C	degree Celsius
KB	1024 bytes
kHz	kilohertz
Mbps	megabits per second
Msp/s	million samples per second
MHz	megahertz
ns	nanosecond
%	percent
V	volt

Revision history

Document version	Date of release	Description of changes
**	2022-09-26	Initial release
*A	2023-08-30	Updated the document title Added the Pins section Added the Low-power comparator (LPComp) section Updated the Block functional description section Updated TCPWM for HRPWM support Added the Ordering information section Added the Electrical specifications section
*B	2024-01-25	Updated the document title Added short product description Updated the Features section Updated the Potential applications section Updated the Description section Added chip symbol and marketing block diagram Added the Introduction section Updated Figure 1 Added the Chip-level functional description section Updated the Block functional description (previously "Functional description") Updated the Pins section Updated the Electrical specifications section Added the Package information section Added the Errata section
*C	2024-03-11	Added additional package images on first page Updated the Electrical specifications section Updated the Ordering information section Updated the Package information section
*D	2024-05-29	Updated package images on first page Updated Figure 1 Updated the Detailed features section Added the Device firmware update (DFU) section Updated the Pins section Updated the Electrical specifications section Updated the Package information section Updated the Errata section

Revision history

Document version	Date of release	Description of changes
*E	2024-12-20	Updated image and features on first page Updated Figure 1 Updated the Detailed features section Updated the Chip-level functional description section Updated the Clock system section Updated the 12-bit SAR analog-to-digital converter (ADC) section Updated the Serial communication block (SCB) section Updated the Trigger multiplexer (Trigger MUX) section Updated the Device firmware update (DFU) section Added the Serial wire JTAG debug port/Embedded trace macrocell section Updated the Pins section Updated the GPIO alternate functions tables section Updated the Electrical specifications section Updated the Ordering information section Updated the Package information section Updated the Errata section Publish to web

Trademarks

All referenced product or service names and trademarks are the property of their respective owners.

Edition 2024-12-20

Published by

Infineon Technologies AG

81726 Munich, Germany

© 2024 Infineon Technologies AG

All Rights Reserved.

Do you have a question about any aspect of this document?

Email: erratum@infineon.com

Document reference

IFX-hsj1659437234980

Important notice

The information given in this document shall in no event be regarded as a guarantee of conditions or characteristics ("Beschaffheitsgarantie").

With respect to any examples, hints or any typical values stated herein and/or any information regarding the application of the product, Infineon Technologies hereby disclaims any and all warranties and liabilities of any kind, including without limitation warranties of non-infringement of intellectual property rights of any third party.

In addition, any information given in this document is subject to customer's compliance with its obligations stated in this document and any applicable legal requirements, norms and standards concerning customer's products and any use of the product of Infineon Technologies in customer's applications.

The data contained in this document is exclusively intended for technically trained staff. It is the responsibility of customer's technical departments to evaluate the suitability of the product for the intended application and the completeness of the product information given in this document with respect to such application.

Warnings

Due to technical requirements products may contain dangerous substances. For information on the types in question please contact your nearest Infineon Technologies office.

Except as otherwise explicitly approved by Infineon Technologies in a written document signed by authorized representatives of Infineon Technologies, Infineon Technologies' products may not be used in any applications where a failure of the product or any consequences of the use thereof can reasonably be expected to result in personal injury.