

快速入门指南

KIT_DRIVER_2EDN7524F

2018 年 8 月



KIT_DRIVER_2EDN7524F



包含在此套件中

评估套件
KIT_DRIVER_2EDN7524F



TO-220 MOSFET
散热器

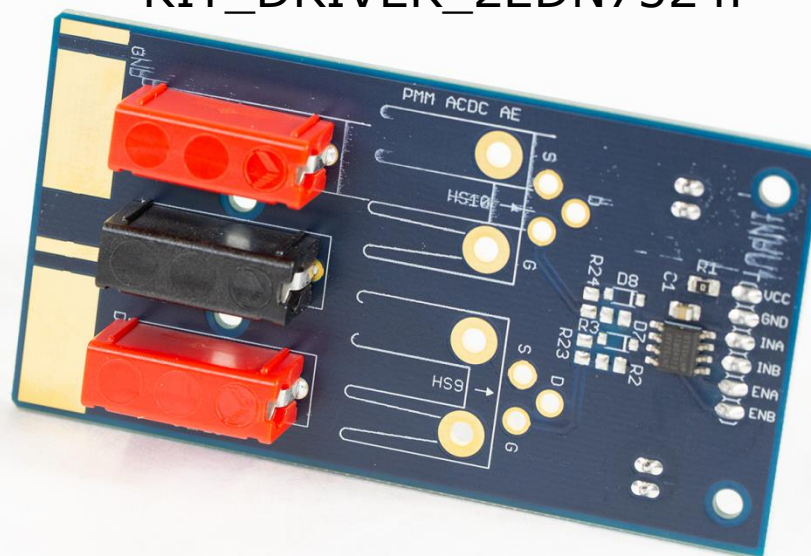

电路板原理图

DRIVER INPUT CONNECTORS

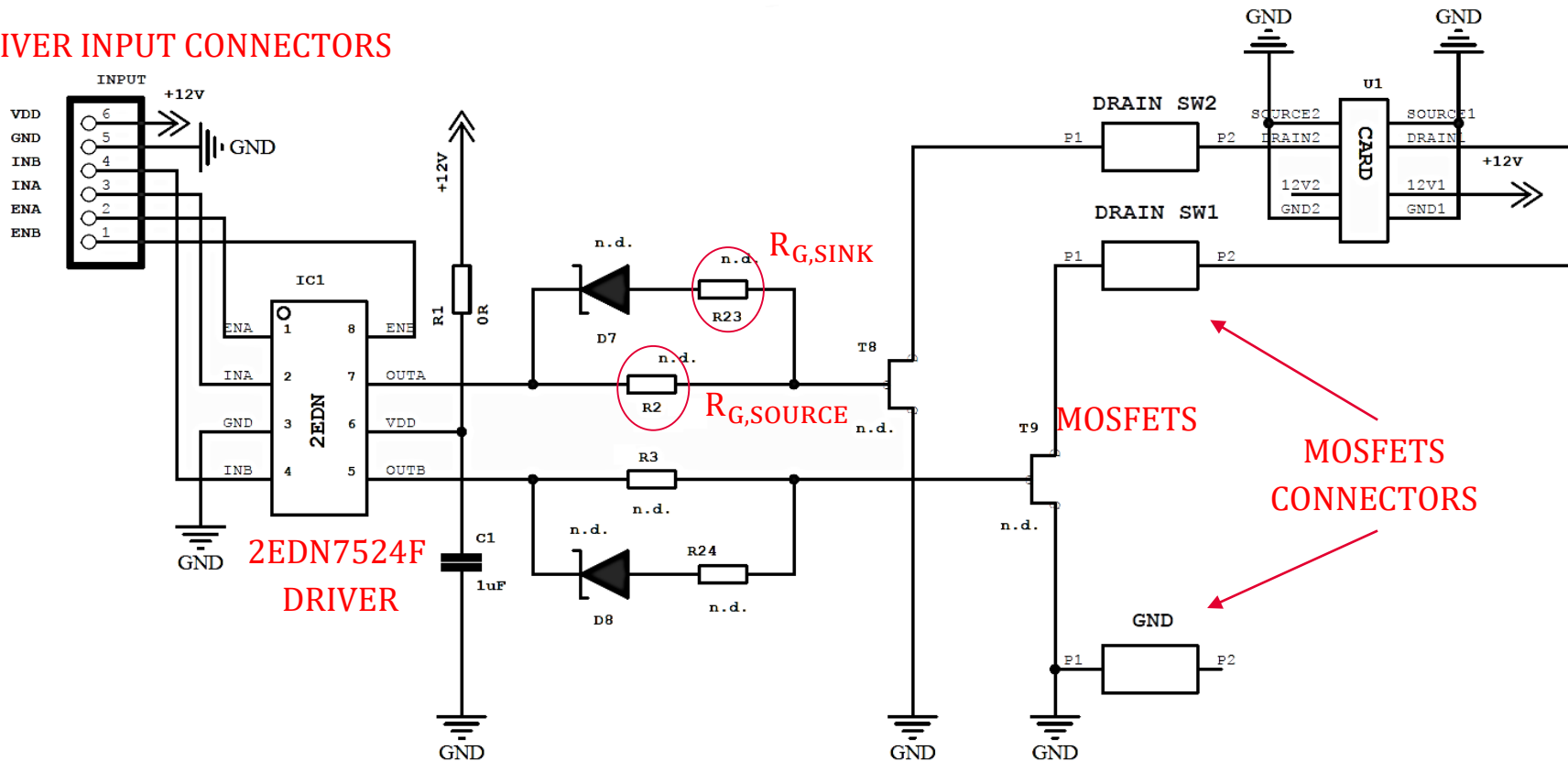



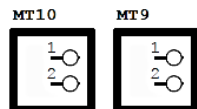
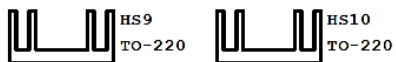

HEATSINKS

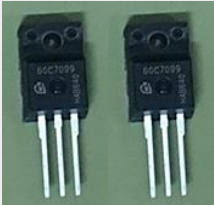

n.d.= 值未定义, 组件未装填在 PCB 上

添加组件 – BOM 建议

定距螺栓	定距螺栓的螺丝	将 MOSFET 安装到散热器的螺丝和垫圈	TO-220 插座
			

TO-220 MOSFET	拉出电阻 (R2, R3)	灌入电阻 (R23, R24)	灌入二极管
			

组件	数量	元件称号	注释	电压	器件封装	类型	零件号/耗材
灌入二极管	2	D7, D8	肖特基二极管	30 V	SOD-123	PMEG3020 肖特基二极管	816-6858 欧时电子元件 (RS-Components)
电阻	4	R2, R3, R23, R24			RES805R	SMD 陶瓷电阻	
TO-220 插座	2	T8, T9	TO-220 插座		TO-220	插座连接器 0.034" ~ 0.041" (0.86 mm ~ 1.04 mm)	5050865-5 得捷电子 (Digi-key)

第 1 步：安装定距螺栓

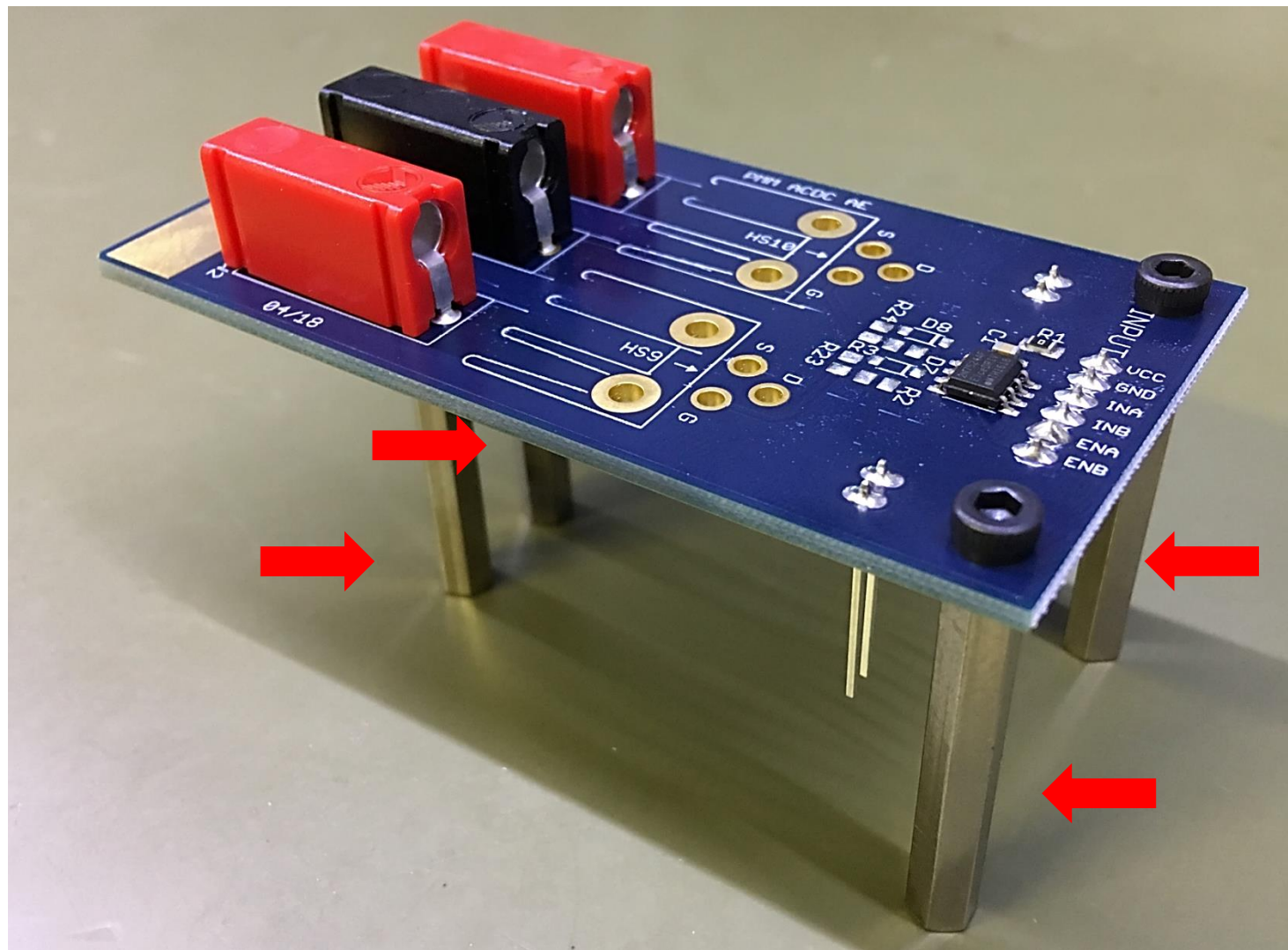

第 2 步：焊接拉出电阻

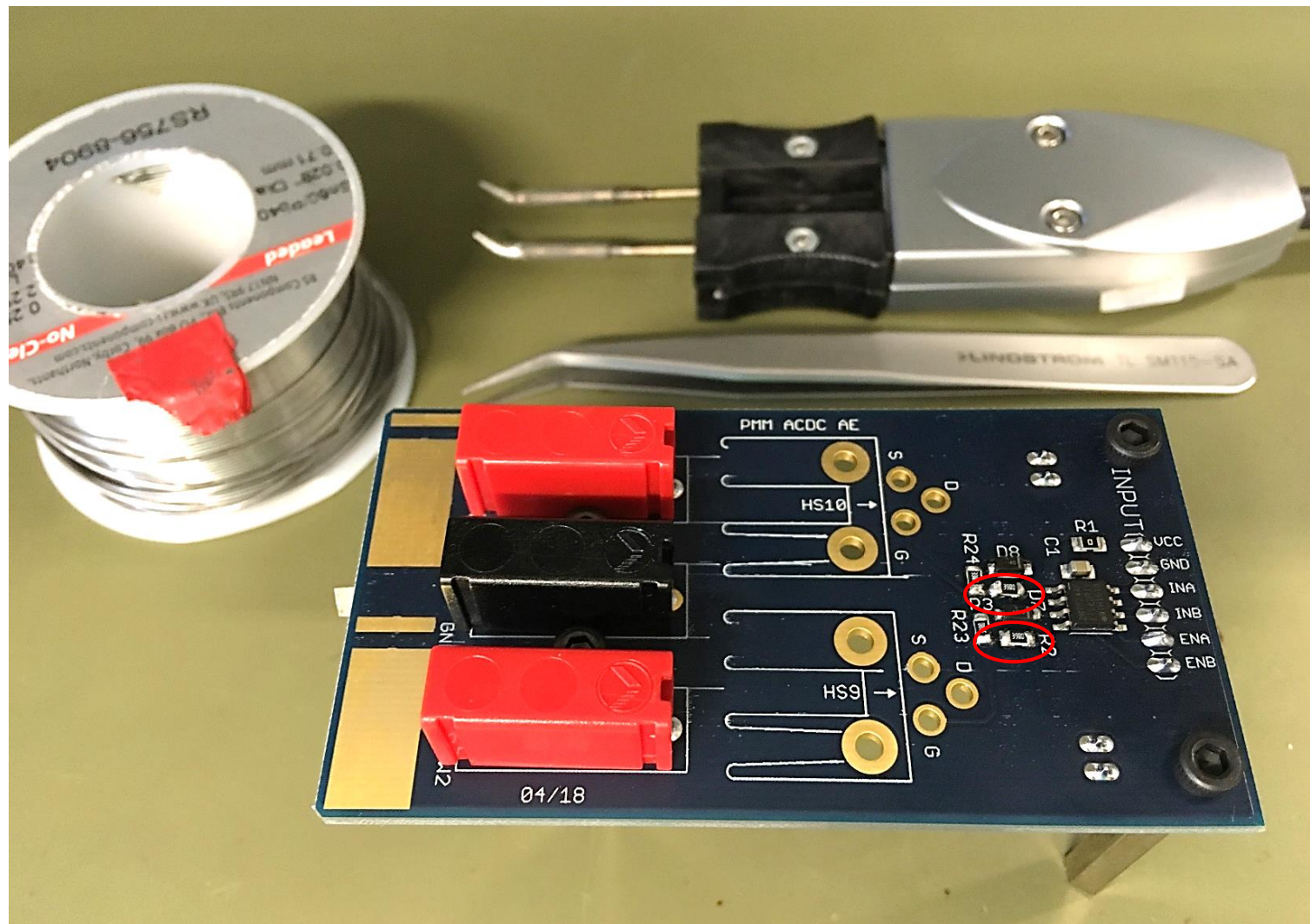

第 3 步：焊接灌入电阻和灌入二极管

- 只有在需要区分导通和关断行为时，才添加灌入电阻和灌入二极管

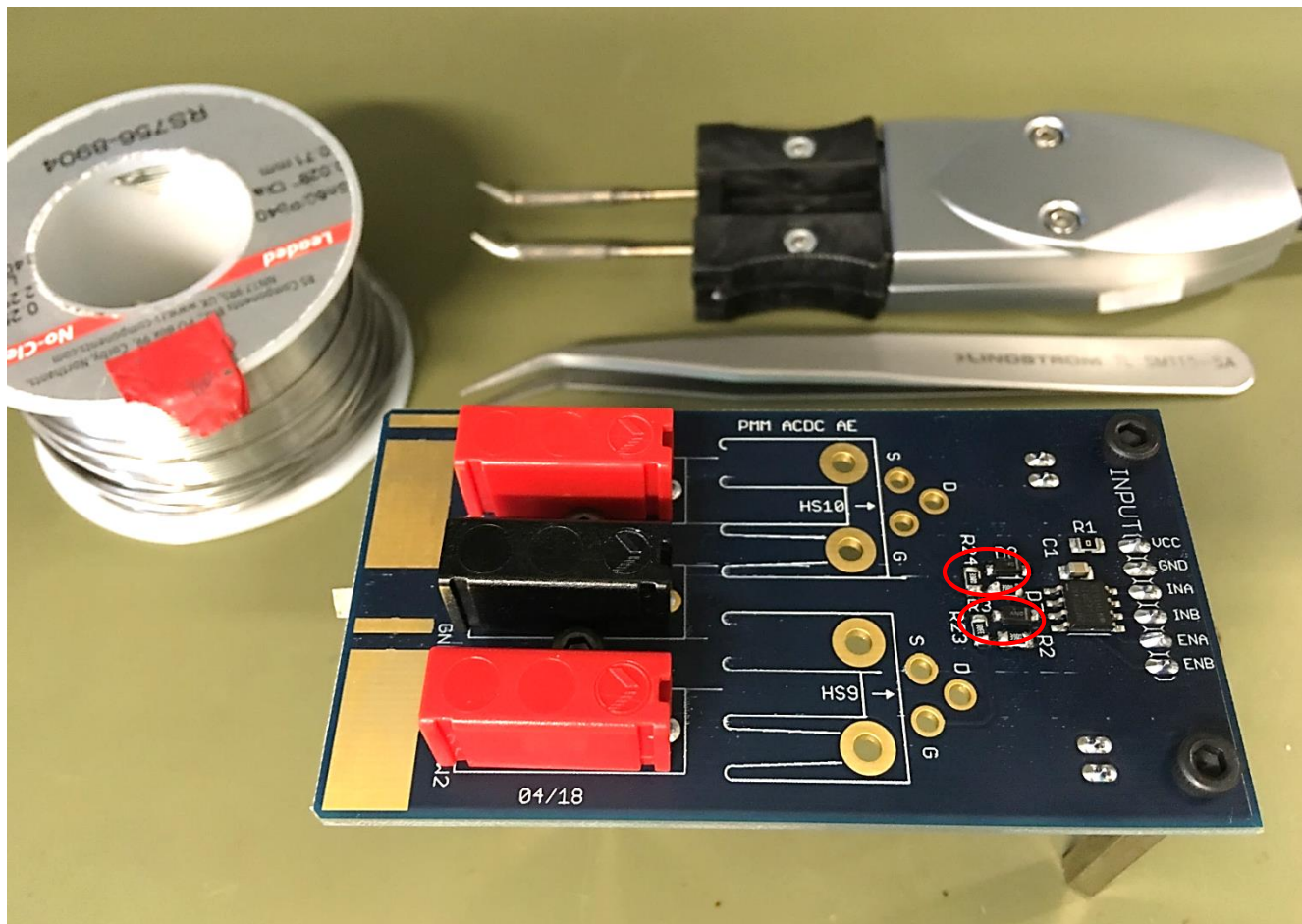

第 4 步：焊接 TO-220 插座

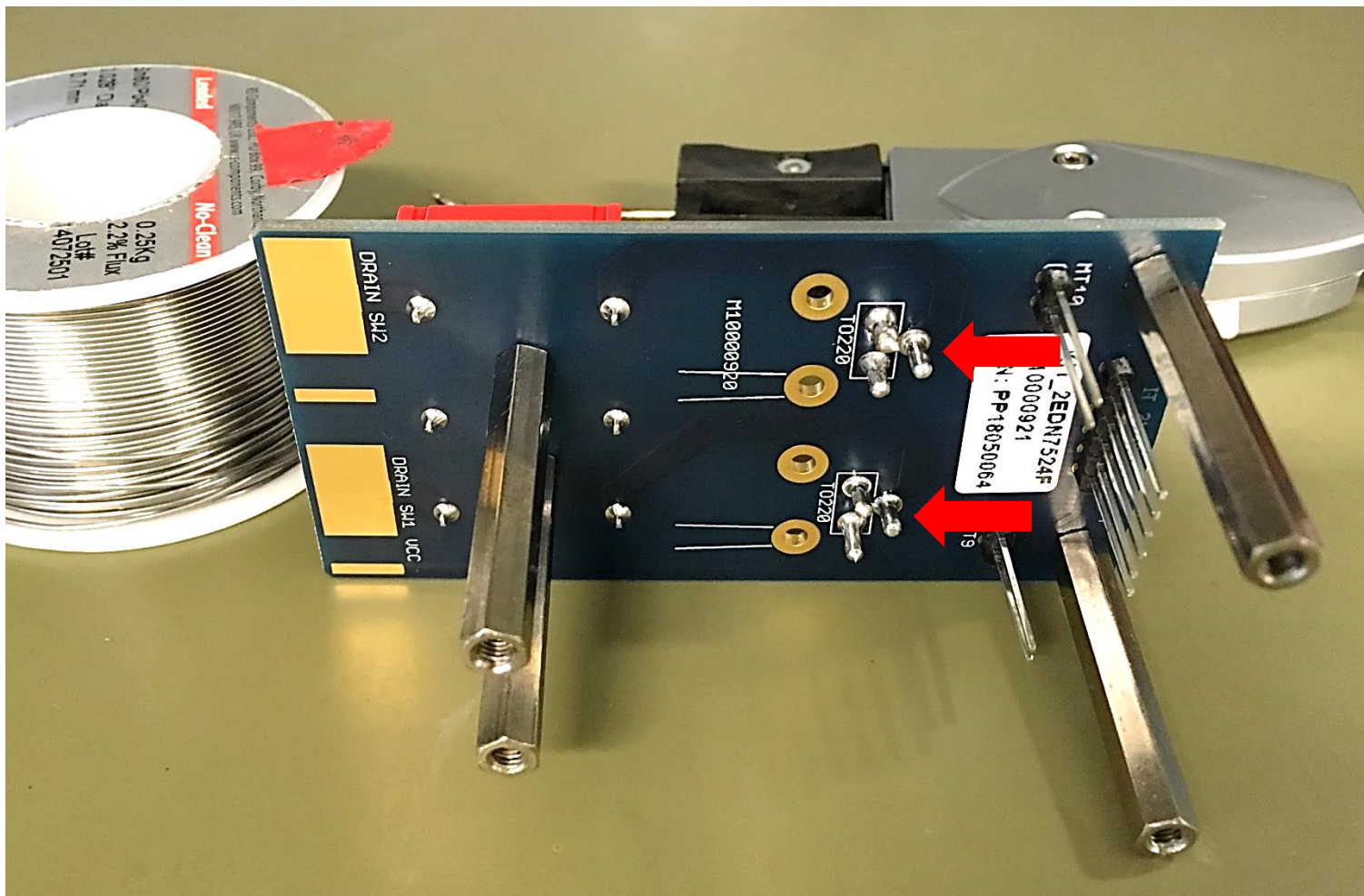

第 5 步：将 MOSFET 放置在插座中

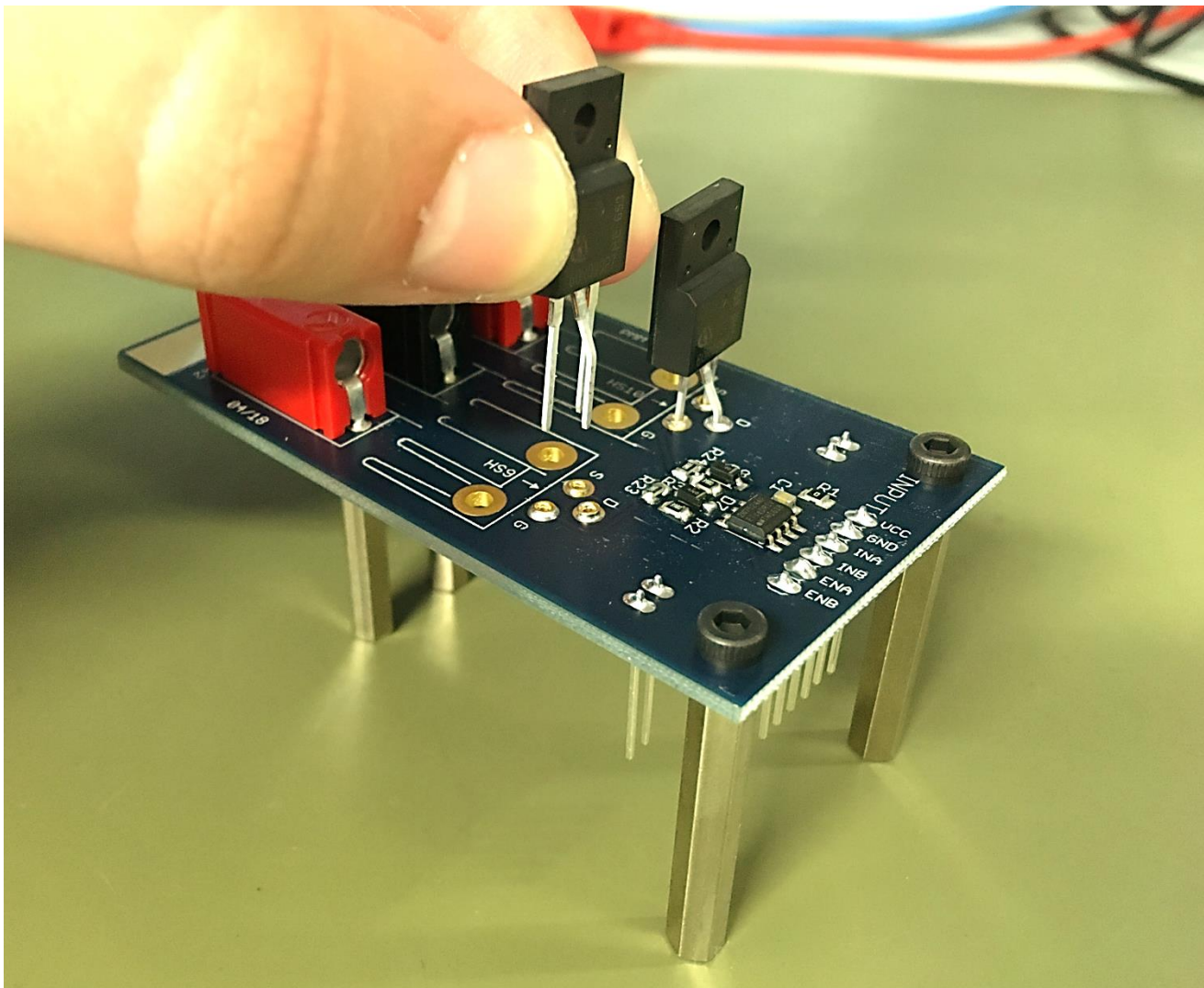

第 6 步：安装散热器（选装）

- > 如果电路板用于高压环境，请焊接散热器
- > 在基本测量中，不必如此
- > 有关如何将 MOSFET 正确安装到散热器的更多信息，请参见下一张幻灯片

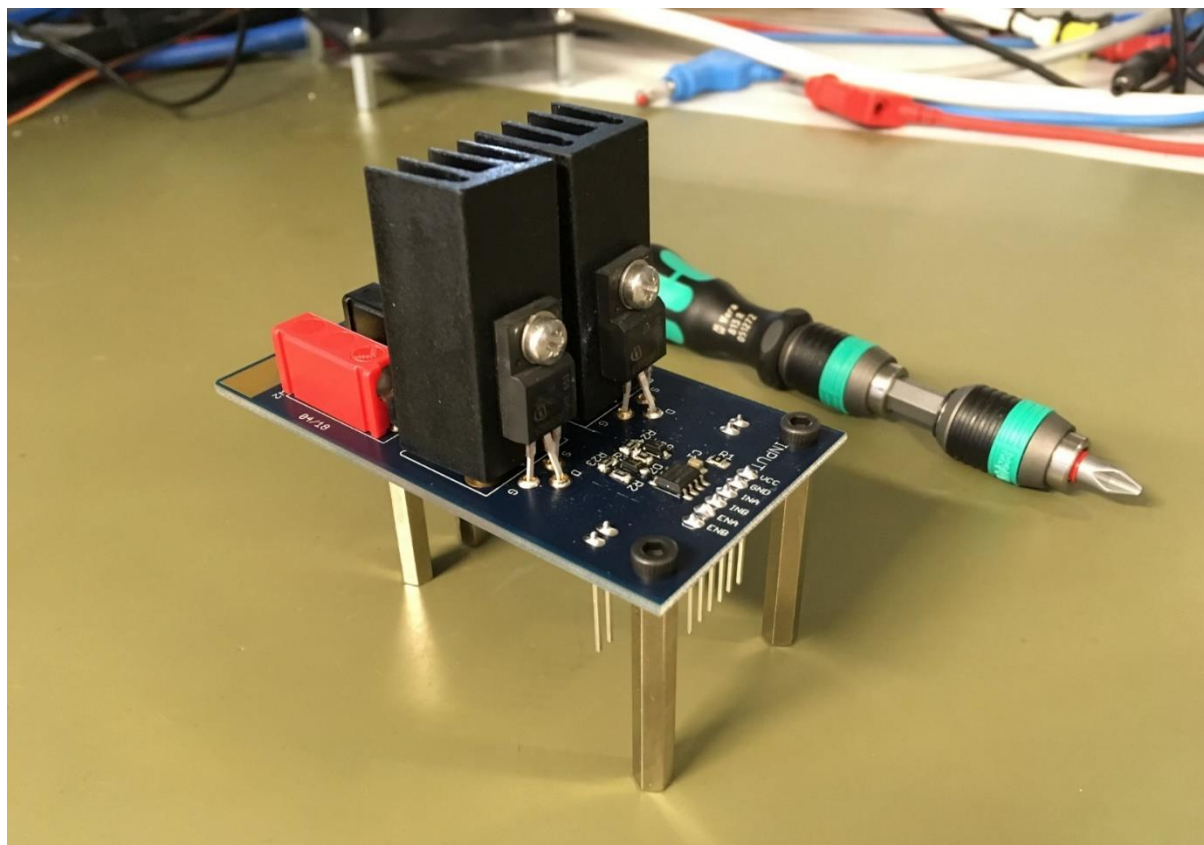

将 TO-220 MOSFET 安装到散热器

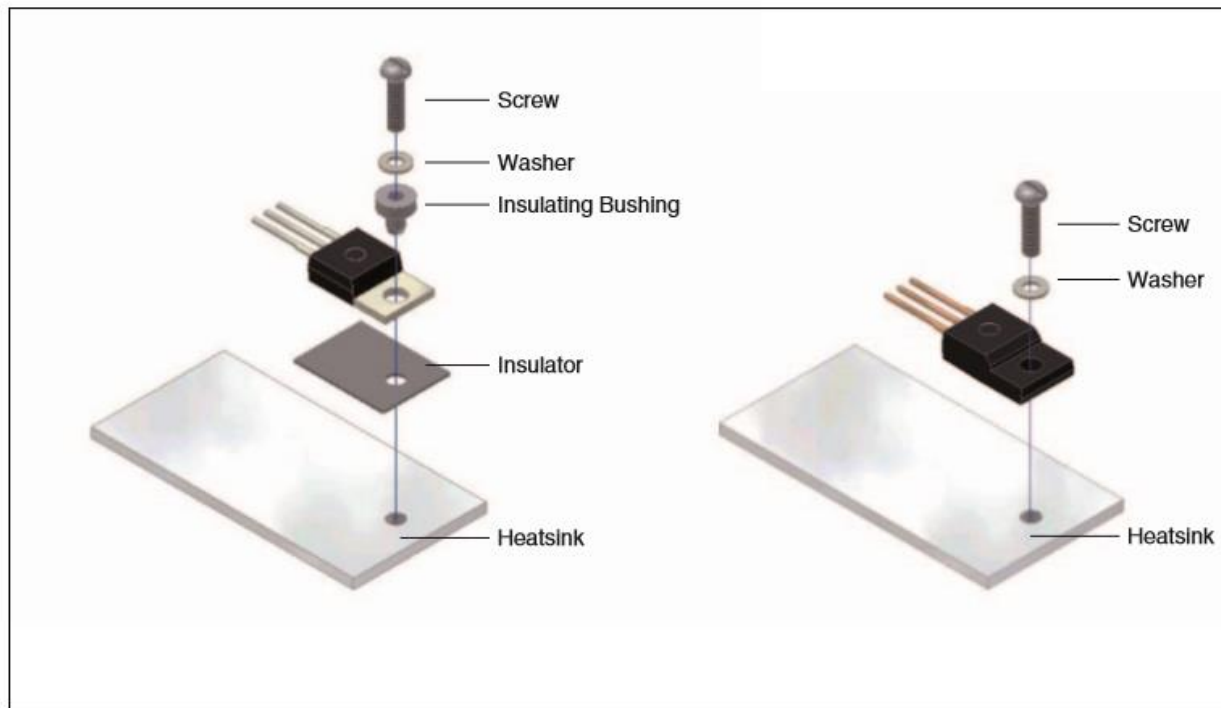

Package	Typ. Torque [Nm]	Max. Torque [Nm]	Comment
PG-TO220	0.6	0.7	Screw M3
PG-TO220 FullPAK	0.5	0.7	Screw M2.5

- > Infineon TO 包的装配建议: https://www.infineon.com/dgdl/Infineon-Package_recommendations_for_assembly_of_Infineon_TO_packages-AN-v01_00-EN.pdf?fileId=db3a30431936bc4b011938532f885a38

第 7 步：焊接 BNC 连接器

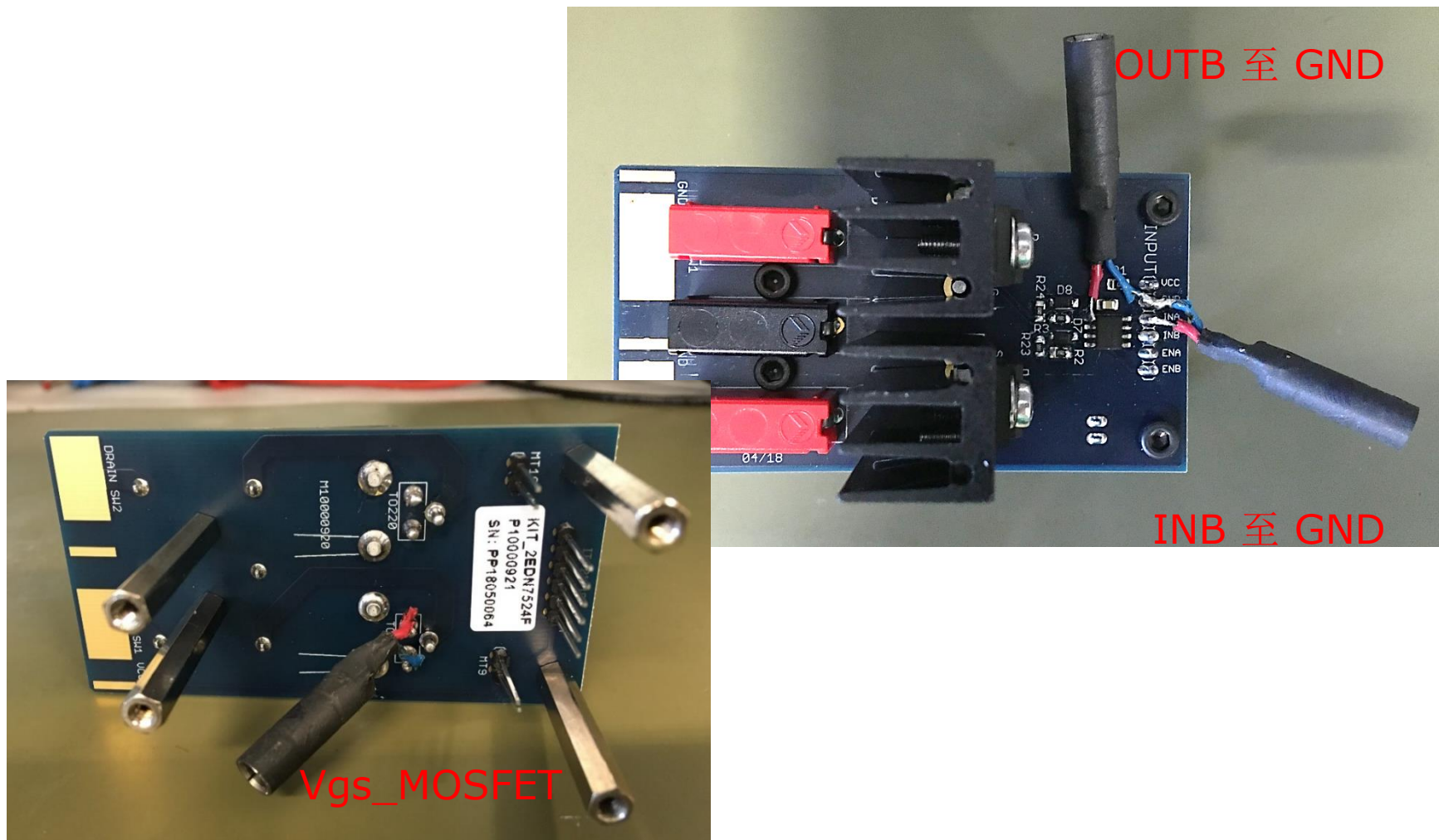

> 注：请注意，INA 和 INB 的丝印标签已合并

用于产生驱动器电源的仪表



- > CoolMOS™ 的 $V_{CC}=12\text{ V}$, OptiMOS™ 为 8 V
- > 将电流限制设置为低于 1 A (例如 0.8 A)

用于生成 PWM 信号的仪表

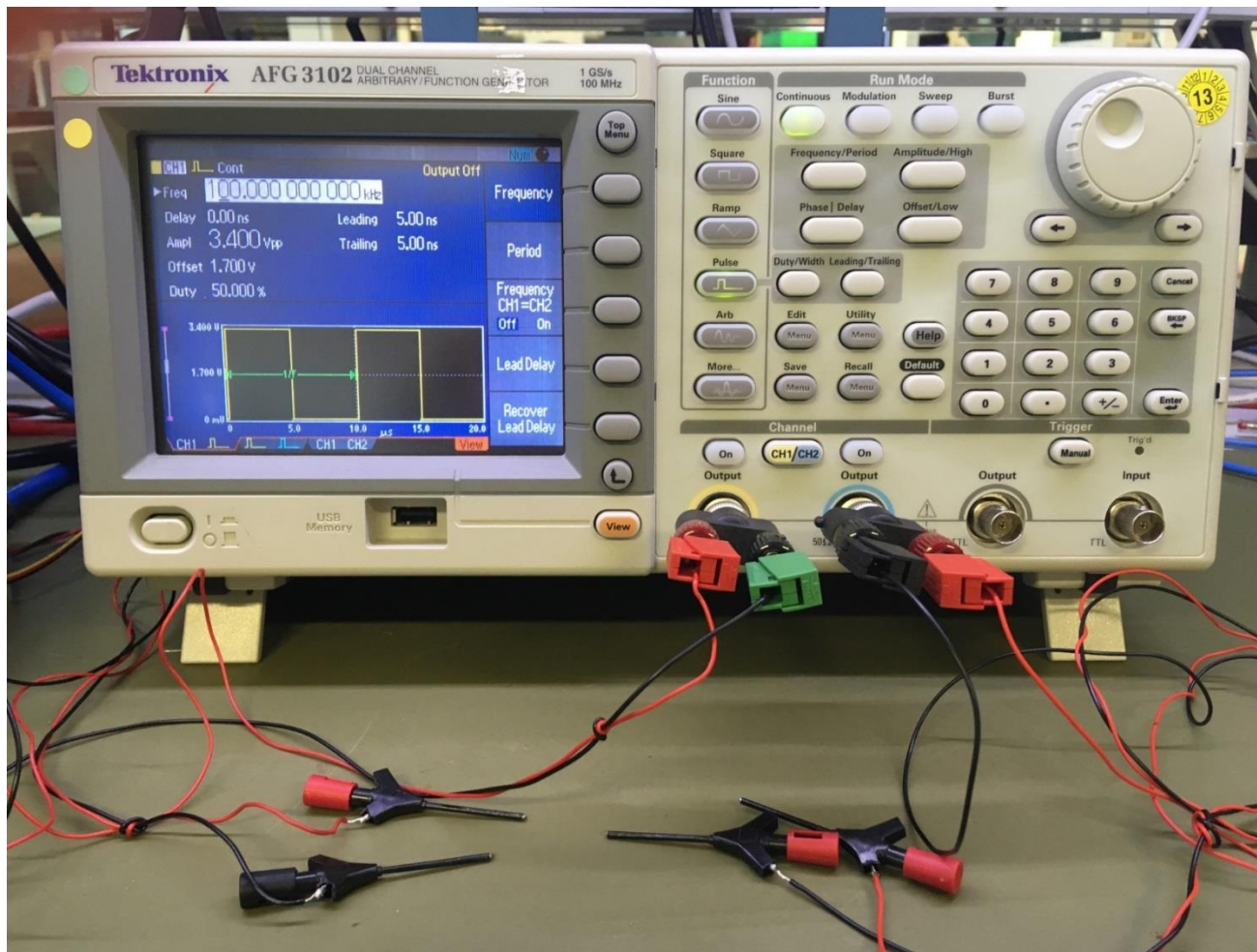

- › 使用信号发生器或微控制器

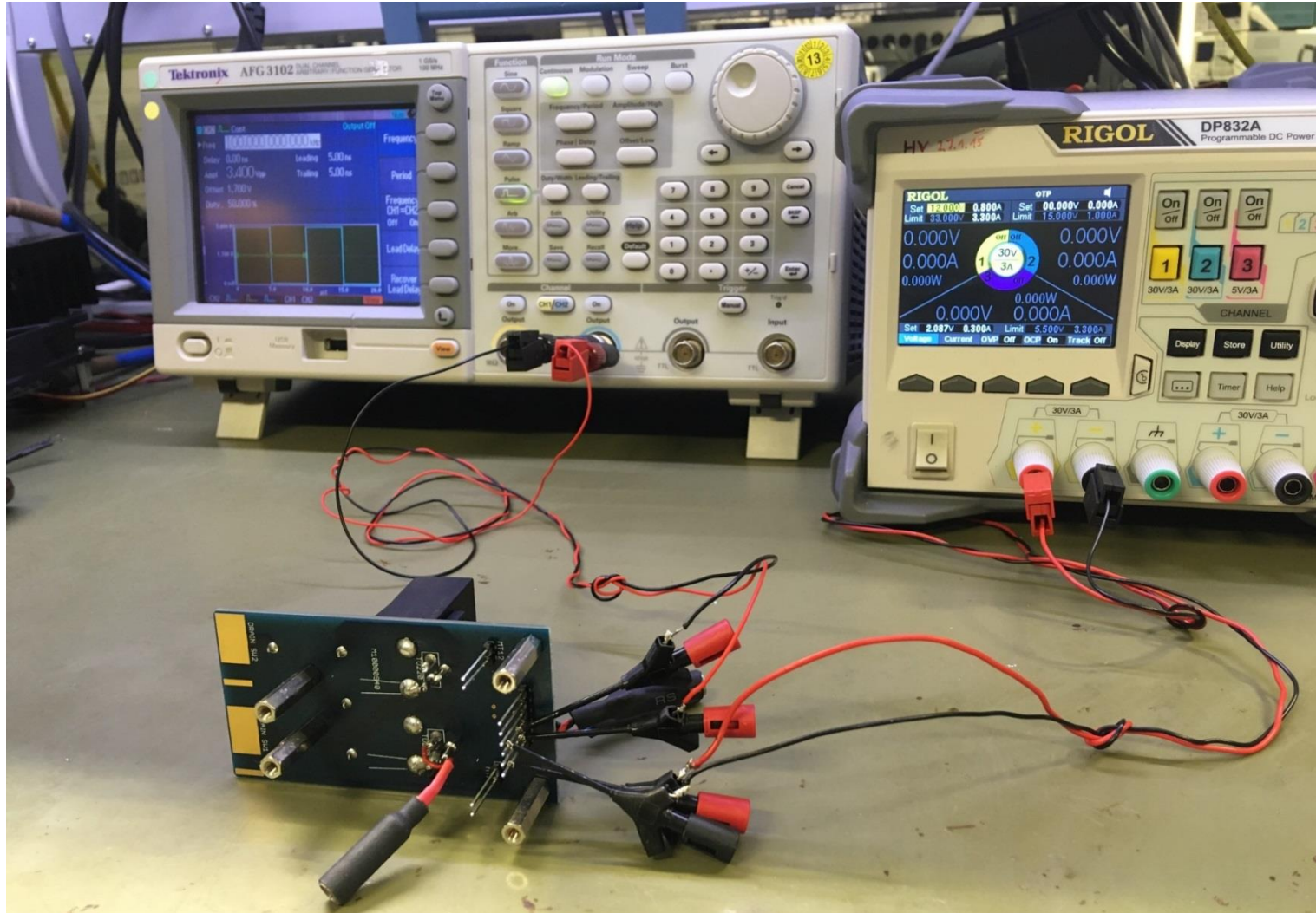

信号评估仪表

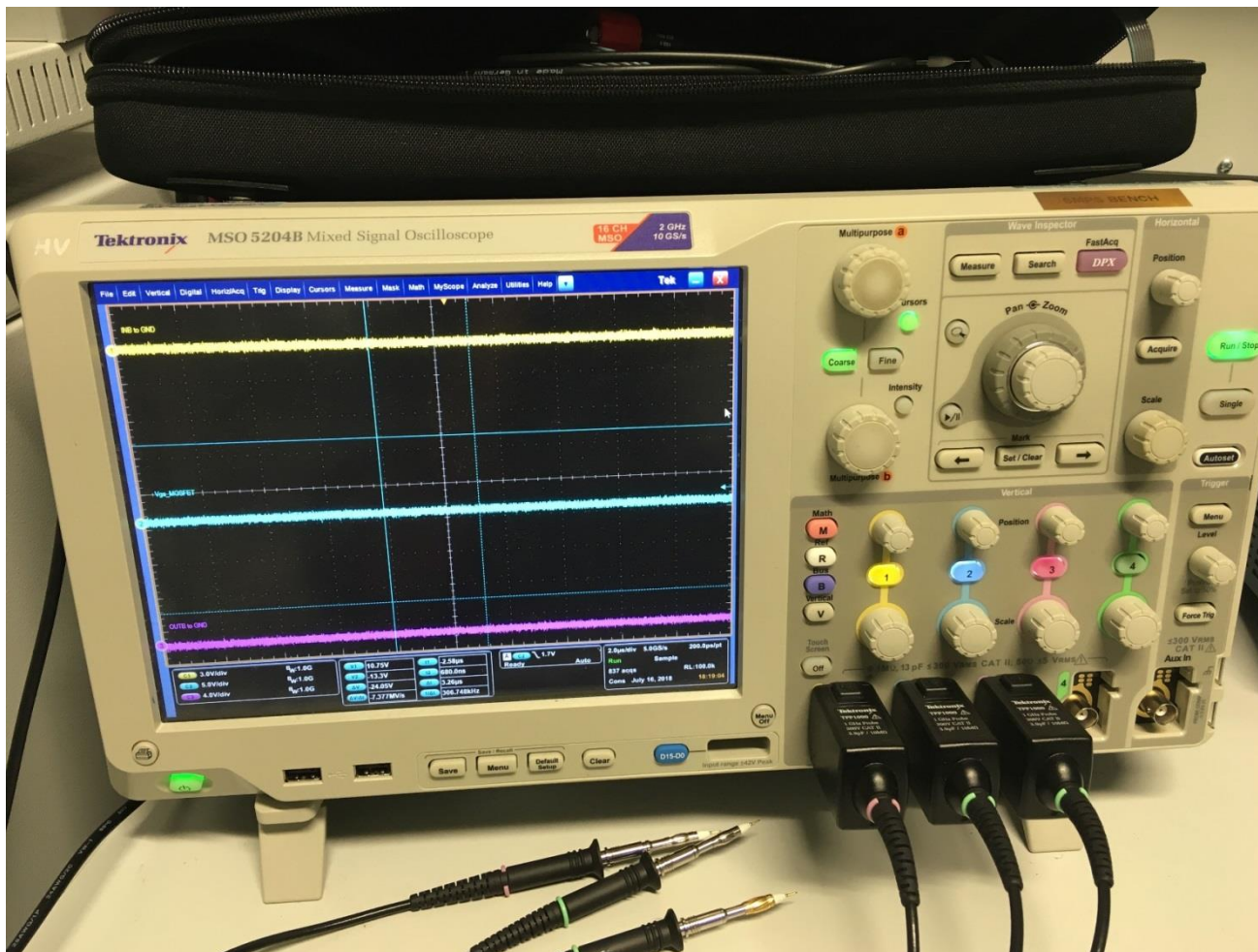

- 使用的电压探头：Tektronix TPP1000 1 GHz, 3.9 pF

完成测量设置

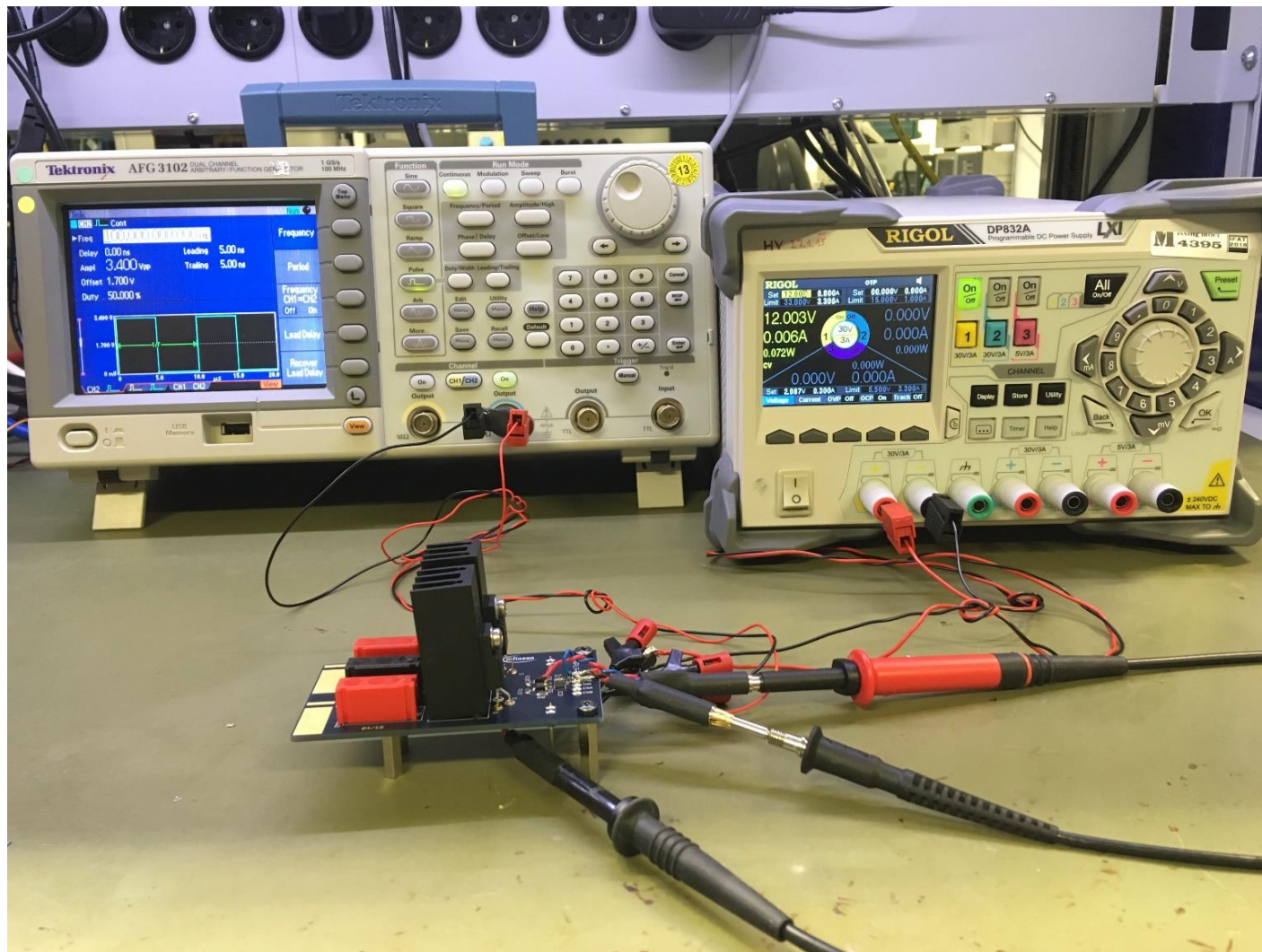

示波器波形

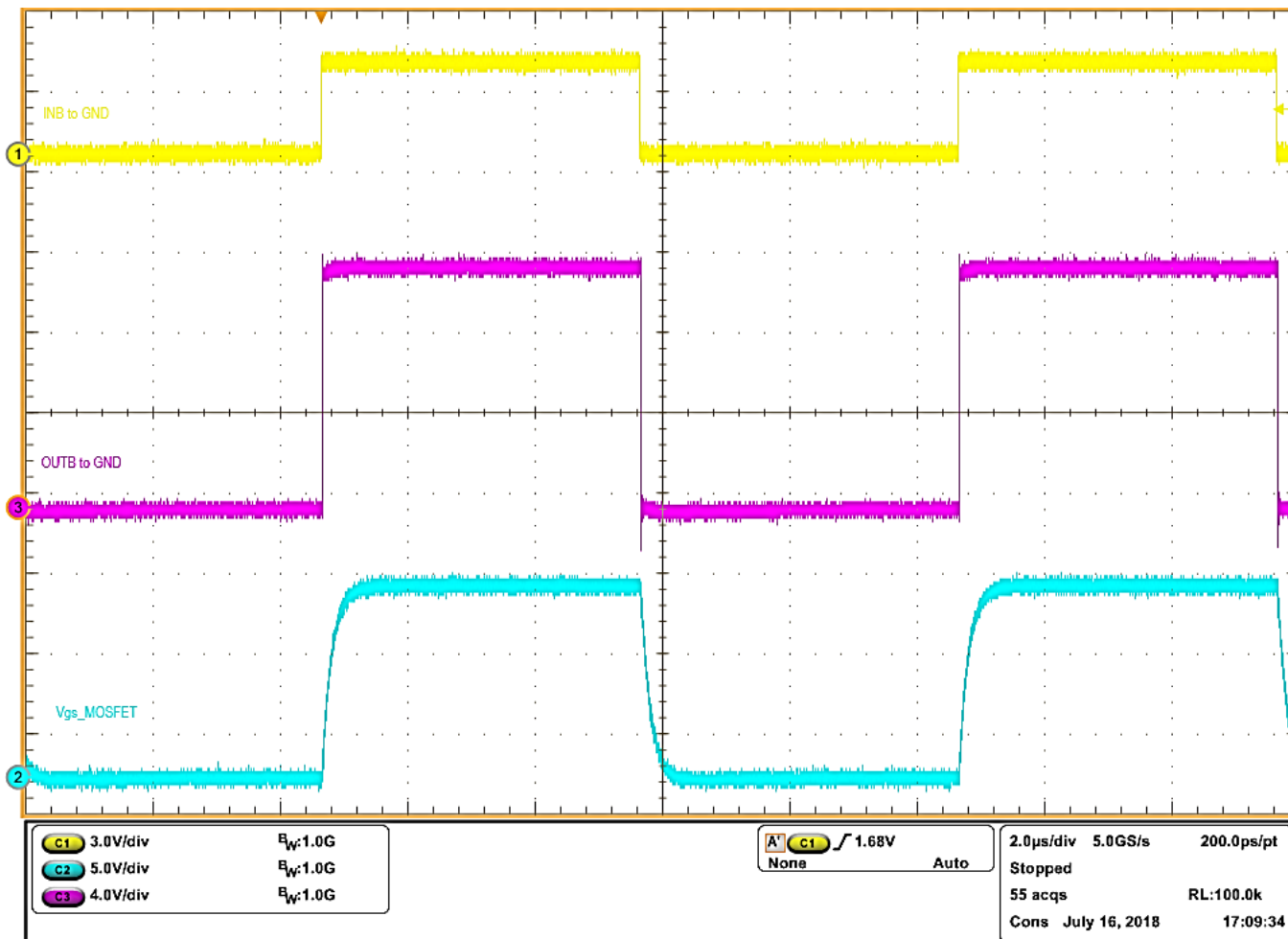

> 用在单个 MOSFET 上进行测量 $V_{DS} = 0V$ (漏极和源极短路)

驱动电路的等效模型

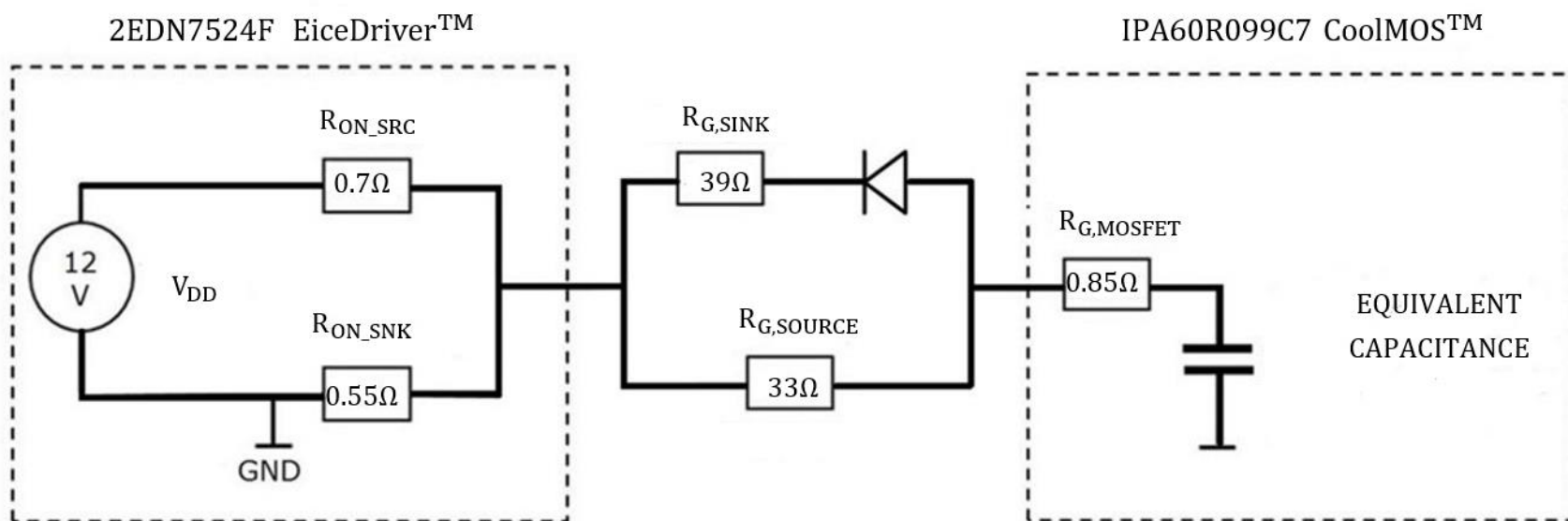

低-高传输延迟

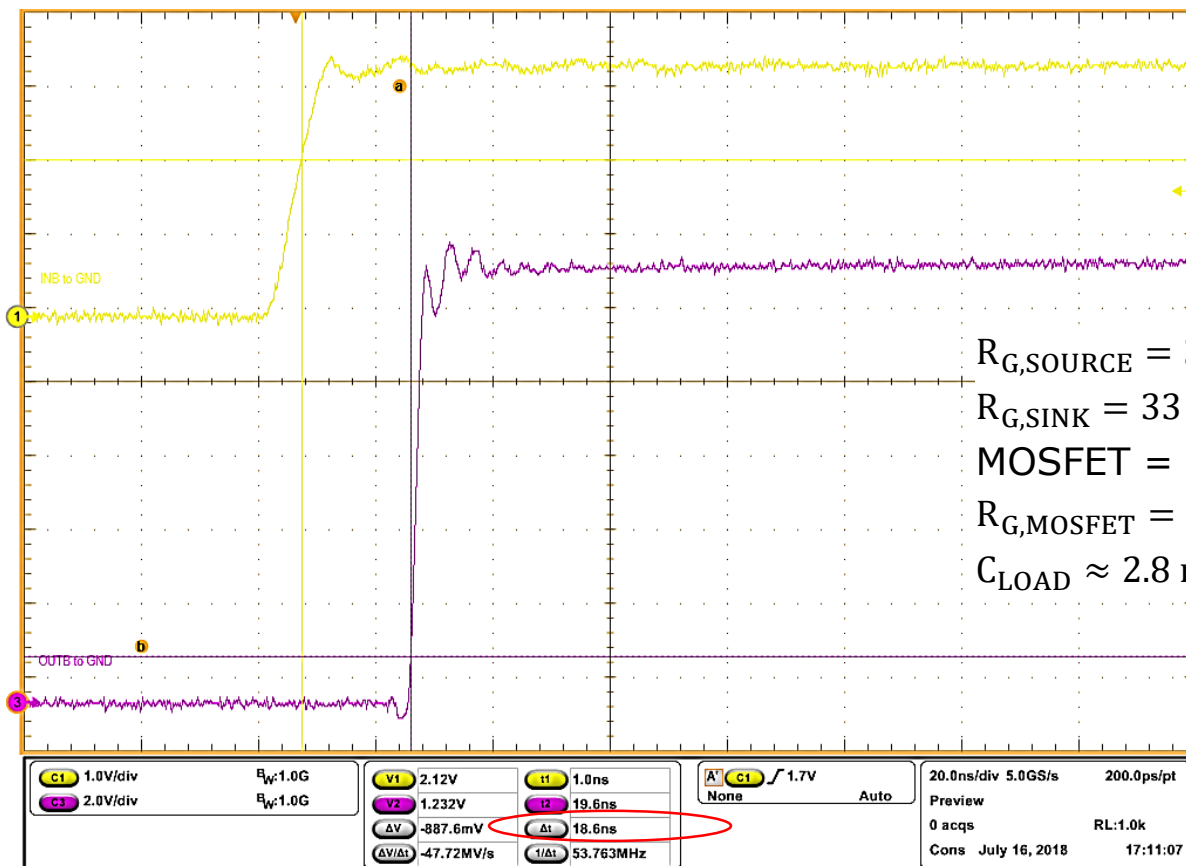

$R_{G,SOURCE} = 39 \Omega$
 $R_{G,SINK} = 33 \Omega$
MOSFET = IPA60R099C7
 $R_{G,MOSFET} = 0.82 \Omega$
 $C_{LOAD} \approx 2.8 \text{ nF}$

- > t_{PDlh} 在数据表中定义为纯电容负载的时间间隔 $t(\text{OUTB} = 10\% \text{ VDD}) - t(\text{INB} = V_{INH} = 2.1 \text{ V})C_{LOAD} = 1.8 \text{ nF}$ $R_{G,SOURCE} = 0 \Omega$
- > 注：在所考虑的测量中，负载是 $R_{G,MOSFET} = 0.82 \Omega$ 、 $R_{G,SOURCE} = 39 \Omega$ 、 $C_{LOAD} \approx 2.8 \text{ nF}$ 的晶体管（参见幻灯片 23 页的数据进行 C_{LOAD} 计算）

高-低传输延迟

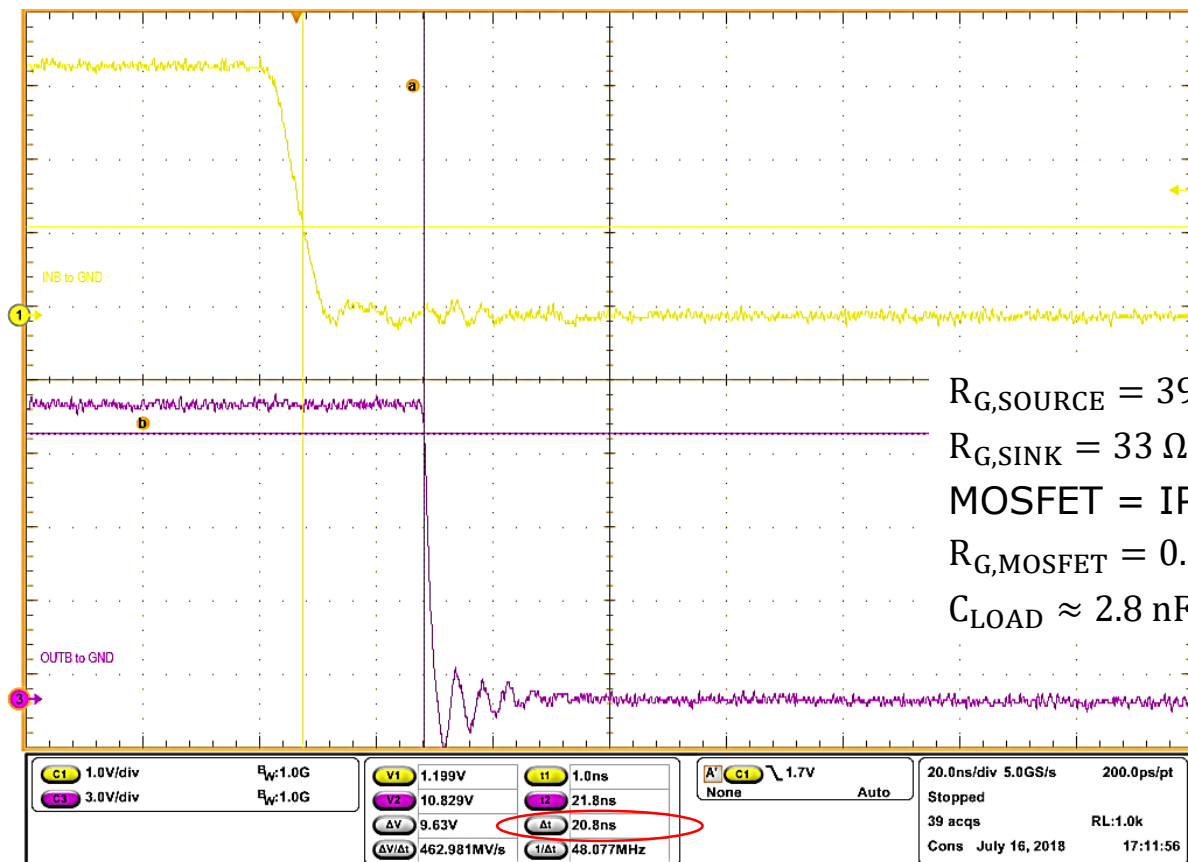

$R_{G,SOURCE} = 39 \Omega$
 $R_{G,SINK} = 33 \Omega$
MOSFET = IPA60R099C7
 $R_{G,MOSFET} = 0.82 \Omega$
 $C_{LOAD} \approx 2.8 \text{ nF}$

- > t_{PDhl} 在数据表中定义为纯电容负载的时间间隔 $t(\text{OUTB} = 90\% \text{ VDD}) - t(\text{INB} = V_{INL} = 1.02 \text{ V})C_{LOAD} = 1.8 \text{ nF}R_{G,SINK} = 0 \Omega$
- > 注：在所考虑的测量中，负载是 $R_{G,MOSFET} = 0.82 \Omega$ ， $R_{G,SINK} = 33 \Omega$ ， $C_{LOAD} \approx 2.8 \text{ nF}$ 的晶体管

IPA60R099C7, C_{LOAD} 计算



Gate to drain charge	Q_{gd}	-	14	-	nC	$V_{DD}=400V, I_D=9.7A, V_{GS}=0 \text{ to } 10V$
Gate charge total	Q_g	-	42	-	nC	$V_{DD}=400V, I_D=9.7A, V_{GS}=0 \text{ to } 10V$

$$Q_{LOAD} = Q_g - Q_{gd} = 28 \text{ nC} \rightarrow C_{LOAD} = \frac{Q_{LOAD}}{V_{GS}} = 2.8 \text{ nF} \text{ for } V_{GS} = 10 \text{ V} \rightarrow$$

$$C_{LOAD} \approx 2.8 \text{ nF} \text{ for } V_{GS} = 12 \text{ V}$$

升/降时间

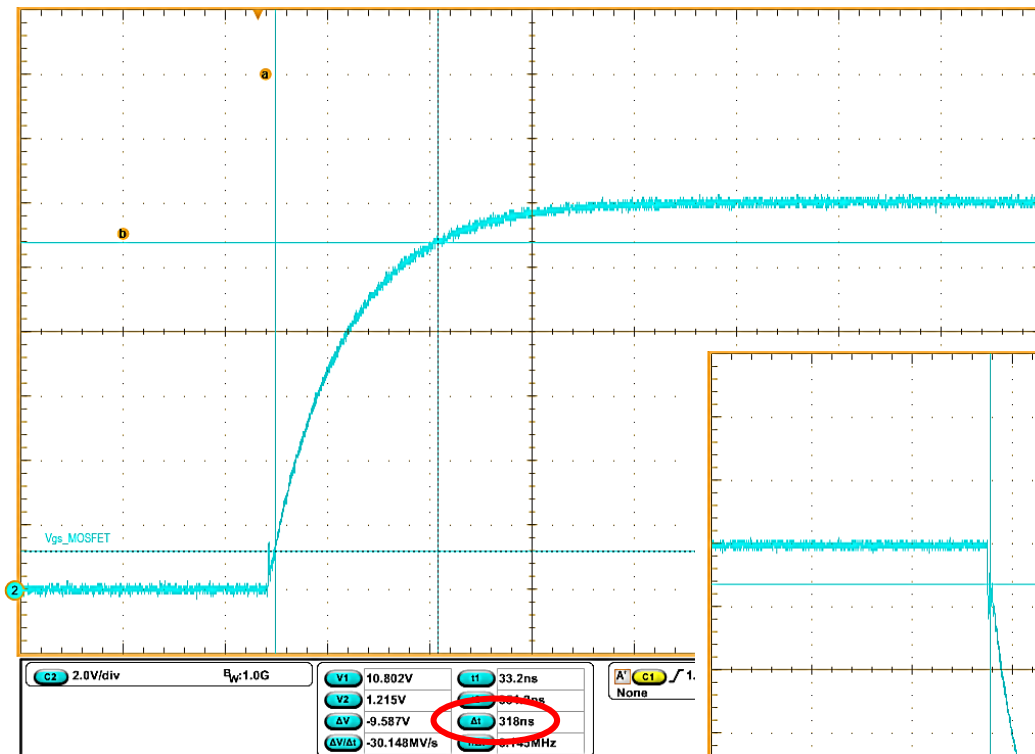

$$R_{G,SOURCE} = 39 \Omega$$

$$R_{G,SINK} = 33 \Omega$$

MOSFET = IPA60R099C7

$$R_{G,MOSFET} = 0.82 \Omega$$

$$C_{LOAD} \approx 2.8 \text{ nF}$$

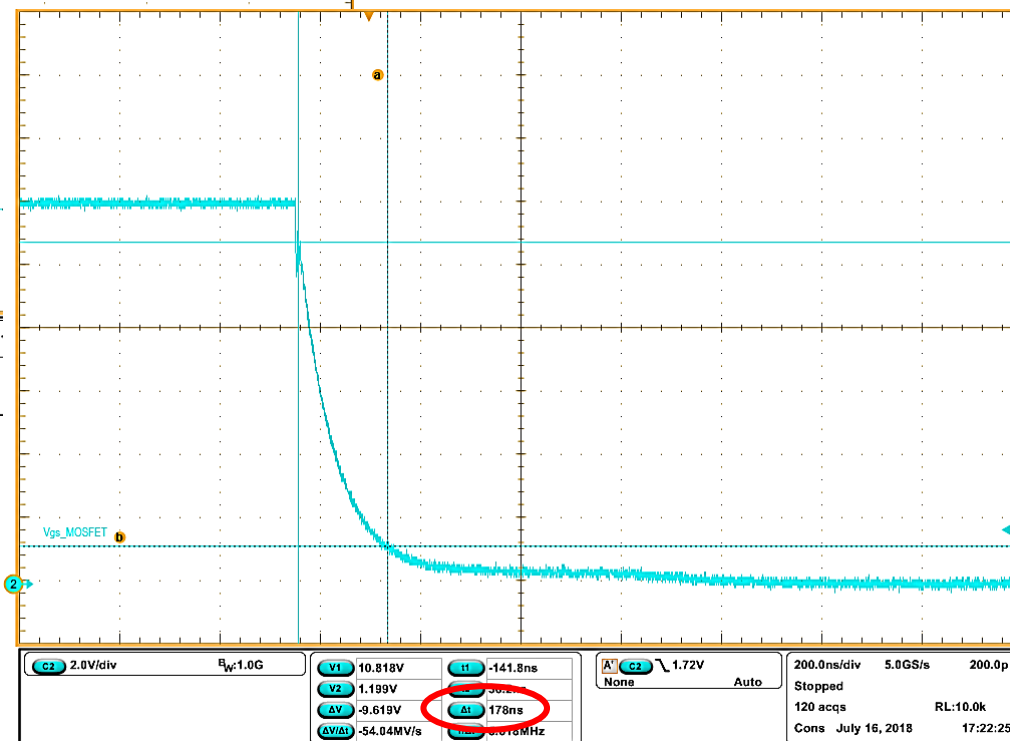

栅极电阻更换

$$R_{G,SOURCE} = 39 \Omega \quad \rightarrow \quad 24 \Omega$$

$$R_{G,SINK} = 33 \Omega \quad \rightarrow \quad 20 \Omega$$

MOSFET = IPA60R099C7

升/降时间：新的栅极阻值设置

$R_{G,SOURCE} = 24 \Omega$
 $R_{G,SINK} = 20 \Omega$
 MOSFET = IPA60R099C7
 $R_{G,MOSFET} = 0.82 \Omega$
 $C_{LOAD} \approx 2.8 \text{ nF}$

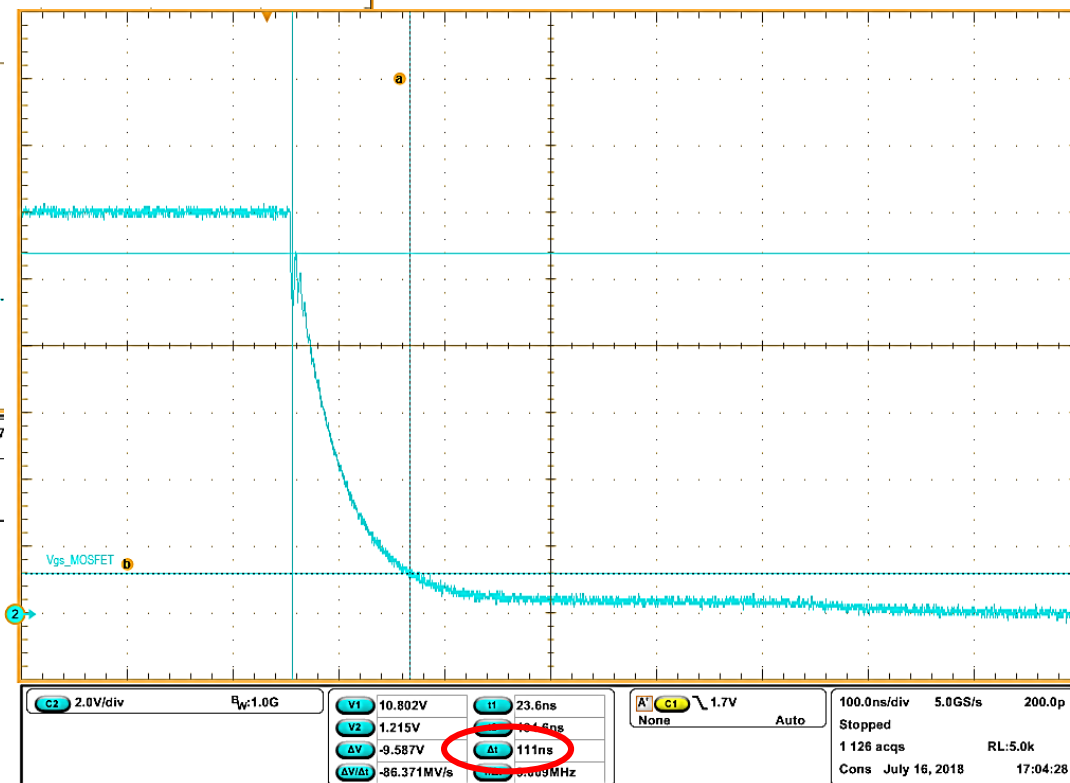
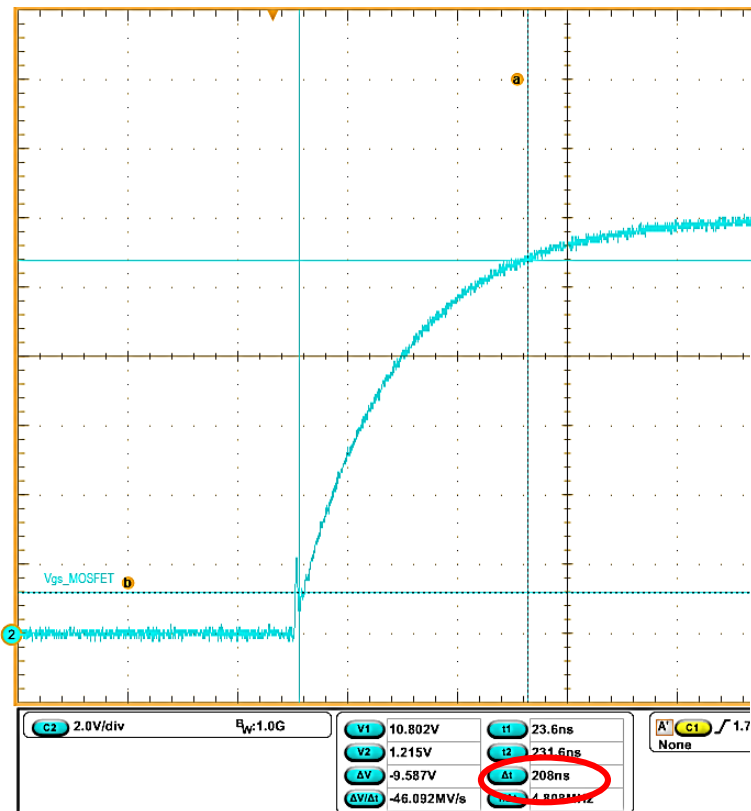

栅极电阻更换

$$R_{G,SOURCE} = 24 \Omega \quad \rightarrow \quad 51 \Omega$$

$$R_{G,SINK} = 20 \Omega \quad \rightarrow \quad 43 \Omega$$

MOSFET = IPA60R099C7

升/降时间：新的栅极阻值设置

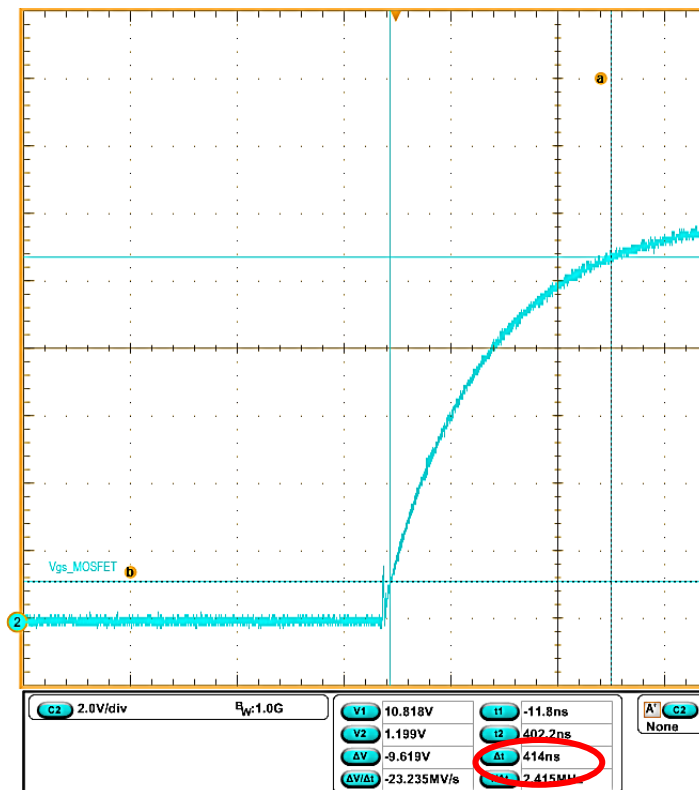

$R_{G,SOURCE} = 51 \Omega$
 $R_{G,SINK} = 43 \Omega$
 MOSFET =
 IPA60R099C7
 $R_{G,MOSFET} = 0.82 \Omega$
 $C_{LOAD} \approx 2.8 \text{ nF}$

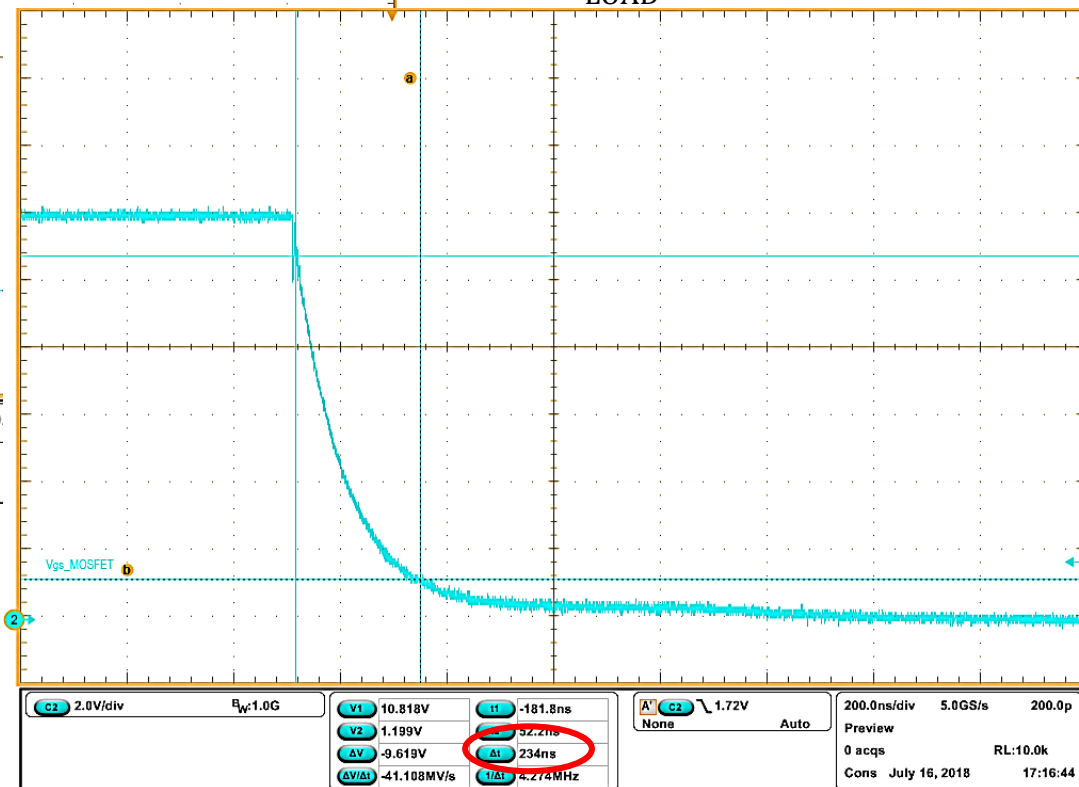

MOSFET 更换

IPA60R099C7 → IPA60R280CFD7

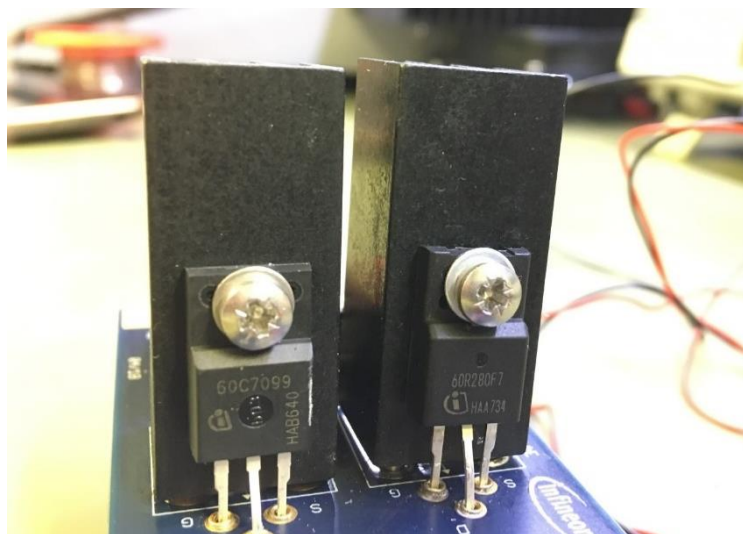

Gate to drain charge	Q_{gd}	-	5	-	nC	$V_{DD}=400V, I_D=5.0A, V_{GS}=0 \text{ to } 10V$
Gate charge total	Q_g	-	18	-	nC	$V_{DD}=400V, I_D=5.0A, V_{GS}=0 \text{ to } 10V$

$$C_{LOAD} \approx \frac{13 \text{ nC}}{10 \text{ V}} = 1.3 \text{ nF for } V_{GS} = 12 \text{ V}$$

升/降时间：新 MOSFET

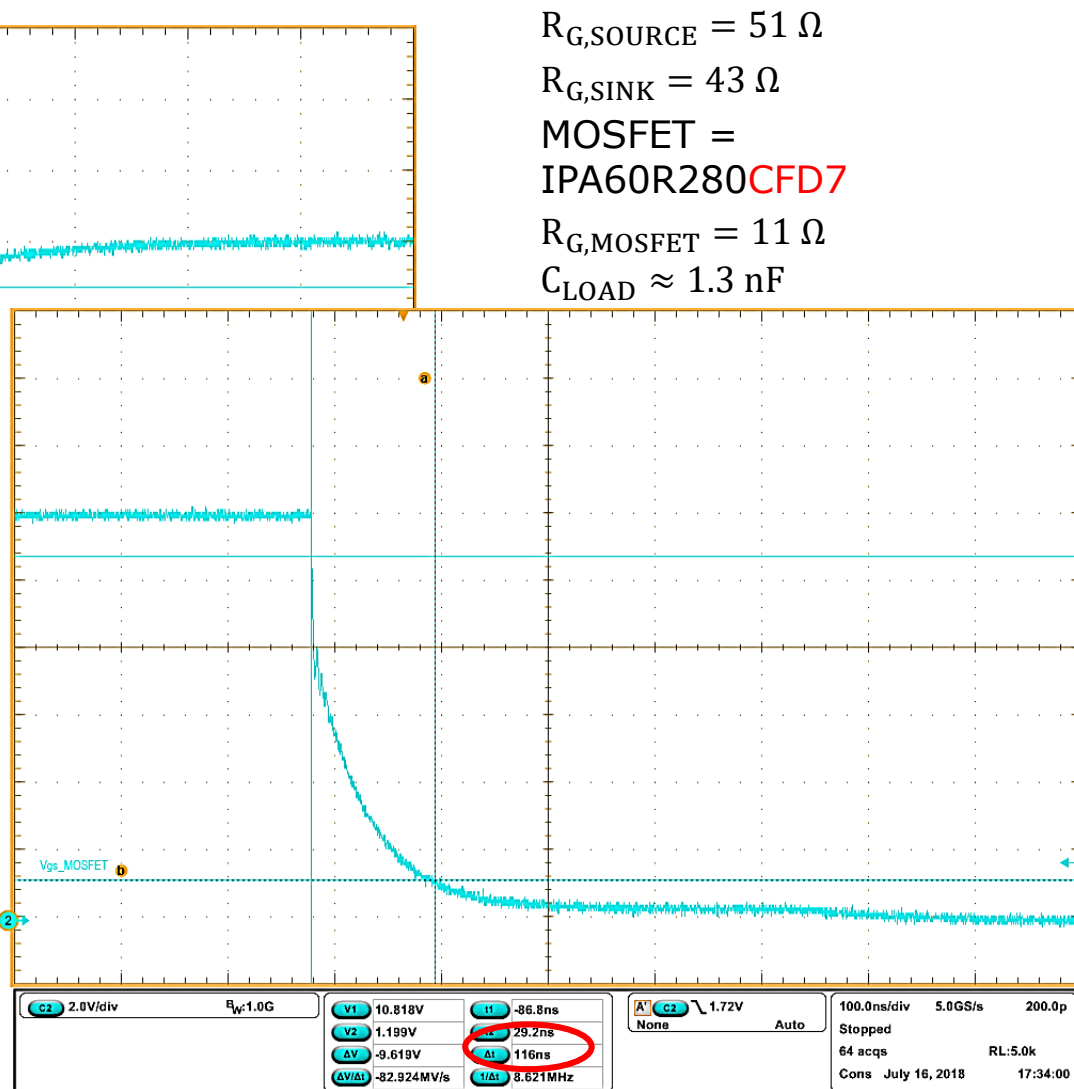
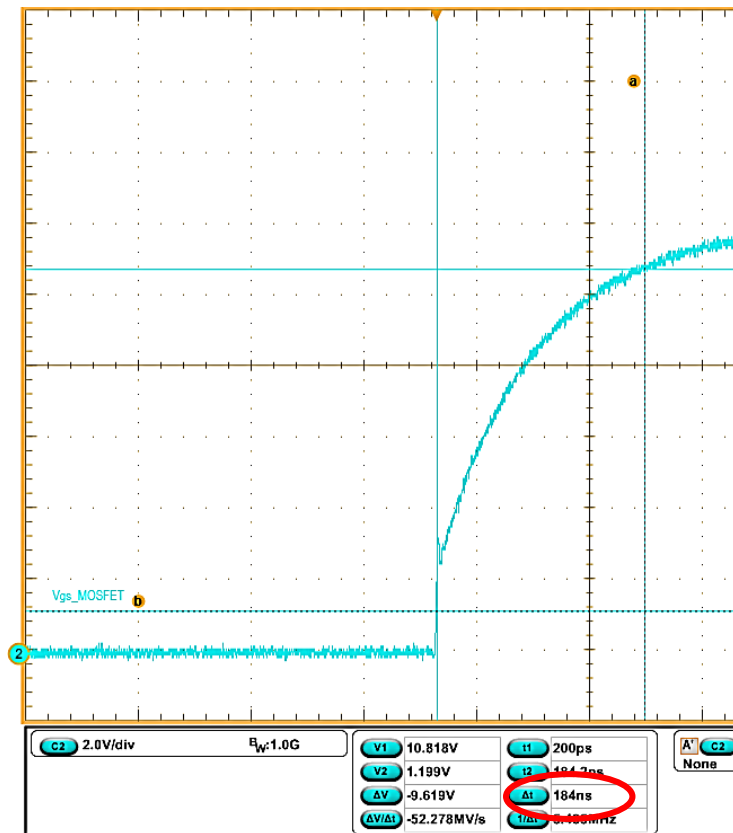

MOSFET 更换

IPA60R280CFD7 → IPA60R180P7

Gate to drain charge	Q _{gd}	-	8	-	nC	V _{DD} =400V, I _D =5.6A, V _{GS} =0 to 10V
Gate charge total	Q _g	-	25	-	nC	V _{DD} =400V, I _D =5.6A, V _{GS} =0 to 10V

$$C_{LOAD} \approx \frac{19 \text{ nC}}{10 \text{ V}} = 1.9 \text{ nF for } V_{GS} = 12 \text{ V}$$

升/降时间：新 MOSFET

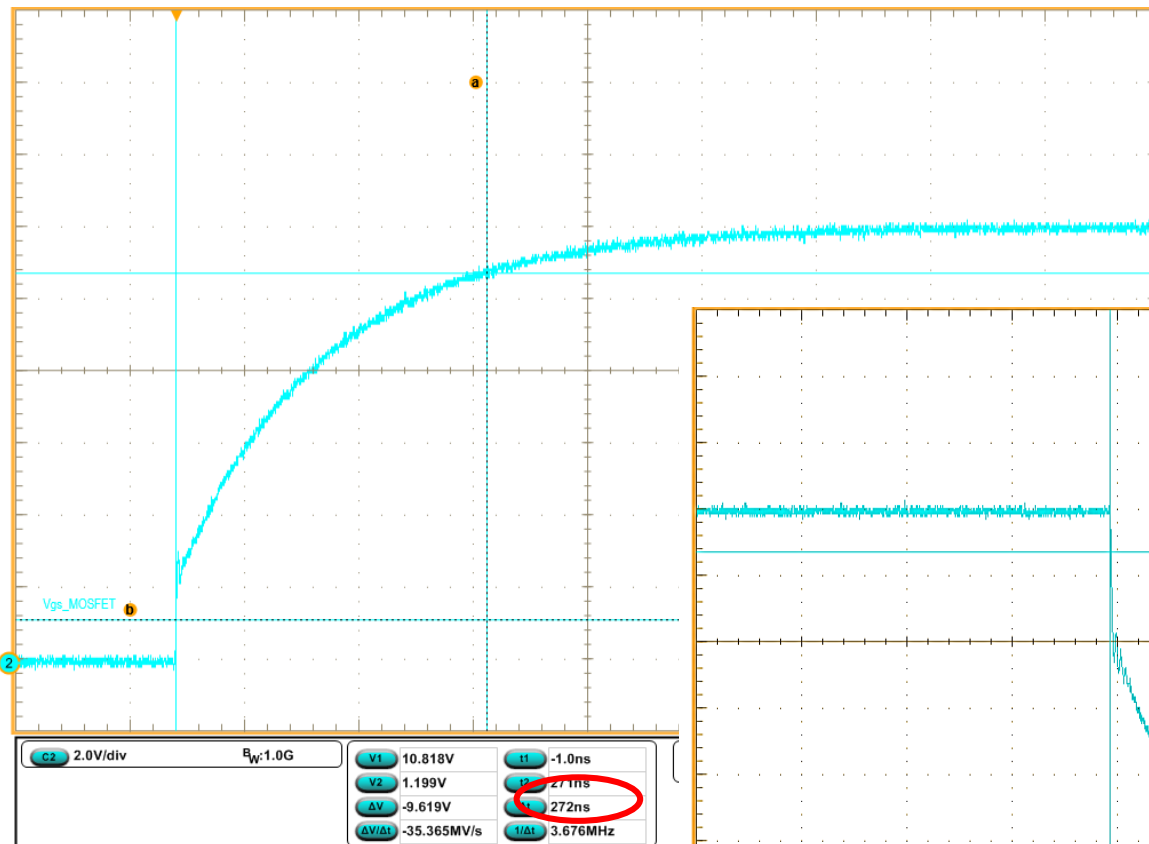

$R_{G,SOURCE} = 51 \Omega$
 $R_{G,SINK} = 43 \Omega$
MOSFET = IPA60R180P7
 $R_{G,MOSFET} = 11 \Omega$
 $C_{LOAD} \approx 1.9 \text{ nF}$

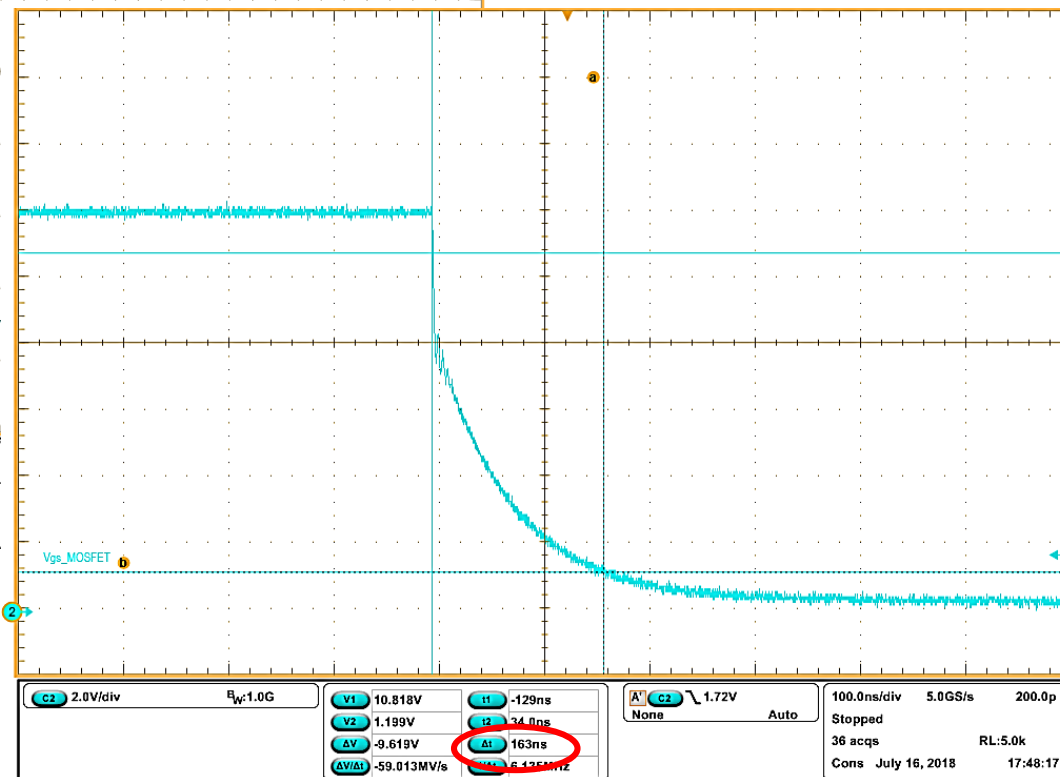

其他说明

- > 请注意，MOSFET 没有导通或关断，您只是在给栅极到源极电容进行充电/放电
- > 更改栅极电阻和 MOSFET，即会改变驱动器的负载
- > 如果要导通或关断 MOSFET，必须将电路板集成到适当的电路中
- > 不能通过电路板上的香蕉插头直接在 MOSFET 上施加电压（如 400V）
- > 您必须限制来自直流电源发生器的输入电流→增加一个电感
- > 当 MOSFET 关断时，您必须为电流创建续流路径

示例：升压转换器，钳位磁感应模式下的简单 MOSFET

重要通知和警告

重要通知

在任何情况下，本文档中所提供的信息均不应被视为针对条件或品质做出的保证 (“**Beschaffenhheitsgarantie**”)。

对于本文档中所述的任何示例、提示或任何典型值及/或有关产品应用的任何信息，英飞凌科技对此不承担任何及所有形式的保证和责任，包括但不限于其不侵犯任何第三方知识产权的保证，特此声明。

此外，本文档中的任何信息均取决于客户履行本文档所载明的义务，及客户产品以及客户对于英飞凌产品的应用相关的任何法律要求、规范和标准。

本文档中的数据仅供接受了技术培训的员工使用。客户的技术部门有责任评估产品是否适合预期应用，以及本文档中有关此类应用的产品信息的完整性。若需获得有关产品、技术、交付条款与条件和价格的更多信息，请联系距离您最近的英飞凌办事处 (www.infineon.com)。

警告

由于技术要求，产品可能包含有害物质。若需了解相关物质的类型，请联系距离您最近的英飞凌办事处。

除非英飞凌科技在英飞凌科技授权代表签署的书面文件中明确批准，否则英飞凌科技的产品不得用于可合理预计产品故障或其使用后果会导致人身伤害的应用。



Part of your life. Part of tomorrow.

