

Features

- 35 ns access time
- Internally organized as 128K × 8
- Hands-off automatic STORE on power-down with only a small capacitor
- STORE to QuantumTrap nonvolatile elements initiated by software, device pin, or autostore on power-down
- RECALL to SRAM initiated by software or power-up
- Infinite read, write, and RECALL cycles
- 1 million STORE cycles to QuantumTrap
- 20-year data retention
- Single 5 V ± 10% operation
- Industrial and Military temperatures
- 32-pin CDIP package

Functional Description

The Cypress STK14CA8C is a fast static RAM, with a nonvolatile element in each memory cell. The memory is organized as 128KB. The embedded nonvolatile elements incorporate QuantumTrap technology, producing the world's most reliable nonvolatile memory. The SRAM provides infinite read and write cycles, while independent nonvolatile data resides in the highly reliable QuantumTrap cell. Data transfers from the SRAM to the nonvolatile elements (the STORE operation) takes place automatically at power-down. On power-up, data is restored to the SRAM (the RECALL operation) from the nonvolatile memory. Both the STORE and RECALL operations are also available under software control.

Logic Block Diagram

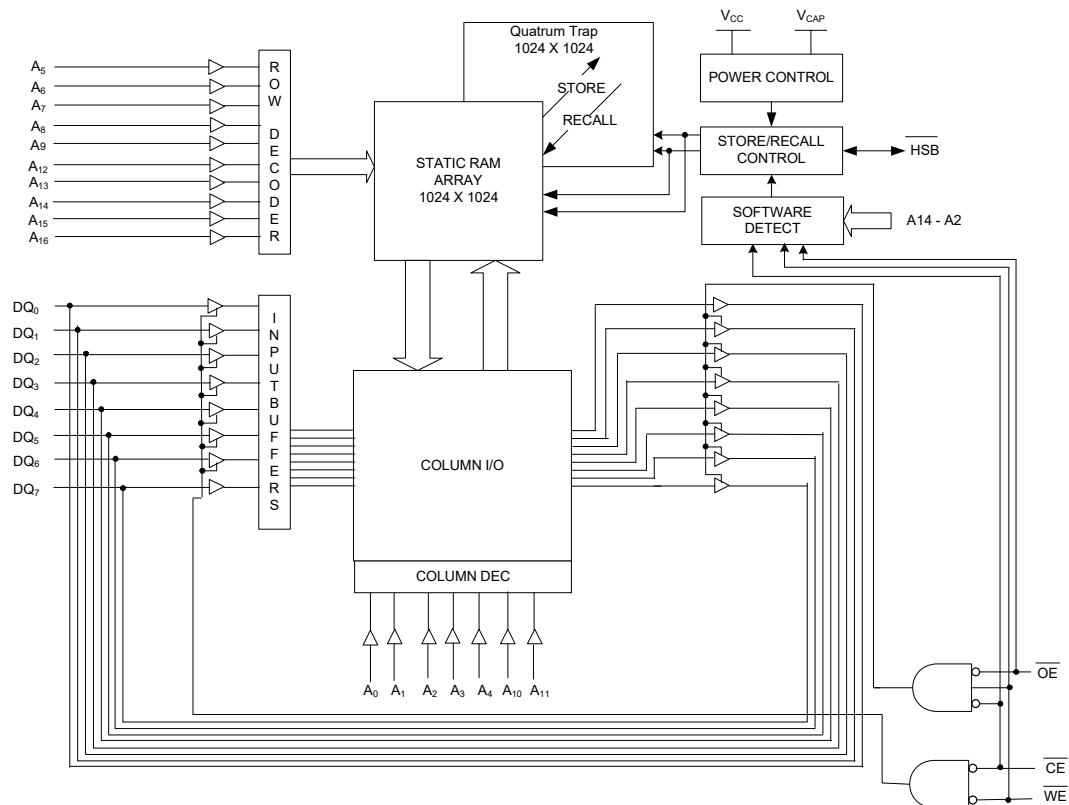

Contents

Pinout	3	AutoStore/Power-up RECALL	13
Pin Definitions	3	Switching Waveforms	13
Device Operation	4	Software Controlled STORE/RECALL Cycle	14
SRAM Read	4	Switching Waveforms	14
SRAM Write	4	Hardware STORE Cycle	15
AutoStore Operation	4	Switching Waveforms	15
Hardware STORE Operation	4	Truth Table For SRAM Operations	16
Hardware RECALL (Power-up)	5	Ordering Information	17
Software STORE	5	Ordering Code Definitions	
Software RECALL	5	for Industrial Temperature	17
Preventing AutoStore	5	Ordering Code Definitions	
Data Protection	5	for Military Temperature	17
Maximum Ratings	7	Package Diagrams	18
Operating Range	7	Acronyms	19
DC Electrical Characteristics	7	Document Conventions	19
Data Retention and Endurance	9	Units of Measure	19
Capacitance	9	Document History Page	20
Thermal Resistance	9	Sales, Solutions, and Legal Information	21
AC Test Loads	9	Worldwide Sales and Design Support	21
AC Test Conditions	9	Products	21
AC Switching Characteristics	10	PSoC® Solutions	21
SRAM Read Cycle	10	Cypress Developer Community	21
SRAM Write Cycle	10	Technical Support	21
Switching Waveforms	11		

Pinout

Figure 1. 32-pin CDIP pinout

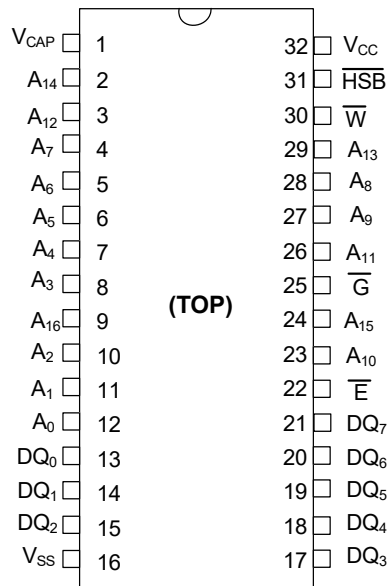

Pin Definitions

Pin Name	Alternate Pin Name	I/O Type	Description
A ₀ -A ₁₆		Input	Address inputs. Used to select one of the 131,072 bytes of the nvSRAM.
DQ ₀ -DQ ₇		Input/Output	Bidirectional data I/O Lines. Used as input or output lines depending on operation.
\overline{W}	\overline{WE}	Input	Write Enable input, Active LOW. When the chip is enabled and \overline{WE} is LOW, data on the I/O pins is written to the specific address location.
\overline{E}	\overline{CE}	Input	Chip Enable input, Active LOW. When LOW, selects the chip. When HIGH, deselects the chip.
\overline{G}	\overline{OE}	Input	Output Enable, Active LOW. The active LOW \overline{OE} input enables the data output buffers during read cycles. I/O pins are tri-stated on deasserting \overline{OE} HIGH.
V _{SS}		Ground	Ground for the device. Must be connected to the ground of the system.
V _{CC}		Power supply	Power supply inputs to the device.
\overline{HSB}		Input/Output	Hardware STORE Busy (\overline{HSB}). When LOW, this output indicates that a Hardware STORE is in progress. When pulled LOW, external to the chip, it initiates a nonvolatile STORE operation. After each Hardware and Software STORE operation \overline{HSB} is driven HIGH for a short time (t_{HHHD}) with standard output high current and then a weak internal pull-up resistor keeps this pin HIGH (external pull-up resistor connection is optional).
V _{CAP}		Power supply	AutoStore capacitor. Supplies power to the nvSRAM during power loss to store data from SRAM to nonvolatile elements.

Device Operation

The STK14CA8C nvSRAM is made up of two functional components paired in the same physical cell. They are an SRAM memory cell and a nonvolatile QuantumTrap cell. The SRAM memory cell operates as a standard fast static RAM. Data in the SRAM is transferred to the nonvolatile cell (the STORE operation), or from the nonvolatile cell to the SRAM (the RECALL operation). Using this unique architecture, all cells are stored and recalled in parallel. During the STORE and RECALL operations, SRAM read and write operations are inhibited. The STK14CA8C supports infinite reads and writes similar to a typical SRAM. In addition, it provides infinite RECALL operations from the nonvolatile cells and up to 1 million STORE operations. Refer to the [Truth Table For SRAM Operations on page 16](#) for a complete description of read and write modes.

SRAM Read

The STK14CA8C performs a read cycle when \overline{CE} and \overline{OE} are LOW and \overline{WE} and HSB are HIGH. The address specified on pins A_{0-16} determines which of the 131,072 data bytes each are accessed. When the read is initiated by an address transition, the outputs are valid after a delay of t_{AA} (read cycle 1). If the read is initiated by \overline{CE} or \overline{OE} , the outputs are valid at t_{ACE} or at t_{DOE} , whichever is later (read cycle 2). The data output repeatedly responds to address changes within the t_{AA} access time without the need for transitions on any control input pins. This remains valid until another address change or until \overline{CE} or \overline{OE} is brought HIGH, or \overline{WE} or HSB is brought LOW.

SRAM Write

A write cycle is performed when \overline{CE} and \overline{WE} are LOW and HSB is HIGH. The address inputs must be stable before entering the write cycle and must remain stable until \overline{CE} or \overline{WE} goes HIGH at the end of the cycle. The data on the common I/O pins DQ_{0-7} are written into the memory if the data is valid t_{SD} before the end of a \overline{WE} -controlled write or before the end of a \overline{CE} -controlled write. Keep \overline{OE} HIGH during the entire write cycle to avoid data bus contention on common I/O lines. If \overline{OE} is left LOW, internal circuitry turns off the output buffers t_{HZWE} after \overline{WE} goes LOW.

AutoStore Operation

The STK14CA8C stores data to the nvSRAM using one of the following three storage operations: Hardware STORE activated by HSB; Software STORE activated by an address sequence; AutoStore on device power-down. The AutoStore operation is a unique feature of QuantumTrap technology and is enabled by default on the STK14CA8C.

During a normal operation, the device draws current from V_{CC} to charge a capacitor connected to the V_{CAP} pin. This stored charge is used by the chip to perform a single STORE operation. If the voltage on the V_{CC} pin drops below V_{SWITCH} , the part automatically disconnects the V_{CAP} pin from V_{CC} . A STORE operation is initiated with power provided by the V_{CAP} capacitor.

Note If the capacitor is not connected to V_{CAP} pin, AutoStore must be disabled using the soft sequence specified in [Preventing AutoStore on page 5](#). In case AutoStore is enabled without a capacitor on V_{CAP} pin, the device attempts an AutoStore operation without sufficient charge to complete the Store. This corrupts the data stored in nvSRAM.

Figure 2 shows the proper connection of the storage capacitor (V_{CAP}) for automatic STORE operation. Refer to [DC Electrical Characteristics on page 7](#) for the size of V_{CAP} . The voltage on the V_{CAP} pin is driven to V_{CC} by a regulator on the chip. Place a pull-up on \overline{WE} to hold it inactive during power-up. This pull-up is only effective if the \overline{WE} signal is tristate during power-up. Many MPUs tristate their controls on power-up. This must be verified when using the pull-up. When the nvSRAM comes out of power-on-RECALL, the MPU must be active or the \overline{WE} held inactive until the MPU comes out of reset.

To reduce unnecessary nonvolatile stores, AutoStore and Hardware STORE operations are ignored unless at least one write operation has taken place since the most recent STORE or RECALL cycle. Software initiated STORE cycles are performed regardless of whether a write operation has taken place. The HSB signal is monitored by the system to detect if an AutoStore cycle is in progress.

Figure 2. AutoStore Mode

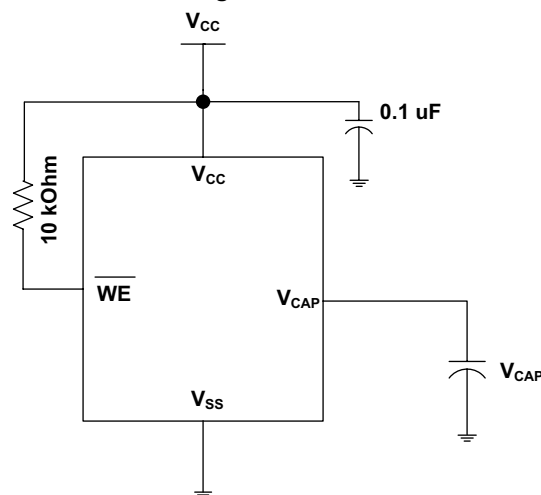

Hardware STORE Operation

The STK14CA8C provides the \overline{HSB} pin to control and acknowledge the STORE operations. Use the \overline{HSB} pin to request a Hardware STORE cycle. When the \overline{HSB} pin is driven LOW, the STK14CA8C conditionally initiates a STORE operation after t_{DELAY} . An actual STORE cycle only begins if a write to the SRAM has taken place since the last STORE or RECALL cycle. The \overline{HSB} pin also acts as an open drain driver (internal 100 k Ω weak pull-up resistor) that is internally driven LOW to indicate a busy condition when the STORE (initiated by any means) is in progress.

Note After each Hardware and Software STORE operation \overline{HSB} is driven HIGH for a short time (t_{HHHD}) with standard output high current and then remains HIGH by internal 100 k Ω pull-up resistor.

SRAM write operations that are in progress when \overline{HSB} is driven LOW by any means are given time (t_{DELAY}) to complete before the STORE operation is initiated. However, any SRAM write cycles requested after \overline{HSB} goes LOW are inhibited until \overline{HSB} returns HIGH. In case the write latch is not set, \overline{HSB} is not driven LOW by the STK14CA8C. But any SRAM read and write cycles are inhibited until \overline{HSB} is returned HIGH by MPU or other external source.

During any STORE operation, regardless of how it is initiated, the STK14CA8C continues to drive the HSB pin LOW, releasing it only when the STORE is complete. Upon completion of the STORE operation, the nvSRAM memory access is inhibited for t_{LZHSB} time after HSB pin returns HIGH. Leave the HSB unconnected if it is not used.

Hardware RECALL (Power-up)

During power-up or after any low power condition ($V_{CC} < V_{SWITCH}$), an internal RECALL request is latched. When V_{CC} again exceeds the sense voltage of V_{SWITCH} , a RECALL cycle is automatically initiated and takes $t_{HRECALL}$ to complete. During this time, HSB is driven low by the HSB driver.

Software STORE

Data is transferred from SRAM to the nonvolatile memory by a software address sequence. The STK14CA8C Software STORE cycle is initiated by executing sequential \overline{CE} or \overline{OE} controlled read cycles from six specific address locations in exact order. During the STORE cycle an erase of the previous nonvolatile data is first performed, followed by a program of the nonvolatile elements. After a STORE cycle is initiated, further input and output are disabled until the cycle is completed.

Because a sequence of READs from specific addresses is used for STORE initiation, it is important that no other read or write accesses intervene in the sequence, or the sequence is aborted and no STORE or RECALL takes place.

To initiate the Software STORE cycle, the following read sequence must be performed:

1. Read address 0x4E38 Valid READ
2. Read address 0xB1C7 Valid READ
3. Read address 0x83E0 Valid READ
4. Read address 0x7C1F Valid READ
5. Read address 0x703F Valid READ
6. Read address 0x0FC0 Initiate STORE cycle

The software sequence may be clocked with \overline{CE} controlled reads or \overline{OE} controlled reads, with \overline{WE} kept HIGH for all the six READ sequences. After the sixth address in the sequence is entered, the STORE cycle commences and the chip is disabled. HSB is driven LOW. After the t_{STORE} cycle time is fulfilled, the SRAM is activated again for the read and write operation.

Software RECALL

Data is transferred from nonvolatile memory to the SRAM by a software address sequence. A Software RECALL cycle is initiated with a sequence of read operations in a manner similar to the Software STORE initiation. To initiate the RECALL cycle, the following sequence of \overline{CE} or \overline{OE} controlled read operations must be performed:

1. Read address 0x4E38 Valid READ
2. Read address 0xB1C7 Valid READ

3. Read address 0x83E0 Valid READ
4. Read address 0x7C1F Valid READ
5. Read address 0x703F Valid READ
6. Read address 0x0C63 Initiate RECALL cycle

Internally, RECALL is a two step procedure. First, the SRAM data is cleared. Next, the nonvolatile information is transferred into the SRAM cells. After the t_{RECALL} cycle time, the SRAM is again ready for read and write operations. The RECALL operation does not alter the data in the nonvolatile elements.

Preventing AutoStore

The AutoStore function is disabled by initiating an AutoStore disable sequence. A sequence of read operations is performed in a manner similar to the Software STORE initiation. To initiate the AutoStore disable sequence, the following sequence of \overline{CE} or \overline{OE} controlled read operations must be performed:

1. Read address 0x4E38 Valid READ
2. Read address 0xB1C7 Valid READ
3. Read address 0x83E0 Valid READ
4. Read address 0x7C1F Valid READ
5. Read address 0x703F Valid READ
6. Read address 0x0B45 AutoStore Disable

The AutoStore is reenabled by initiating an AutoStore enable sequence. A sequence of read operations is performed in a manner similar to the Software RECALL initiation. To initiate the AutoStore enable sequence, the following sequence of \overline{CE} or \overline{OE} controlled read operations must be performed:

1. Read address 0x4E38 Valid READ
2. Read address 0xB1C7 Valid READ
3. Read address 0x83E0 Valid READ
4. Read address 0x7C1F Valid READ
5. Read address 0x703F Valid READ
6. Read address 0x0B46 AutoStore Enable

If the AutoStore function is disabled or reenabled, a manual STORE operation (Hardware or Software) must be issued to save the AutoStore state through subsequent power-down cycles. The part comes from the factory with AutoStore enabled and 0x00 written in all cells.

Data Protection

The STK14CA8C protects data from corruption during low voltage conditions by inhibiting all externally initiated STORE and write operations. The low voltage condition is detected when V_{CC} is less than V_{SWITCH} . If the STK14CA8C is in a write mode (both \overline{CE} and \overline{WE} are LOW) at power-up, after a RECALL or STORE, the write is inhibited until the SRAM is enabled after t_{LZHSB} (HSB to output active). This protects against inadvertent writes during power-up or brown out conditions.

Table 1. Mode Selection

$\overline{\text{CE}}$	$\overline{\text{WE}}$	$\overline{\text{OE}}$	$\text{A}_{16}\text{-A}_0^{[1]}$	Mode	I/O	Power
H	X	X	X	Not selected	Output high Z	Standby
L	H	L	X	Read SRAM	Output data	Active
L	L	X	X	Write SRAM	Input data	Active
L	H	L	0x4E38 0xB1C7 0x83E0 0x7C1F 0x703F 0x8B45	Read SRAM Read SRAM Read SRAM Read SRAM Read SRAM AutoStore disable	Output data Output data data Output data Output data Output data data Output data	Active ^[2]
L	H	L	0x4E38 0xB1C7 0x83E0 0x7C1F 0x703F 0x4B46	Read SRAM Read SRAM Read SRAM Read SRAM Read SRAM AutoStore enable	Output data Output data data Output data Output data Output data data Output data	Active ^[2]
L	H	L	0x4E38 0xB1C7 0x83E0 0x7C1F 0x703F 0x8FC0	Read SRAM Read SRAM Read SRAM Read SRAM Read SRAM Nonvolatile STORE	Output data Output data data Output data Output data Output data data Output high Z	Active $I_{CC2}^{[2]}$
L	H	L	0x4E38 0xB1C7 0x83E0 0x7C1F 0x703F 0x4C63	Read SRAM Read SRAM Read SRAM Read SRAM Read SRAM Nonvolatile RECALL	Output data Output data data Output data Output data Output data data Output high Z	Active ^[2]

Notes

1. While there are 17 address lines on the STK14CA8C, only the lower 14 are used to control software modes.
2. The six consecutive address locations must be in the order listed. WE must be HIGH during all six cycles to enable a nonvolatile cycle.

Maximum Ratings

Exceeding maximum ratings may shorten the useful life of the device. These user guidelines are not tested.

Storage temperature -65 °C to +150 °C

Maximum accumulated storage time:

At 150 °C ambient temperature 1000 h

At 85 °C ambient temperature 20 Years

Maximum junction temperature 150 °C

Supply voltage on V_{CC} relative to V_{SS} -0.5 V to 7.0 V

Voltage applied to outputs

in high Z state -0.5 V to $V_{CC} + 0.5$ V

Input voltage -0.5 V to $V_{CC} + 0.5$ V

Transient voltage (< 20 ns)

on any pin to ground potential -2.0 V to $V_{CC} + 2.0$ V

Package power dissipation capability

($T_A = 25$ °C) 1.0 W

Surface mount Pb soldering temperature

(3 seconds) +260 °C

DC output current

(1 output at a time, 1 s duration) 15 mA

Static discharge voltage

(per MIL-STD-883, Method 3015) > 2001 V

Latch-up current > 140 mA

Operating Range

Range	Ambient Temperature	V_{CC}
Industrial	-40 °C to +85 °C	4.5 V to 5.5 V
Military	-55 °C to +125 °C	4.5 V to 5.5 V

DC Electrical Characteristics

Over the [Operating Range](#)

Parameter	Description	Test Conditions	Min	Typ ^[3]	Max	Unit	
V_{CC}	Power supply		4.5	5.0	5.5	V	
I_{CC1}	Average V_{CC} current	$t_{RC} = 35$ ns Values obtained without output loads ($I_{OUT} = 0$ mA)	Industrial Military	-	-	70 85	mA
I_{CC2}	Average V_{CC} current during STORE	All inputs don't care, $V_{CC} = \text{Max}$ Average current for duration t_{STORE}	Industrial Military	-	-	10 15	mA
I_{CC3}	Average V_{CC} current at $t_{RC} = 200$ ns, $V_{CC(Typ)}$, 25 °C	All inputs cycling at CMOS levels. Values obtained without output loads ($I_{OUT} = 0$ mA).		-	35	-	mA
I_{CC4}	Average V_{CAP} current during AutoStore cycle	All inputs don't care. Average current for duration t_{STORE}	Industrial Military	-	-	5 10	mA
I_{SB}	V_{CC} standby current	$\overline{CE} \geq (V_{CC} - 0.2$ V). $V_{IN} \leq 0.2$ V or $\geq (V_{CC} - 0.2$ V). Standby current level after nonvolatile cycle is complete. Inputs are static. $f = 0$ MHz.	Industrial Military	-	-	5 10	mA
$I_{IX}^{[4]}$	Input leakage current (except HSB)	$V_{CC} = \text{Max}$, $V_{SS} \leq V_{IN} \leq V_{CC}$	Industrial	-1	-	+1	μ A
	Input leakage current (for HSB)		Military	-5	-	+5	μ A
			Industrial	-100	-	+1	μ A
			Military	-100	-	+5	μ A
I_{OZ}	Off-state output leakage current	$V_{CC} = \text{Max}$, $V_{SS} \leq V_{OUT} \leq V_{CC}$, \overline{CE} or $OE \geq V_{IH}$ or $WE \leq V_{IL}$	Industrial Military	-1	-	+1 +5	μ A

Notes

3. Typical values are at 25 °C, $V_{CC} = V_{CC(Typ)}$. Not 100% tested.

4. The HSB pin has $I_{OUT} = -2$ μ A for V_{OH} of 2.4 V when both active high and low drivers are disabled. When they are enabled standard V_{OH} and V_{OL} are valid. This parameter is characterized but not tested.

DC Electrical Characteristics (continued)

 Over the [Operating Range](#)

Parameter	Description	Test Conditions	Min	Typ ^[3]	Max	Unit	
V _{IH}	Input HIGH voltage		Industrial	2.0	–	V _{CC} + 0.5	V
			Military	2.2	–	V _{CC} + 0.5	V
V _{IL}	Input LOW voltage		V _{SS} – 0.5	–	0.8	V	
V _{OH}	Output HIGH voltage	I _{OUT} = –2 mA	2.4	–	–	V	
V _{OL}	Output LOW voltage	I _{OUT} = 4 mA	–	–	0.4	V	
V _{CAP} ^[5]	Storage capacitor	Between V _{CAP} pin and V _{SS}	61	68	180	μF	
V _{V_{CAP}} ^[6, 7]	Maximum voltage driven on V _{CAP} pin by the device	V _{CC} = Max	–	–	V _{CC} – 0.5	V	

Notes

5. Min V_{CAP} value guarantees that there is a sufficient charge available to complete a successful AutoStore operation. Max V_{CAP} value guarantees that the capacitor on V_{CAP} is charged to a minimum voltage during a Power-Up RECALL cycle so that an immediate power-down cycle can complete a successful AutoStore. Therefore it is always recommended to use a capacitor within the specified min and max limits. Refer application note [AN43593](#) for more details on V_{CAP} options.
6. Maximum voltage on V_{CAP} pin (V_{V_{CAP}}) is provided for guidance when choosing the V_{CAP} capacitor. The voltage rating of the V_{CAP} capacitor across the operating temperature range should be higher than the V_{V_{CAP}} voltage.
7. These parameters are guaranteed by design and are not tested.

Data Retention and Endurance

Over the [Operating Range](#)

Parameter	Description		Min	Unit
DATA _R	Data retention	Industrial	20	Years
		Military	1	
NV _C	Nonvolatile STORE operations	Industrial	1,000	K
		Military	100	

Capacitance

Parameter ^[8]	Description	Test Conditions	Max	Unit
C _{IN}	Input capacitance (except HSB)	T _A = 25 °C, f = 1 MHz, V _{CC} = V _{CC(Typ)}	7	pF
	Input capacitance (for HSB)		8	pF
C _{OUT}	Output capacitance (except HSB)		7	pF
	Output capacitance (for HSB)		8	pF

Thermal Resistance

Parameter ^[8]	Description	Test Conditions	32-pin CDIP	Unit
Θ _{JA}	Thermal resistance (junction to ambient)	Test conditions follow standard test methods and procedures for measuring thermal impedance, in accordance with EIA/JESD51.	22.3	°C/W
Θ _{JC}	Thermal resistance (junction to case)		11	°C/W

AC Test Loads

Figure 3. AC Test Loads

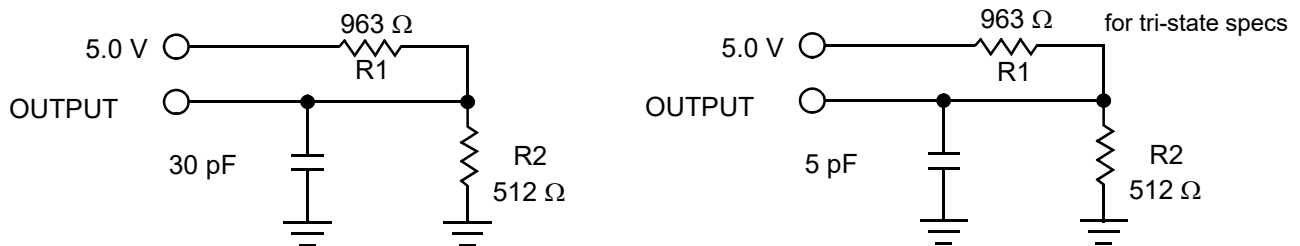

AC Test Conditions

Input Pulse Levels 0 V to 3 V
 Input Rise and Fall Times (10% to 90%) ≤ 3 ns
 Input and Output Timing Reference Levels 1.5 V

Note

8. These parameters are guaranteed by design and are not tested.

AC Switching Characteristics

Over the [Operating Range](#)

Parameters ^[9]		Description	35 ns		Unit
Cypress Parameter	Alt Parameter		Min	Max	
SRAM Read Cycle					
t _{ACE}	t _{ACS}	Chip enable access time	–	35	ns
t _{RC} ^[10]	t _{RC}	Read cycle time	35	–	ns
t _{AA} ^[11]	t _{AA}	Address access time	–	35	ns
t _{DOE}	t _{OE}	Output enable to data valid	–	15	ns
t _{OHA} ^[11]	t _{OH}	Output hold after address change	3	–	ns
t _{LZCE} ^[12, 13]	t _{LZ}	Chip enable to output active	3	–	ns
t _{HZCE} ^[12, 13]	t _{HZ}	Chip disable to output inactive	–	13	ns
t _{LZOE} ^[12, 13]	t _{OLZ}	Output enable to output active	0	–	ns
t _{HZOE} ^[12, 13]	t _{OHz}	Output disable to output inactive	–	13	ns
t _{PU} ^[12]	t _{PA}	Chip enable to power active	0	–	ns
t _{PD} ^[12]	t _{PS}	Chip disable to power standby	–	35	ns
SRAM Write Cycle					
t _{WC}	t _{WC}	Write cycle time	35	–	ns
t _{PWE}	t _{WP}	Write pulse width	25	–	ns
t _{SCE}	t _{CW}	Chip enable to end of write	25	–	ns
t _{SD}	t _{DW}	Data setup to end of write	12	–	ns
t _{HD}	t _{DH}	Data hold after end of write	0	–	ns
t _{AW}	t _{AW}	Address setup to end of write	25	–	ns
t _{SA}	t _{AS}	Address setup to start of write	0	–	ns
t _{HA}	t _{WR}	Address hold after end of write	0	–	ns
t _{HZWE} ^[12, 13, 14]	t _{WZ}	Write enable to output disable	–	13	ns
t _{LZWE} ^[12, 13]	t _{OW}	Output active after end of write	3	–	ns

Notes

9. Test conditions assume signal transition time of 3 ns or less, timing reference levels of $V_{CC}/2$, input pulse levels of 0 to V_{CC} (typ), and output loading of the specified I_{OL}/I_{OH} and load capacitance shown in [Figure 3 on page 9](#).
10. WE must be HIGH during SRAM read cycles.
11. Device is continuously selected with CE and OE LOW.
12. These parameters are guaranteed by design and are not tested.
13. Measured ± 200 mV from steady state output voltage.
14. If WE is low when CE goes low, the outputs remain in the high impedance state.

Switching Waveforms

Figure 4. SRAM Read Cycle No. 1 (Address Controlled) [15, 16, 17]

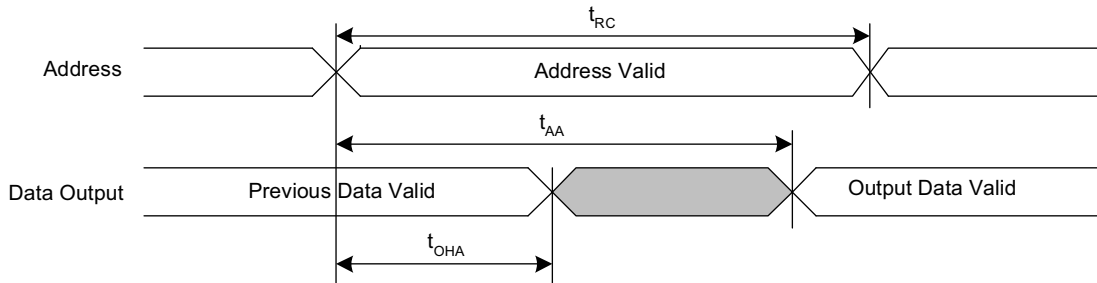
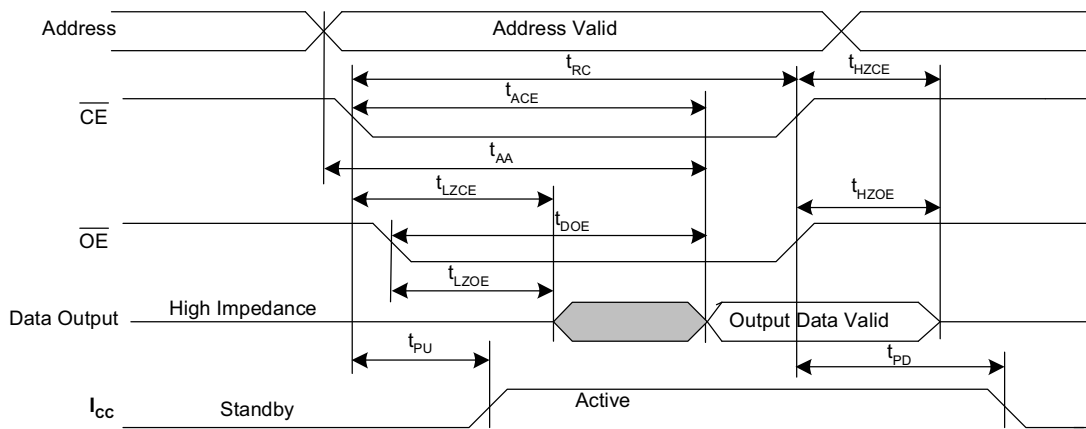

Figure 5. SRAM Read Cycle No. 2 (\overline{CE} and \overline{OE} Controlled) [15, 17]



Notes

- 15. \overline{WE} must be HIGH during SRAM read cycles.
- 16. Device is continuously selected with \overline{CE} and \overline{OE} LOW.
- 17. HSB must remain HIGH during READ and WRITE cycles.

Switching Waveforms (continued)

Figure 6. SRAM Write Cycle No. 1 (\overline{WE} Controlled) [18, 19, 20]

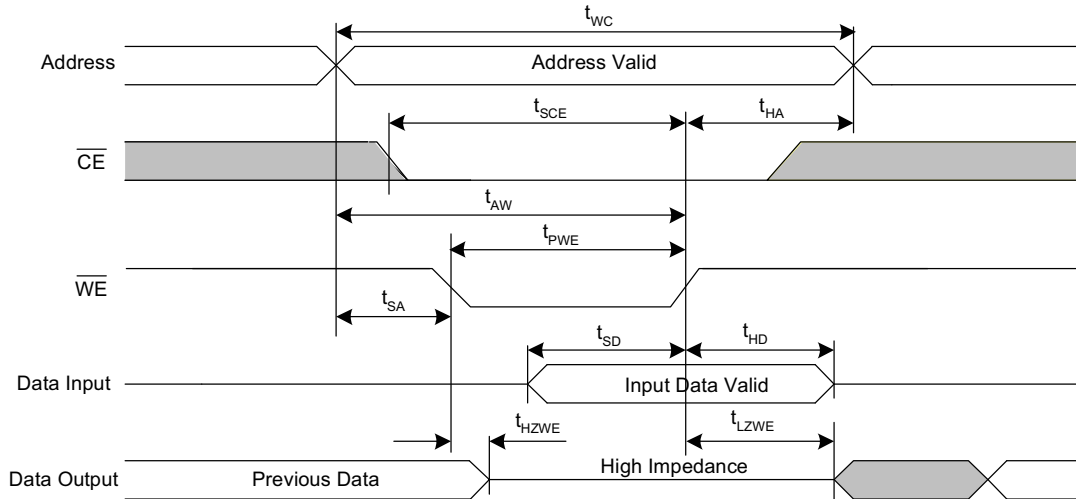
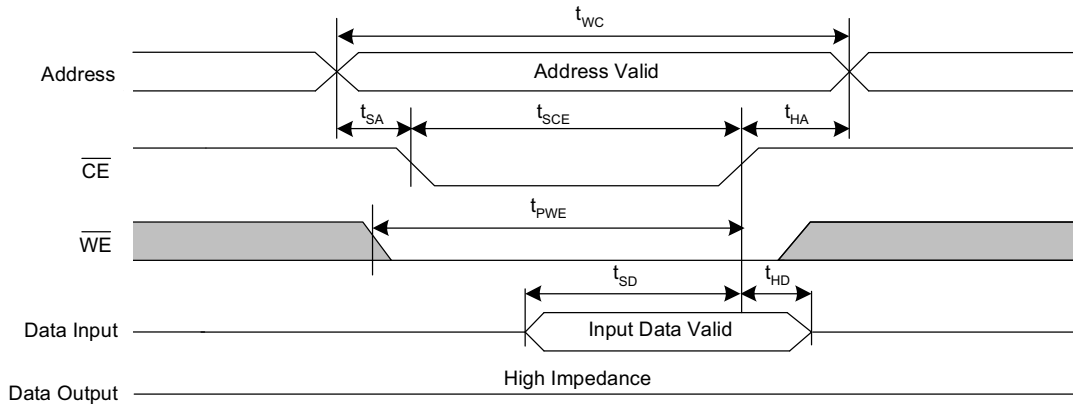

Figure 7. SRAM Write Cycle No. 2 (\overline{CE} Controlled) [18, 19, 20]



Notes

- 18. \overline{HSB} must remain HIGH during READ and WRITE cycles.
- 19. If \overline{WE} is low when \overline{CE} goes low, the outputs remain in the high impedance state.
- 20. \overline{CE} or \overline{WE} must be $\geq V_{IH}$ during address transitions.

AutoStore/Power-up RECALL

Over the Operating Range

Parameter	Description	STK14CA8C		Unit
		Min	Max	
$t_{HRECALL}^{[21]}$	Power-up RECALL duration	–	20	ms
$t_{STORE}^{[22]}$	STORE cycle duration	–	8	ms
$t_{DELAY}^{[23]}$	Time allowed to complete SRAM write cycle	–	35	ns
V_{SWITCH}	Low voltage trigger level	–	4.4	V
$t_{VCCRRISE}^{[24]}$	V_{CC} rise time	150	–	μ s
$V_{HDIS}^{[24]}$	HSB output disable voltage	–	1.9	V
$t_{LZHSB}^{[24]}$	HSB to output active time	–	5	μ s
$t_{HHHD}^{[24]}$	HSB high active time	–	500	ns

Switching Waveforms

Figure 8. AutoStore or Power-up RECALL ^[25]

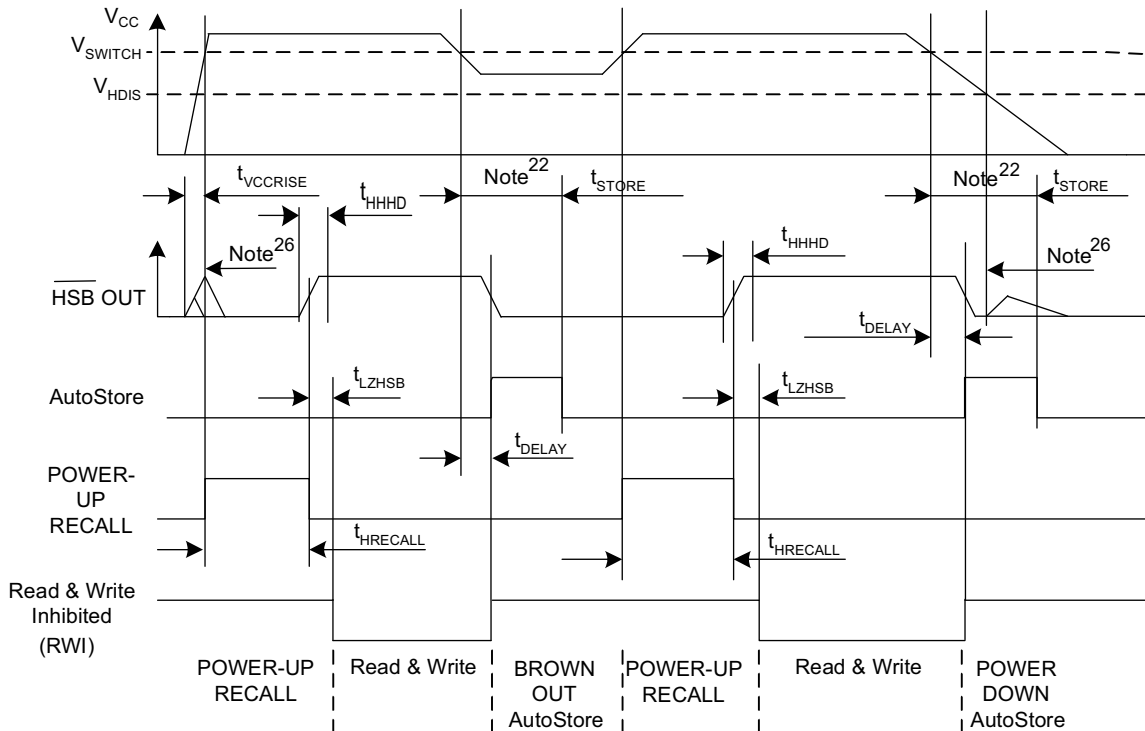

Notes

21. $t_{HRECALL}$ starts from the time V_{CC} rises above V_{SWITCH} .
22. If an SRAM write has not taken place since the last nonvolatile cycle, no AutoStore or Hardware STORE takes place.
23. On a Hardware STORE and AutoStore initiation, SRAM write operation continues to be enabled for time t_{DELAY} .
24. These parameters are guaranteed by design and are not tested.
25. Read and Write cycles are ignored during STORE, RECALL, and while V_{CC} is less than V_{SWITCH} .
26. During power-up and power-down, HSB glitches when HSB pin is pulled up through an external resistor.

Software Controlled STORE/RECALL Cycle

Over the [Operating Range](#)

Parameter [27, 28]	Description	35 ns		Unit
		Min	Max	
t_{RC}	STORE/RECALL initiation cycle time	35	–	ns
t_{SA}	Address setup time	0	–	ns
t_{CW}	Clock pulse width	25	–	ns
t_{HA}	Address hold time	0	–	ns
t_{RECALL}	RECALL duration	–	200	μ s

Switching Waveforms

Figure 9. \overline{CE} and \overline{OE} Controlled Software STORE/RECALL Cycle [28]

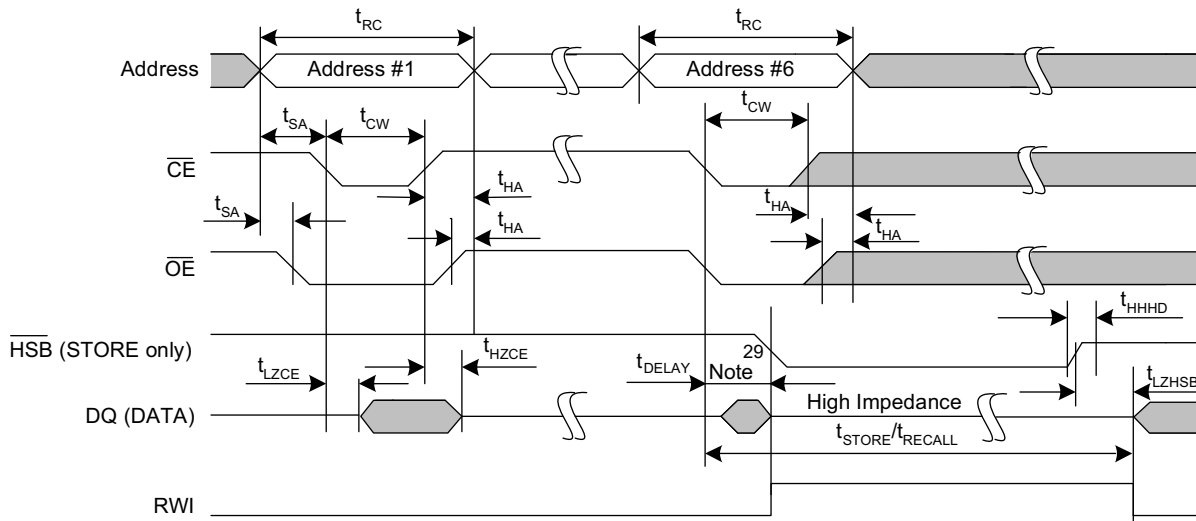
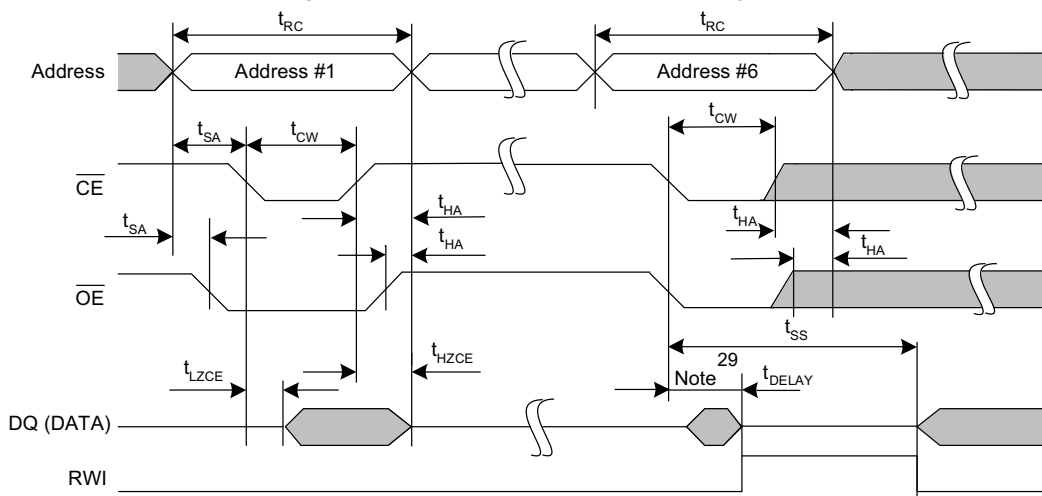

Figure 10. AutoStore Enable / Disable Cycle [28]



Notes

27. The software sequence is clocked with \overline{CE} controlled or \overline{OE} controlled reads.

28. The six consecutive addresses must be read in the order listed in [Table 1 on page 6](#). \overline{WE} must be HIGH during all six consecutive cycles.

29. DQ output data at the sixth read may be invalid since the output is disabled at t_{DELAY} time.

Hardware STORE Cycle

Over the [Operating Range](#)

Parameter	Description	STK14CA8C		Unit
		Min	Max	
t_{DHSB}	HSB to output active time when write latch not set	–	35	ns
t_{PHSB}	Hardware STORE pulse width	15	–	ns
$t_{SS}^{[30, 31]}$	Soft sequence processing time	–	100	μ s

Switching Waveforms

Figure 11. Hardware STORE Cycle ^[32]

Write Latch set

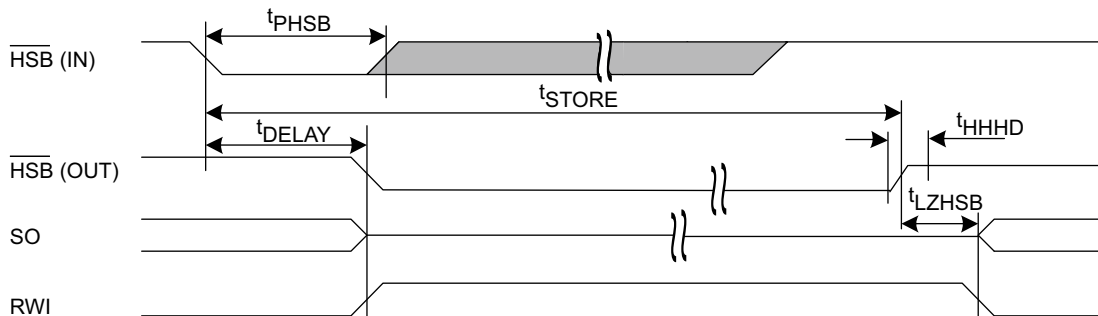

Write Latch not set

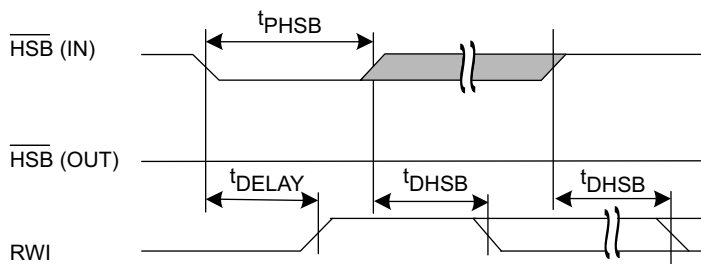

HSB pin is driven high to V_{CCQ} only by Internal 100 K Ω resistor, HSB driver is disabled
SRAM is disabled as long as HSB (IN) is driven LOW.

Figure 12. Soft Sequence Processing ^[30, 31]

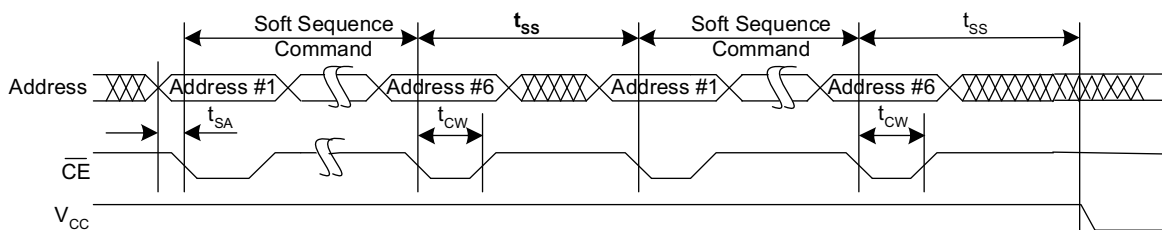

Notes

30. This is the amount of time it takes to take action on a soft sequence command. Vcc power must remain HIGH to effectively register command.

31. Commands such as STORE and RECALL lock out I/O until operation is complete which further increases this time. See the specific command.

32. If an SRAM write has not taken place since the last nonvolatile cycle, no AutoStore or Hardware STORE takes place.

Truth Table For SRAM Operations

$\overline{\text{HSB}}$ must remain HIGH for SRAM operations.

$\overline{\text{CE}}$	$\overline{\text{WE}}$	$\overline{\text{OE}}$	Inputs/Outputs	Mode	Power
H	X	X	High Z	Deselect/power-down	Standby
L	H	L	Data out (DQ ₀ –DQ ₇)	Read	Active
L	H	H	High Z	Output disabled	Active
L	L	X	Data in (DQ ₀ –DQ ₇)	Write	Active

Ordering Information

Speed (ns)	Ordering Code	Package Diagram	Package Type	Operating Range
35	STK14CA8C-5C35M	002-23724	32-pin CDIP	Military

All the mentioned parts are Pb-free.

Ordering Code Definitions for Industrial Temperature

STK14C88C- C 35 I TR

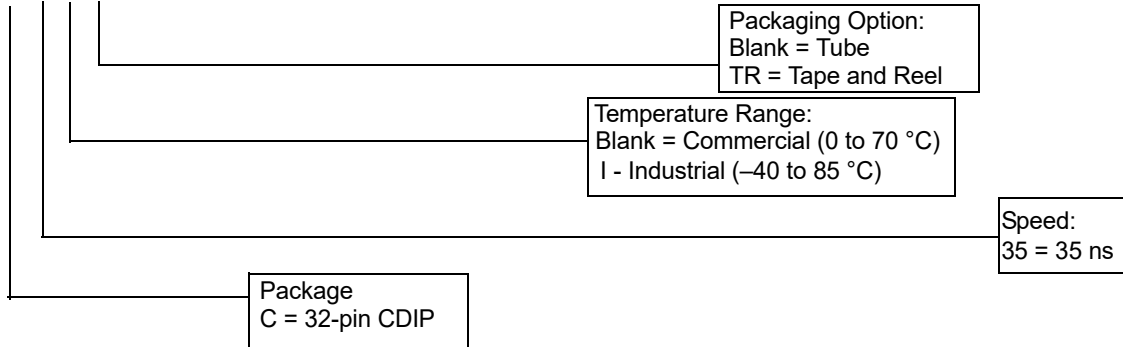

Ordering Code Definitions for Military Temperature

STK14C88C - 5 C 35 M TR

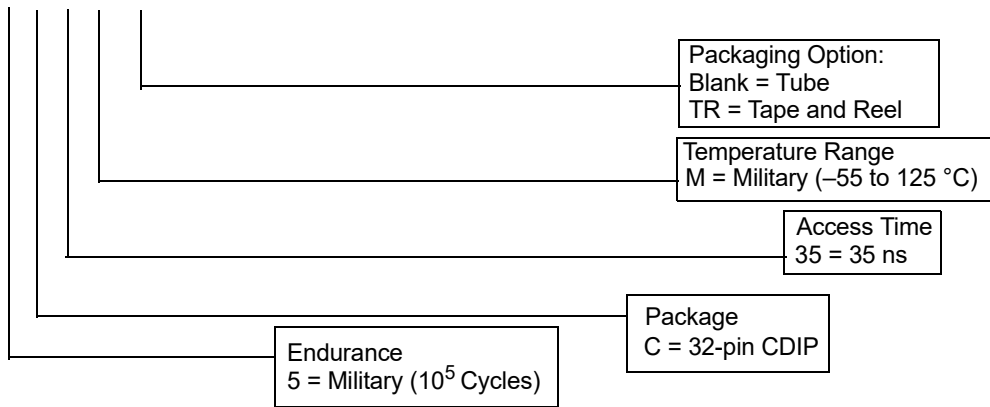

5962-18212 01 Q X C TR

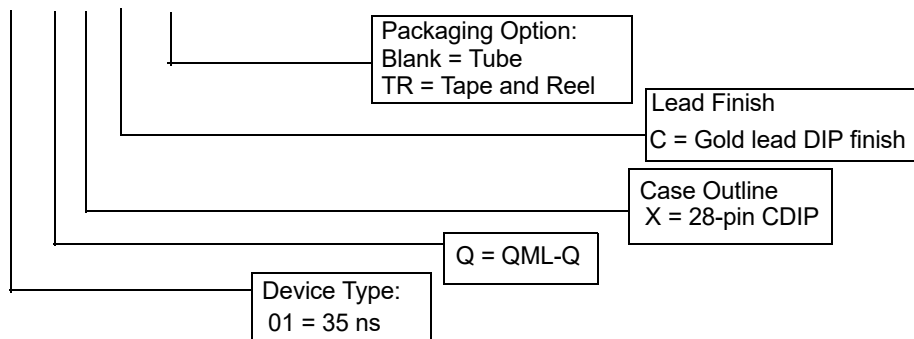

Package Diagram

Figure 13. 32-pin Side Braze DIP (40.64 × 7.49 × 3.96 mm) Package Outline, 002-23724

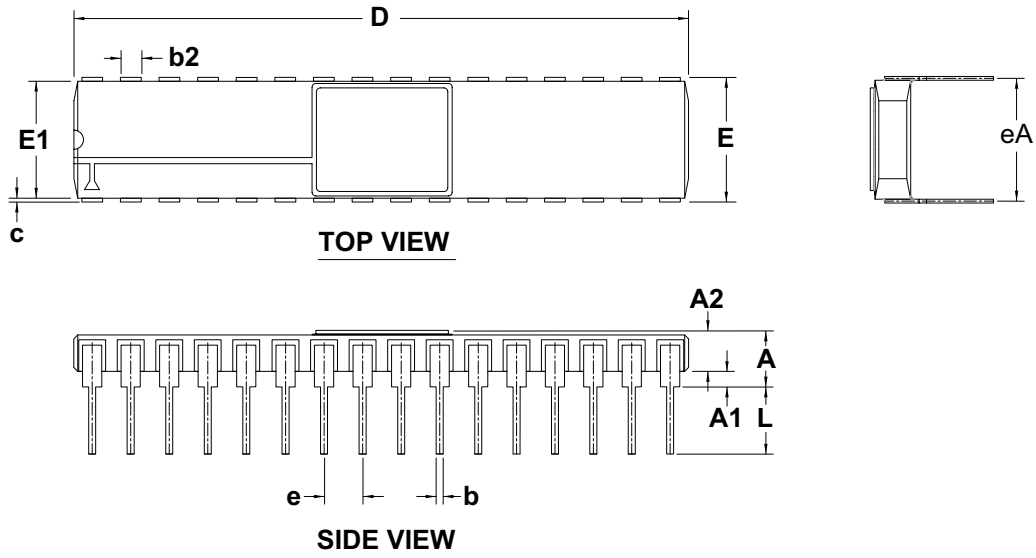

SYMBOL	DIMENSIONS		
	MIN	NOM	MAX
A	-	-	3.96
A1	1.02	1.27	1.52
A2	2.18	-	2.44
b	0.38	0.48	0.58
b2	1.14	-	1.65
c	0.23	0.25	0.31
D	40.26	40.64	41.91
E	7.36	7.87	8.13
E1	7.24	7.49	7.75
e	2.54 BSC		
eA	7.62 REF		
L	3.18	-	4.31

NOTES:
1. ALL DIMENSIONS ARE IN MILLIMETERS.

002-23724 *B

Acronyms

Acronym	Description
CE	chip enable
CMOS	complementary metal oxide semiconductor
EIA	electronic industries alliance
HSB	hardware store busy
I/O	input/output
JEDEC	joint electron devices engineering council
nvSRAM	non-volatile static random access memory
OE	output enable
RoHS	restriction of hazardous substances
RWI	read and write inhibited
SRAM	static random access memory
WE	write enable

Document Conventions

Units of Measure

Symbol	Unit of Measure
°C	degree Celsius
kΩ	kilohm
MHz	megahertz
μA	microampere
μF	microfarad
μs	microsecond
mA	milliampere
ms	millisecond
mV	millivolt
ns	nanosecond
Ω	ohm
%	percent
pF	picofarad
ps	picosecond
V	volt
W	watt

Document History Page

Document Title: STK14CA8C, 1-Mbit (128K × 8) nvSRAM Document Number: 002-23970				
Revision	ECN	Orig. of Change	Submission Date	Description of Change
**	6193782	GVCH	07/11/2018	New data sheet.
*A	6478873	GVCH	03/26/2019	Datasheet status changed from Preliminary to Final Maximum Ratings : Updated latch-up current to 140 mA for Industrial and Military Temperature Thermal Resistance : Added Θ_{JA} and Θ_{JC} values Ordering Information : Removed STK14CA8C-C35I and 5962-1821201QXC parts

Sales, Solutions, and Legal Information

Worldwide Sales and Design Support

Cypress maintains a worldwide network of offices, solution centers, manufacturer's representatives, and distributors. To find the office closest to you, visit us at [Cypress Locations](#).

Products

Arm [®] Cortex [®] Microcontrollers	cypress.com/arm
Automotive	cypress.com/automotive
Clocks & Buffers	cypress.com/clocks
Interface	cypress.com/interface
Internet of Things	cypress.com/iot
Memory	cypress.com/memory
Microcontrollers	cypress.com/mcu
PSoC	cypress.com/psoc
Power Management ICs	cypress.com/pmic
Touch Sensing	cypress.com/touch
USB Controllers	cypress.com/usb
Wireless Connectivity	cypress.com/wireless

PSoC[®] Solutions

[PSoC 1](#) | [PSoC 3](#) | [PSoC 4](#) | [PSoC 5LP](#) | [PSoC 6 MCU](#)

Cypress Developer Community

[Community](#) | [Projects](#) | [Video](#) | [Blogs](#) | [Training](#) | [Components](#)

Technical Support

cypress.com/support

© Cypress Semiconductor Corporation, 2018-2019. This document is the property of Cypress Semiconductor Corporation and its subsidiaries, including Spansion LLC ("Cypress"). This document, including any software or firmware included or referenced in this document ("Software"), is owned by Cypress under the intellectual property laws and treaties of the United States and other countries worldwide. Cypress reserves all rights under such laws and treaties and does not, except as specifically stated in this paragraph, grant any license under its patents, copyrights, trademarks, or other intellectual property rights. If the Software is not accompanied by a license agreement and you do not otherwise have a written agreement with Cypress governing the use of the Software, then Cypress hereby grants you a personal, non-exclusive, nontransferable license (without the right to sublicense) (1) under its copyright rights in the Software (a) for Software provided in source code form, to modify and reproduce the Software solely for use with Cypress hardware products, only internally within your organization, and (b) to distribute the Software in binary code form externally to end users (either directly or indirectly through resellers and distributors), solely for use on Cypress hardware product units, and (2) under those claims of Cypress's patents that are infringed by the Software (as provided by Cypress, unmodified) to make, use, distribute, and import the Software solely for use with Cypress hardware products. Any other use, reproduction, modification, translation, or compilation of the Software is prohibited.

TO THE EXTENT PERMITTED BY APPLICABLE LAW, CYPRESS MAKES NO WARRANTY OF ANY KIND, EXPRESS OR IMPLIED, WITH REGARD TO THIS DOCUMENT OR ANY SOFTWARE OR ACCOMPANYING HARDWARE, INCLUDING, BUT NOT LIMITED TO, THE IMPLIED WARRANTIES OF MERCHANTABILITY AND FITNESS FOR A PARTICULAR PURPOSE. No computing device can be absolutely secure. Therefore, despite security measures implemented in Cypress hardware or software products, Cypress does not assume any liability arising out of any security breach, such as unauthorized access to or use of a Cypress product. In addition, the products described in these materials may contain design defects or errors known as errata which may cause the product to deviate from published specifications. To the extent permitted by applicable law, Cypress reserves the right to make changes to this document without further notice. Cypress does not assume any liability arising out of the application or use of any product or circuit described in this document. Any information provided in this document, including any sample design information or programming code, is provided only for reference purposes. It is the responsibility of the user of this document to properly design, program, and test the functionality and safety of any application made of this information and any resulting product. Cypress products are not designed, intended, or authorized for use as critical components in systems designed or intended for the operation of weapons, weapons systems, nuclear installations, life-support devices or systems, other medical devices or systems (including resuscitation equipment and surgical implants), pollution control or hazardous substances management, or other uses where the failure of the device or system could cause personal injury, death, or property damage ("Unintended Uses"). A critical component is any component of a device or system whose failure to perform can be reasonably expected to cause the failure of the device or system, or to affect its safety or effectiveness. Cypress is not liable, in whole or in part, and you shall and hereby do release Cypress from any claim, damage, or other liability arising from or related to all Unintended Uses of Cypress products. You shall indemnify and hold Cypress harmless from and against all claims, costs, damages, and other liabilities, including claims for personal injury or death, arising from or related to any Unintended Uses of Cypress products.

Cypress, the Cypress logo, Spansion, the Spansion logo, and combinations thereof, WICED, PSoC, CapSense, EZ-USB, F-RAM, and Traveo are trademarks or registered trademarks of Cypress in the United States and other countries. For a more complete list of Cypress trademarks, visit cypress.com. Other names and brands may be claimed as property of their respective owners.