

XDPE152C4D Digital Multi-phase Controller

12-phase Dual Loop Voltage Regulator

Features

- Digital controller assisted with high performance analog front ends with a fully programmable ARM® Cortex™ –M0 Processor
- Compliant with Intel™ VR13, VR13HC, and VR14 Server VR Vendor PWM Enabling Specification Rev 1.88 (October 2021)
- Compliant with Intel™ SVID Rev 1.94 (April 2021)
- Compliant with PMBus Rev 1.3.1 (March 2015) serial interface
 - Query voltage, current, temperature faults
 - Fault Response
 - Maximum supported bus speed 1 MHz
 - Support 1.8/3.3 V operation
- Output voltage regulation range
 - 0.25 V to 1.52 V (5 mV/step)
 - 0.5 V to 3.04 V (10 mV/step)
- Digitally controlled phasing for full flexibility in both loop configuration and phase firing order
- Digital current emulation for TLVR inductor support
- Configurable autonomous phase add/drop
- Automatic phase detection at start-up
- Supports start-up into pre-bias voltage
- Integrated power stage current sense
- Differential output voltage sense
- Fast current balancing with current-mode control
- Digitally programmable PID (Proportional, Integral, Differential) loop compensation
- Digitally programmable loadline slope
- Digital temperature compensation
- Direct input (+12 V) voltage and current sense
- Extensive fault detection and protection capability
 - IUVP, OUVF & OOVF (fixed and tracking)
 - OCP instantaneous (total current)
 - Multiple OTP thresholds
 - Peak phase current pulse limiting
 - Negative current limit protection
 - TLVR secondary Open/Short detection
- Internal non-volatile memory (NVM) to store multiple custom configurations
- RoHS compliant and Halogen free 48-lead QFN plastic package

Final Datasheet

Potential applications

Potential applications

- Vcore power regulation for Intel™ VR13, VR13HC, VR14 based Microprocessors
 - Servers
 - Workstations
 - High-end desktops
- High Current ASIC, PMBus POLs

Product validation

Qualified for industrial applications according to the relevant tests of JEDEC47/20/22/78

Description

The XDPE152C4 digital dual loop 12 phase controller provides power for Intel™ VR13, VR13HC, VR14 server, workstation, and high-end desktop applications. Core voltage is provided by a multi-phase buck converter with up to 12 synchronous-rectified channels in parallel while a second loop provides voltage for the I/O. The XDPE152C4 phase configuration is flexible in how the phases are allocated to the 2 loops. Any phase can be assigned to either loop and the phase firing order is fully programmable to offer the ultimate in phase configuration flexibility. Typically, configurations of 12+0, 11+1, 10+2, 8+4 or 6+6 phases are supported.

Command and monitoring functions are controlled through the PMBus and SVID interfaces which supports dynamic voltage identification with 5 mV/step or 10 mV/step in Intel mode, output range up to 3.04 V, offset and trim resolution of 625 uV and accuracy better than 0.5%.

The XDPE152C4 controller utilizes digital technology to implement all control functions, providing the ultimate system solution in terms of flexibility and stability. Advanced control loop features, such as current mode control, variable frequency operation, Active Transient Response (ATR/FATR), fast DVID response, automatic phase shedding and Pulse Frequency Modulation (PFM) enable optimal response to a highly dynamic load with fast di/dt load transients across a wide range of load current.

The XDPE152C4 controller supports multi-vendor pin compatible integrated power stages with trivalent PWM interfaces, fast response, integrated current sense, integrated temperature sense, and advanced fault detection capability, interface and signaling.

In addition to supporting power stage fault protection features, the XDPE152C4 controller also includes a set of sophisticated over-voltage, under-voltage, over-temperature, over-current, and phase fault protections. These attributes provide a complete and advanced protection feature set for microprocessor and power systems.

Infineon strongly recommends pairing Infineon's power stages with our Digital XDP™ family of controllers to ensure correct interoperability. Interoperability when pairing with other vendor power stages/ discrete power components cannot be guaranteed by Infineon and requires thorough evaluation and characterization by the power stage/ discrete power component vendor.

Table 1 Part number and package summary

Part Number	Package
XDPE152C4D	48-lead 6 mm x 6 mm QFN PG-VQFN-48

Table of contents

Features	1
Potential applications	2
Product validation	2
Description	2
Table of contents	3
1 Ordering information	4
2 Package marking	5
3 Environmental qualifications	6

Ordering information

1 Ordering information

Table 2 Ordering information

Sales Part Number	Package Type	Standard Pack Form and Quantity		Orderable Part Number
XDPE152C4D-0000	QFN 6 mm x 6 mm	Tape and Reel	4000	XDPE152C4D0000XTMA1 Note 1
				XDPE152C4DxyzzXTMA1 Note 2

Note:

1. Standard Part Number with default configuration
2. Customer Specific Part Number, where *x* = Firmware ID, and *yz* = Custom Config File ID (Codes assigned by Product Marketing).

Sample Programming

The customer can program the parts to their specific system requirements using software/hardware available from Infineon or through other controller programming 3rd Parties (contact Infineon for recommendations). Infineon Field Application Engineers are available to assist with system and configuration file optimization and programming of the controllers. Alternatively, samples can be ordered with a customer specific configuration pre-programmed at the factory, but lead times for these types of samples are significantly longer than for standard default configuration samples. The generic part numbering format is shown below:

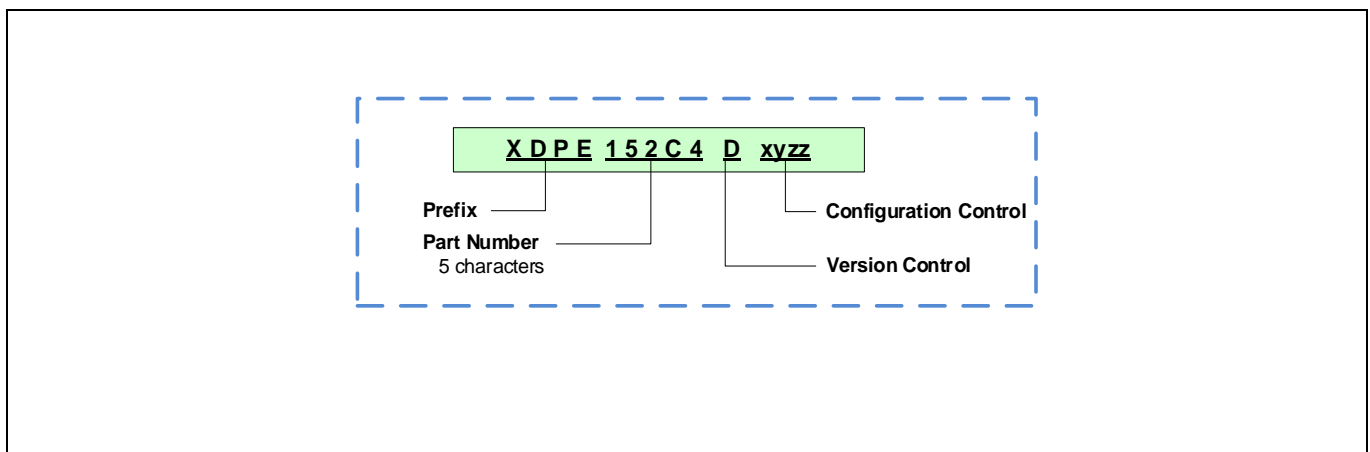

Figure 1 Part number decoding

Package marking

2 Package marking

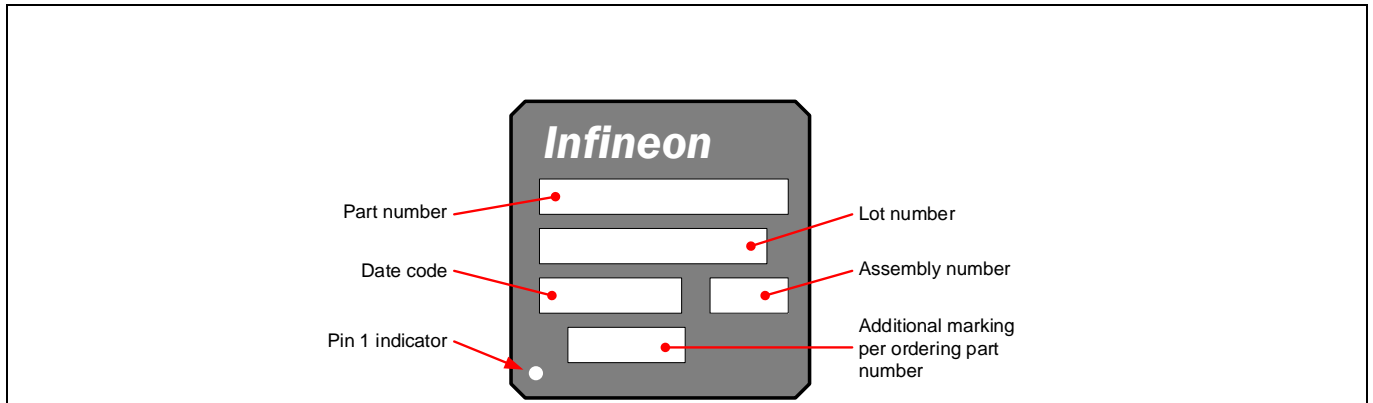

Figure 2 Package marking

3 Environmental qualifications

Table 3

Qualification Level		Industrial	
Moisture Sensitivity		QFN Package	MSL1
ESD	Human Body Model	JESD22-A114-F, Class 2	
	Charged Device Model	JESD22-C101-F, Class C3	
	Latch-up	JESD78D Class 2	
RoHS Compliant		Yes	

Revision History

XDPE152C4D short

Revision 2024-10-01, Rev. 1.0

Previous Revision

Revision	Date	Subjects (major changes since last revision)
1.0	2024-10-01	Release of final

Trademarks

All referenced product or service names and trademarks are the property of their respective owners.

Disclaimer

We Listen to Your Comments Any information within this document that you feel is wrong, unclear or missing at all? Your feedback will help us to continuously improve the quality of this document. Please send your proposal (including a reference to this document) to: erratum@infineon.com

Published by Infineon Technologies AG

81726 München, Germany

© 2024 Infineon Technologies AG

All Rights Reserved.

Legal Disclaimer The information given in this document shall in no event be regarded as a guarantee of conditions or characteristics ("Beschaffenheitsgarantie").

With respect to any examples, hints or any typical values stated herein and/or any information regarding the application of the product, Infineon Technologies hereby disclaims any and all warranties and liabilities of any kind, including without limitation warranties of non-infringement of intellectual property rights of any third party.

In addition, any information given in this document is subject to customer's compliance with its obligations stated in this document and any applicable legal requirements, norms and standards concerning customer's products and any use of the product of Infineon Technologies in customer's applications. The data contained in this document is exclusively intended for technically trained staff. It is the responsibility of customer's technical departments to evaluate the suitability of the product for the intended application and the completeness of the product information given in this document with respect to such application.

Information For further information on technology, delivery terms and conditions and prices please contact your nearest Infineon Technologies Office (www.infineon.com).

Warnings Due to technical requirements, components may contain dangerous substances. For information on the types in question, please contact the nearest Infineon Technologies Office. The Infineon Technologies component described in this Data Sheet may be used in life-support devices or systems and/or automotive, aviation and aerospace applications or systems only with the express written approval of Infineon Technologies, if a failure of such components can reasonably be expected to cause the failure of that life-support, automotive, aviation and aerospace device or system or to affect the safety or effectiveness of that device or system. Life support devices or systems are intended to be implanted in the human body or to support and/or maintain and sustain and/or protect human life. If they fail, it is reasonable to assume that the health of the user or other persons may be endangered.