

XDPE1A2G5B Digital Multi-phase Controller

16-phase Dual Loop Voltage Regulator

Features

- Digital controller assisted with high performance analog front ends with a fully programmable ARM® Cortex™ –M0 Processor
- PMBus compliant with rev 1.3.1 (March 2015) with AVSBus serial interface
 - Output voltage control
 - Query voltage, current, temperature faults
 - Fault Response
 - Maximum supported bus speed 1 MHz
 - Supports 1.8/3.3 V operation
- AVSBus
 - Supports 1.2V/1.8V operation
 - Supports clock frequencies up to 25MHz
- Output voltage regulation range
 - 0.05 V to 3.1 V (1 mV/step)
- Digitally controlled phasing for full flexibility in both loop configuration and phase firing order
- Configurable autonomous phase add/drop
- Automatic phase detection at start-up
- Supports start-up into pre-bias voltage
- Integrated power stage current sense
- Differential output voltage sense
- Fast current balancing with current-mode control
- Digitally programmable PID (Proportional, Integral, Differential) loop compensation
- Digitally programmable load line slope and offset
- Digital temperature compensation
- Extensive fault detection and protection capability
 - IUVF, OUVF & OOVF (fixed and tracking)
 - OCP instantaneous & averaged (total current)
 - Multiple OTP thresholds
 - Peak phase current pulse limiting
 - Negative current limit protection
- Internal non-volatile memory (NVM) to store multiple custom configurations
- RoHS compliant and Halogen free 56-lead QFN plastic package

XDPE1A2G5B view

XDPE1A2G5B Digital Multi-phase Controller

16-phase Dual Loop Voltage Regulator



Potential applications

Potential applications

- CORE power regulator for AI based Microprocessors
 - Telecom applications
 - ASIC POWER

Product validation

Qualified for industrial applications according to the relevant tests of JEDEC47/20/22

Description

The XDPE1A2G5B digital dual loop 16 phase controller provides power for AI servers, workstation, and telecom applications that use AVSBUS. Voltage on either the first loop or the second loop can be provided by a multi-phase buck converter with up to 16 synchronous-rectified channels. Typical configurations of 16+0, 15+1, and up to 8+8 are supported.

Command and monitoring functions are controlled through the PMBus and AVS interfaces which supports dynamic voltage identification with 1 mV/step, output range up to 3.1 V, offset and trim resolution of 625 μ V and accuracy better than 0.5%.

The XDPE1A2G5B controller utilizes digital technology to implement all control functions, providing the ultimate system solution in terms of flexibility and stability. Advanced control loop features, such as current mode control, variable frequency operation, Active Transient Response (ATR/FATR), fast DVID response, automatic phase shedding and Pulse Frequency Modulation (PFM) enable optimal response to a highly dynamic load with fast di/dt load transients across a wide range of load current.

The XDPE1A2G5B controller supports multi-vendor pin compatible integrated power stages with trivalent PWM interfaces, fast response, integrated current sense, integrated temperature sense, and advanced fault detection capability, interface and signaling.

In addition to supporting power stage fault protection features, the XDPE1A2G5B controller also includes a set of sophisticated over-voltage, under-voltage, over-temperature, over-current, and phase fault protections. These attributes provide a complete and advanced protection feature set for microprocessor and power systems.

Infineon strongly recommends pairing Infineon's power stages with our Digital XDP™ family of controllers to ensure correct interoperability. Interoperability when pairing with other vendor power stages/ discrete power components cannot be guaranteed by Infineon and requires thorough evaluation and characterization by the power stage/ discrete power component vendor.

Table 1 Part number and package summary

Part Number	Package
XDPE1A2G5B	56-lead 7 mm x 7 mm QFN PG-VQFN-56

Table of contents

Features	1
Potential applications	2
Product validation	2
Description	2
Table of contents	3
1 Ordering information	4
2 Package marking	5
3 Environmental qualifications	6

Ordering information

1 Ordering information

Table 2 Ordering information

Base Part Number	Package Type	Standard Pack Form and Quantity		Orderable Part Number
XDPE1A2G5B	QFN 7 mm x 7 mm	Tape and Reel	3000	XDPE1A2G5B0000XUMA1 Note 1
				XDPE1A2G5BxyzzXUMA1 Note 2

Note:

1. Standard part number with default configuration
2. Customer Specific Configuration File, where x = Firmware ID and yzz = Custom Configuration File ID (Codes assigned by Product Marketing).

Sample Programming

The customer can program the parts to their specific system requirements using software/hardware available from Infineon or through other controller programming facilities (contact Infineon for recommendations). Infineon Field Application Engineers are available to assist with system and configuration file optimization and programming of the controllers. Alternatively, samples can be ordered with a customer specific custom configuration pre-programmed at the factory, but lead times for these types of samples are significantly longer than for non-configured samples. The generic part numbering format is shown below:

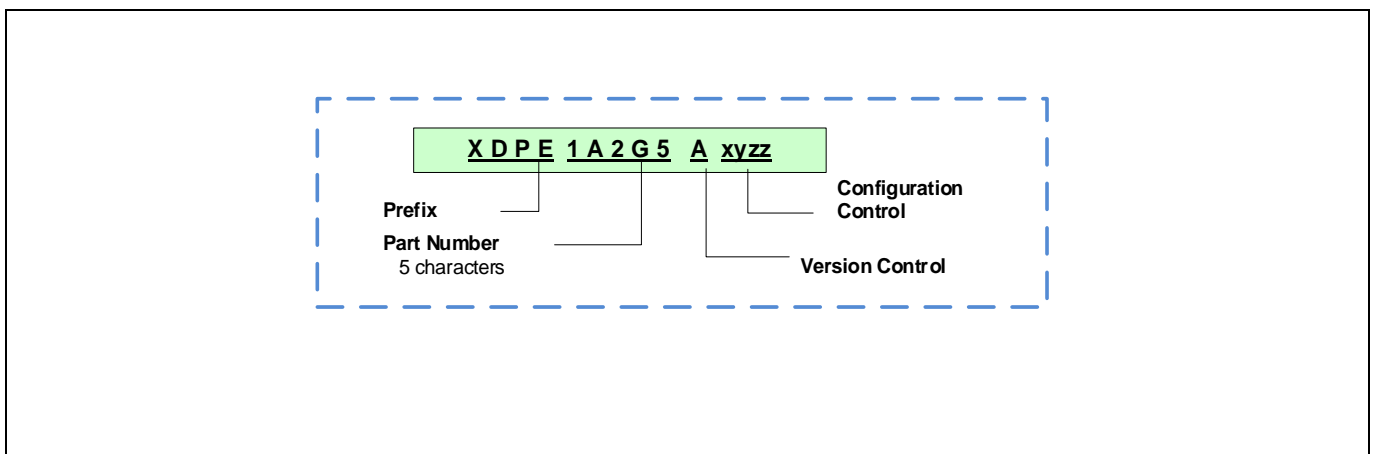

Figure 1 Part number decoding

Package marking

2 Package marking

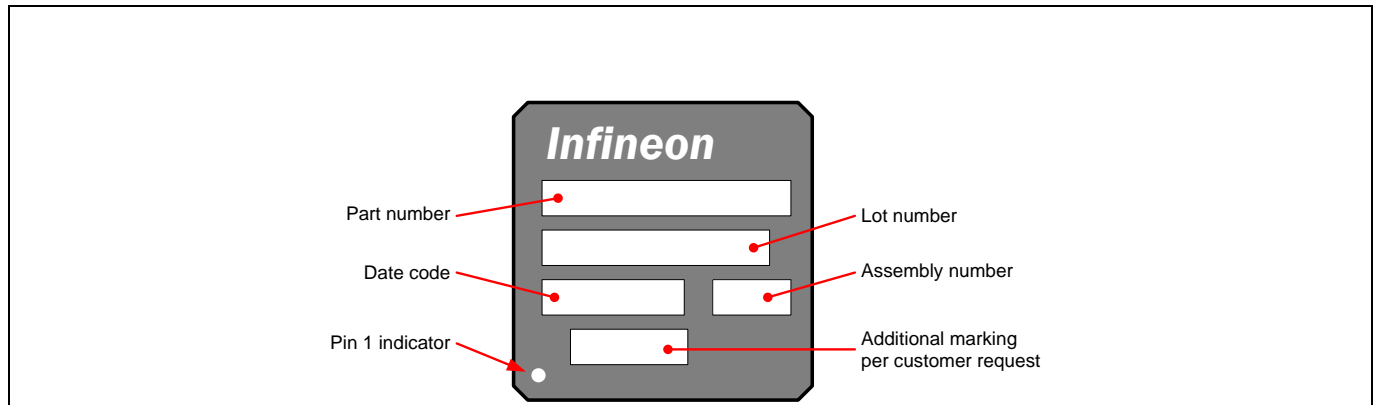

Figure 2 Package marking

3 Environmental qualifications

Table 3

Qualification Level		Industrial	
Moisture Sensitivity		QFN Package	MSL3
ESD	Human Body Model	JS-001, Class 2	
	Charged Device Model	JS-002, Class C3	
	Latch-up	JESD78, Class 2	
RoHS Compliant		Yes	

Revision History

XDPE1A2G5B-short

Revision 2024-04-09, Rev. 2.3

Previous Revision

Revision	Date	Subjects (major changes since last revision)
2.2	2024-02-29	Release of short form data sheet
2.3	2024-04-09	Remove 'Restricted' from the header

Trademarks

All referenced product or service names and trademarks are the property of their respective owners.

Disclaimer

We Listen to Your Comments Any information within this document that you feel is wrong, unclear or missing at all? Your feedback will help us to continuously improve the quality of this document. Please send your proposal (including a reference to this document) to: erratum@infineon.com

Published by Infineon Technologies AG

81726 München, Germany

© 2024 Infineon Technologies AG

All Rights Reserved.

Legal Disclaimer The information given in this document shall in no event be regarded as a guarantee of conditions or characteristics ("Beschaffungsgarantie").

With respect to any examples, hints or any typical values stated herein and/or any information regarding the application of the product, Infineon Technologies hereby disclaims any and all warranties and liabilities of any kind, including without limitation warranties of non-infringement of intellectual property rights of any third party.

In addition, any information given in this document is subject to customer's compliance with its obligations stated in this document and any applicable legal requirements, norms and standards concerning customer's products and any use of the product of Infineon Technologies in customer's applications. The data contained in this document is exclusively intended for technically trained staff. It is the responsibility of customer's technical departments to evaluate the suitability of the product for the intended application and the completeness of the product information given in this document with respect to such application.

Information For further information on technology, delivery terms and conditions and prices please contact your nearest Infineon Technologies Office (www.infineon.com).

Warnings Due to technical requirements, components may contain dangerous substances. For information on the types in question, please contact the nearest Infineon Technologies Office. The Infineon Technologies component described in this Data Sheet may be used in life-support devices or systems and/or automotive, aviation and aerospace applications or systems only with the express written approval of Infineon Technologies, if a failure of such components can reasonably be expected to cause the failure of that life-support, automotive, aviation and aerospace device or system or to affect the safety or effectiveness of that device or system. Life support devices or systems are intended to be implanted in the human body or to support and/or maintain and sustain and/or protect human life. If they fail, it is reasonable to assume that the health of the user or other persons may be endangered.